

FIRE DAMPER UPGRADE SYSTEMS



Maxilite is a lightweight high-performance fire rated board which is highly adaptable to provide tested solutions in challenging scenarios. Stable under high temperatures whilst being crack free, Maxilite is perfectly suited for upgrading existing fire dampers.



KEY FEATURES

- Lightweight
- High resistance to heat
- Tested to AS1530.4-2014 and AS4072.1 compliant
- Various methods of installation
- Retrofit application
- Easy to cut and handle
- Environmentally friendly



APPLICATIONS

- Upgrading non-compliant fire dampers
- Closing down gaps and holes around fire dampers
- Suitable for mechanical & intumescent dampers
- Walls and floors



TRADES



Table of Contents



	Page	
Overview	1	
What is Maxilite and its Applications	3	
Product Specifications	4	
FRL Details	5	
FRL Tables- Walls and Floors Applications	6	
Installation Manual	Section A- MFDU-1	7
	Section A- MFDU-2	8
	Section A- MFDU-3	9
	Section A- MFDU-4	10
	Section A- MFDU-5	11
	Section A- MFDU-6	12
	Section A- MFDU-7	13
	Section B- WMD-1	14
	Section B- WMD-2	15
	Section B- WMD-3	16
	Section B- WMD-4	17
	Section B- WMD-5	18
	Section B- WMD-6	19
	Section C- FMD-1	20
	Section C- FMD-2	21
	Section C- FMD-3	22
	Section C- FMD-4	23
	Section C- FMD-5	24
	Section C- FMD-6	25
	Section C- FMD-7	26
Section D- Speedpanel and Damper Detail	27	
System Range- Related Products	28	
Fire Rated Air Transfer Grilles	29	
FAQs	30	

FyreBOARD MAXILITE

Fire Rated Board

What is MAXILITE

Often walls are finished short or left with oversized openings to allow for the installation of a fire damper. Maxilite Fire Damper Upgrade systems allow for the installation of a fire damper whilst simultaneously sealing the oversized penetration and maintaining the fire integrity of the wall as required by the National Construction Code (NCC).

Maxilite is a lightweight, high performance fire rated board. It is calcium-silicate based product, bonded together with non-organic binders, no asbestos, and low volatile organic compounds (VOC's). It is a versatile product, providing numerous potential solutions in even the most difficult situations.

Maxilite boards are able to withstand high temperatures while remaining stable and crack free, making it an ideal product for fire protection. Particularly suited to closing-down oversize penetrations, Maxilite has been tested to the current AS1530.4 – 2014 standard with many of our products, presenting various solutions to the industry.

Whilst this technical manual will focus on Maxilite Fire Damper Upgrade (MFDU) systems, Maxilite can also be used other applications including penetrations, bulkheads and steel protection.

Applications

- [FyreBOARD Maxilite Penetration Systems Technical Manual](#)
- [FyreBoard Maxilite Steel Protection Technical Manual](#)
- [FyreBOARD Maxilite Bulkhead Systems Technical Manual](#)

PRODUCT SPECIFICATIONS



Spec	Detail		
Thickness	30, 40 & 60mm		
Sheet size (half sheets available)	1520x1000mm (white) 2040x1220mm (blue)		
Density (avg, dry)	330Kg/m ³		
Board weight	30mm	1520x1000: 16Kg	2040x1220: 23Kg
	40mm	1520x1000: 22Kg	2040x1220: 30Kg
	60mm	1520x1000: 32Kg	2040x1220: 45Kg
Material	Calcium Silicate		
Combustible	Non-combustible (AS1530.1)		
Maximum service temp	1000 deg C		
Permeability to gasses	1.0 nPm		
Specific heat	0.84 KJ/(KgK)		
Thermal conductivity	0.09 W/(mK) at 200 deg C		
R-value	30mm	0.33m ² K/w	
	40mm	0.44m ² K/w	
	60mm	0.67m ² K/w	
Acoustic ratings	30mm: Rw30 (Rw+Ctr 28) 40mm: Rw31 (Rw+Ctr 28) 60mm: Rw33 (Rw+Ctr 30)		
Flexural strength	1.27MPa		
Asbestos content	0%		
Storage	Store in a cool, dry environment Transport on pallets to avoid breakage		
Handling	Cuts easily with hand tools or power saws. Ensure the board is supported appropriately whilst cutting to avoid breakage		

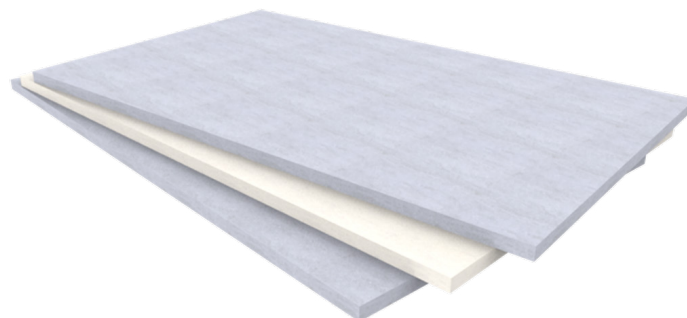

FRL DETAILS

FIRE RATING – HOW IS FIRE PERFORMANCE MEASURED?

An FRL (fire resistance level) is a handy way of summarising the performance of a building element. It consists of 3 numbers, all given in minutes:

FRL 120/120/120

(example)



Structural Adequacy

The ability of the building element to support the weight of adjacent building elements.

ie: a brick wall supporting a concrete floor slab above.



Integrity

The ability of an element to prevent the passage of flames and hot gasses.

ie: a plasterboard wall remaining intact and not allowing holes to form.

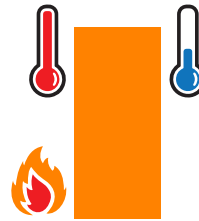

Insulation

The ability of an element to resist heat transfer from the exposed face to the unexposed face.

ie: a bundle of cables remaining below a set temperature limit on the unexposed side of the wall penetration system.

Integrity

The Maxilite system can achieve the integrity performance for up to 4 hours physically stopping the direct spread of fire. Although Maxilite has been tested for integrity up to 4 hours, it is limited to that of the damper/fire barrier.

Insulation (Temperature Rise)

Although Maxilite boards can achieve high insulation ratings by themselves, fire dampers generally are not capable of achieving any level of insulation rating. To address this, AS1668.1 does include insulation waivers for fire dampers in certain applications so an FRL of-/120/- can be acceptable. In certain instances where the waiver is not applicable, it is possible to wrap the duct with FyreWRAP for a distance of 2m to attain the insulation performance.

FRL Tables- FyreBOARD Damper Upgrade Systems

Walls and Floors Application

Substrate	Maximum approved size of Maxilite	FRL	Approved Dampers
Concrete/Masonry (wall/floor)	One sheet 60mm x 1500mm x 1000mm	Up to-/120/- (limited to that of the damper/fire barrier).	Any fire damper which has been independently tested and validated for use in a wall/ floor for 120 minutes integrity.
Hollow Block			
Plasterboard			
Shaft Wall			
Hebel			
Speedpanel			

Note: Fire Dampers by their nature are constructed with steel framing and therefore do not commonly achieve insulation ratings. To accommodate for this, AS1668.1 includes requirements for fire damper installations which can allow their insulation rating to be waived in certain conditions.

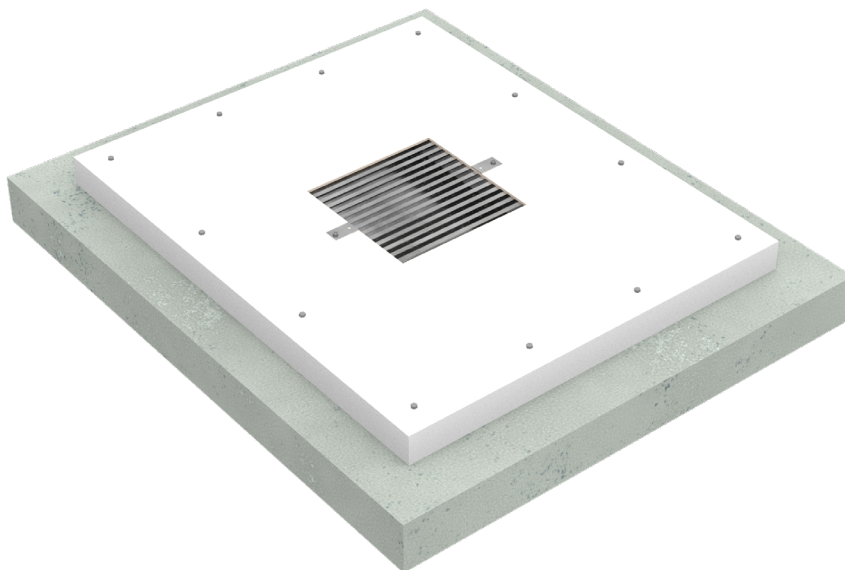

Installation Manual

Section A – MFDU - 1

This installation detail consists of Min. 40mm Maxilite strips secured around the perimeter of the damper, the slab soffit and and/or the perimeter of the wall opening. These strips are then faced with Min. 30mm Maxilite Board.

Key Details

- Damper sealed as per damper approval or with FyreFLEX
- All joints in Maxilite are sealed with FyreFLEX Sealant
- All screw fixings are of a length equal to 1.5 X Maxilite thickness.
- Fire damper is installed as per manufacturers specifications.
- Max. 200mm centres between 8g plasterboard screw centres into Maxilite
- Max. 300mm centres for M6 masonry anchors securing Maxilite to soffit/slab

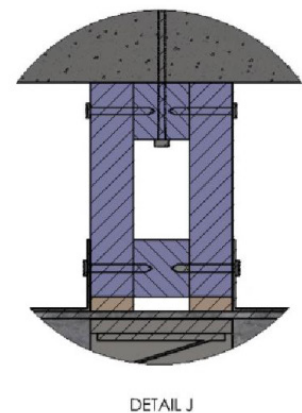
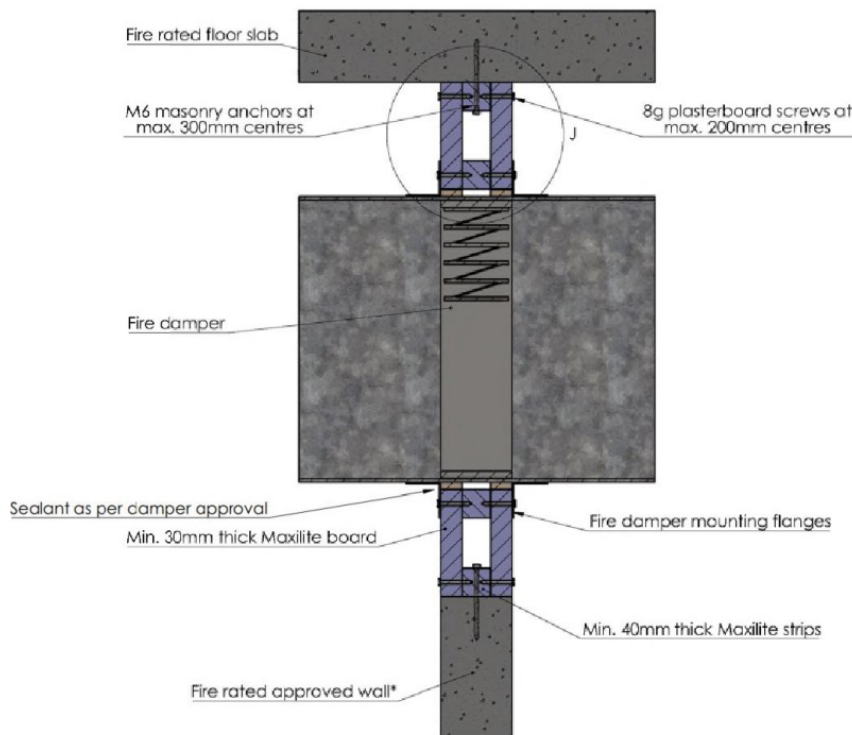

*	Approved wall systems
1	75mm AAC (Hebel/Walco)
2	Concrete - thickness as per AS3600
3	Masonry - thickness as per AS3700

Installation Manual

Section A – MFDU - 2

This installation detail consists of a steel square hollow section (SHS) clad with Min. 30mm Maxilite. This clad steel section is then fixed to a Maxilite strip which has been secured around the perimeter of the slab soffit and/or wall opening.

Key Details

- Damper sealed as per damper approval or with FyreFLEX
- All joins in Maxilite are sealed with FyreFLEX Sealant
- All screw fixings are of a length equal to 1.5 X Maxilite thickness.
- Fire damper is installed as per manufacturers specifications.
- Max. 200mm centres between 8g plasterboard screw centres into Maxilite
- Max. 300mm centres for M6 masonry anchors securing Maxilite to soffit/slab
- Min. 50x50mm SHS

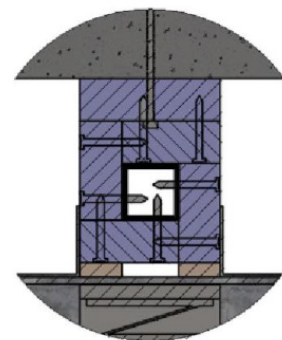
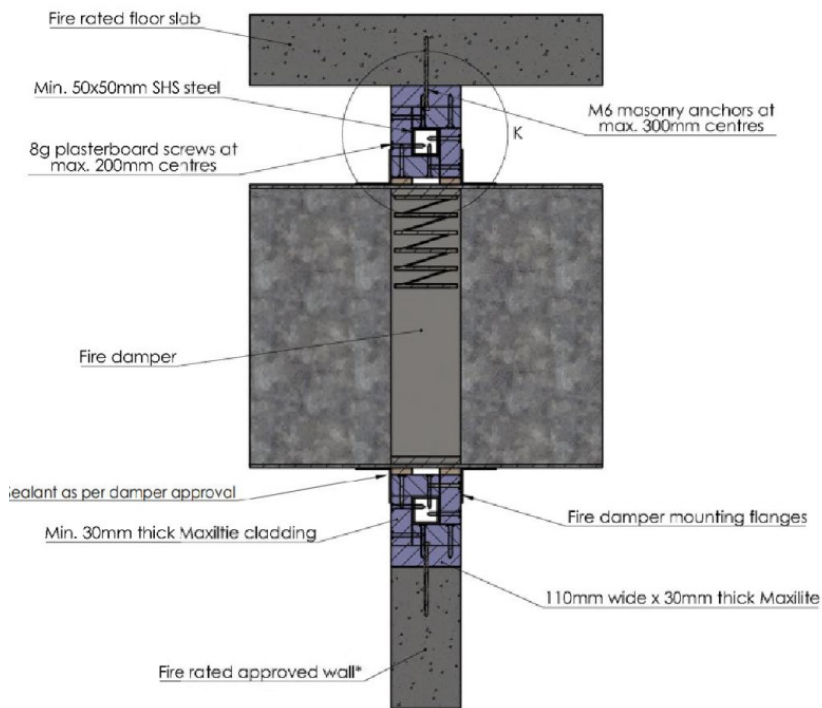

DETAIL K

*	Approved wall systems
1	75mm AAC (Hebel/Walsc)
2	Concrete - thickness as per AS3600
3	Masonry - thickness as per AS3700

Installation Manual

Section A – MFDU - 3

This installation detail consists of laminated strips of Maxilite Min. 20mm secured around the perimeter of the damper, the slab soffit and/or the perimeter of the wall opening.

Key Details

- Damper sealed as per damper approval or with FyreFLEX
- All joints in Maxilite are sealed with FyreFLEX Sealant
- All screw fixings are of a length equal to 1.5 X Maxilite thickness.
- Fire damper is installed as per manufacturers specifications.
- Max. 200mm centres 8g plasterboard screw centres into Maxilite
- Max. 300mm centres for M6 masonry anchors securing Maxilite to soffit/slab

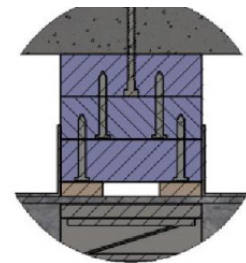
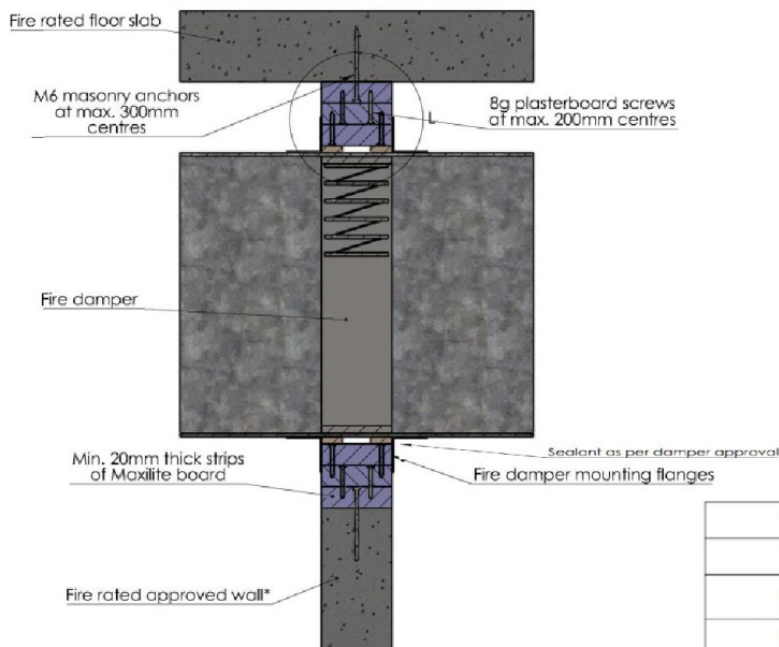

DETAIL L

*	Approved wall systems
1	75mm AAC (Hebel/Walsc)
2	Concrete - thickness as per AS3600
3	Masonry - thickness as per AS3700

Installation Manual

Section A – MFDU - 4

This installation detail consists of a steel angle secured centrally around the perimeter of the slab soffit and/or the wall opening. Min. 20mm Maxilite board is then laminated on each side of the angle, filling the opening around the damper.

Key Details

- Damper sealed as per damper approval or with FyreFLEX
- All joints in Maxilite are sealed with FyreFLEX Sealant
- All screw fixings are of a length equal to 1.5 X Maxilite thickness.
- Fire damper is installed as per manufacturers specifications.
- Max. 200mm centres between 8g plasterboard screw centres into Maxilite
- Max. 300mm centres for M6 masonry anchors securing Maxilite to soffit/slab
- Min. 30 x 30 x 0.9mm steel angle

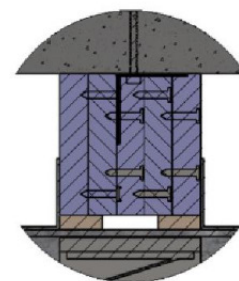
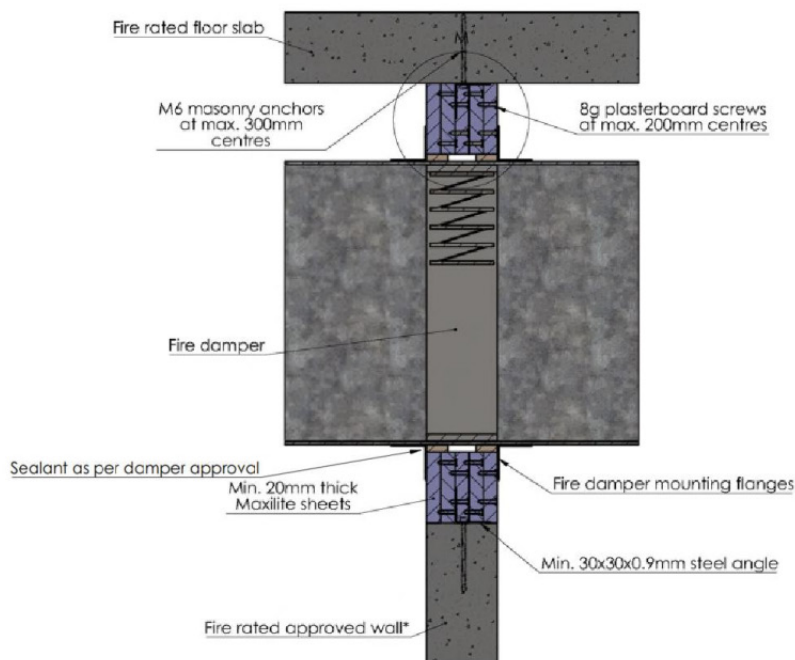

DETAIL M

*	Approved wall systems
1	75mm AAC (Hebel/Walco)
2	Concrete - thickness as per AS3600
3	Masonry - thickness as per AS3700

Installation Manual

Section A – MFDU - 5

This installation detail consists of laminated strips of Min. 20mm Maxilite secured around the perimeter of the damper, the slab soffit and and/or the perimeter of the wall opening. A Min. 30mm Maxilite board is then faced over these previously laminated Maxilite strips.

Key Details

- Damper sealed as per damper approval or with FyreFLEX
- All joints in Maxilite are sealed with FyreFLEX Sealant
- All screw fixings are of a length equal to 1.5 X Maxilite thickness.
- Fire damper is installed as per manufacturers specifications.
- Max. 200mm centres 8g plasterboard screw centres into Maxilite.
- Max. 300mm centres for M6 masonry anchors securing Maxilite to soffit/slab

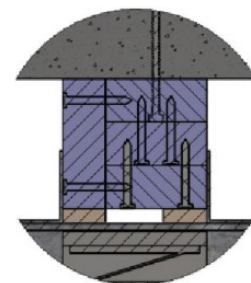
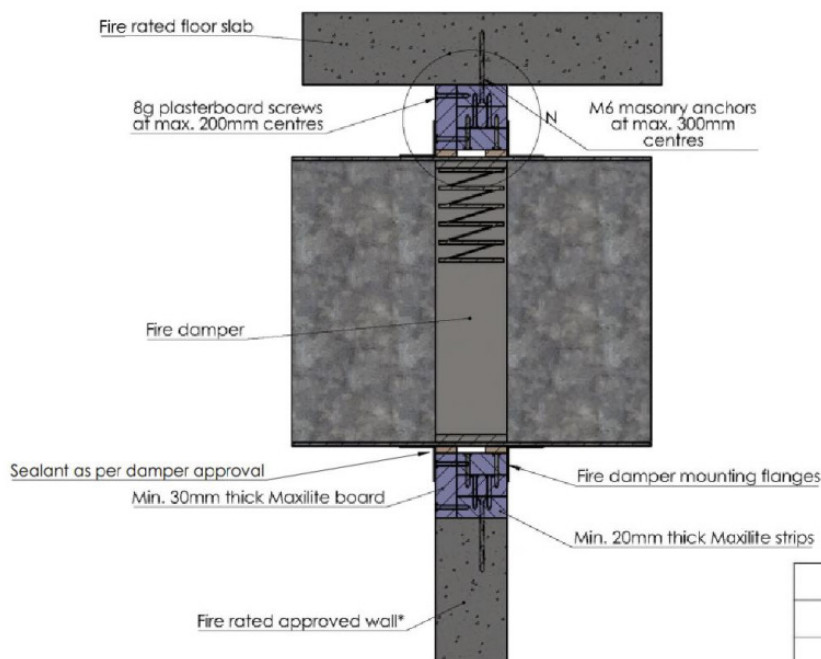

DETAIL N

*	Approved wall systems
1	75mm AAC (Hebel/Walsc)
2	Concrete - thickness as per AS3600
3	Masonry - thickness as per AS3700

Installation Manual

Section A – MFDU - 6

This installation detail consists of strips of Min. 40mm Maxilite secured around the perimeter of the duct and the slab soffit (if required). Min. 30mm Maxilite board is then fixed over the wall and the previously secured Maxilite strips.

Key Details

- Damper sealed as per damper approval or with FyreFLEX
- All joints in Maxilite are sealed with FyreFLEX Sealant
- All screw fixings are of a length equal to 1.5 X Maxilite thickness.
- Fire damper is installed as per manufacturers specifications.
- Maxilite board overlaps the wall opening by at least 100mm
- Max. 200mm centres 8g plasterboard screw centres into Maxilite
- Max. 300mm centres for M6 masonry anchors securing Maxilite to soffit/slab
- M6 threaded rod and support

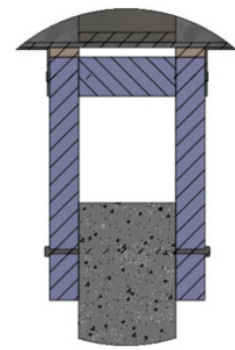
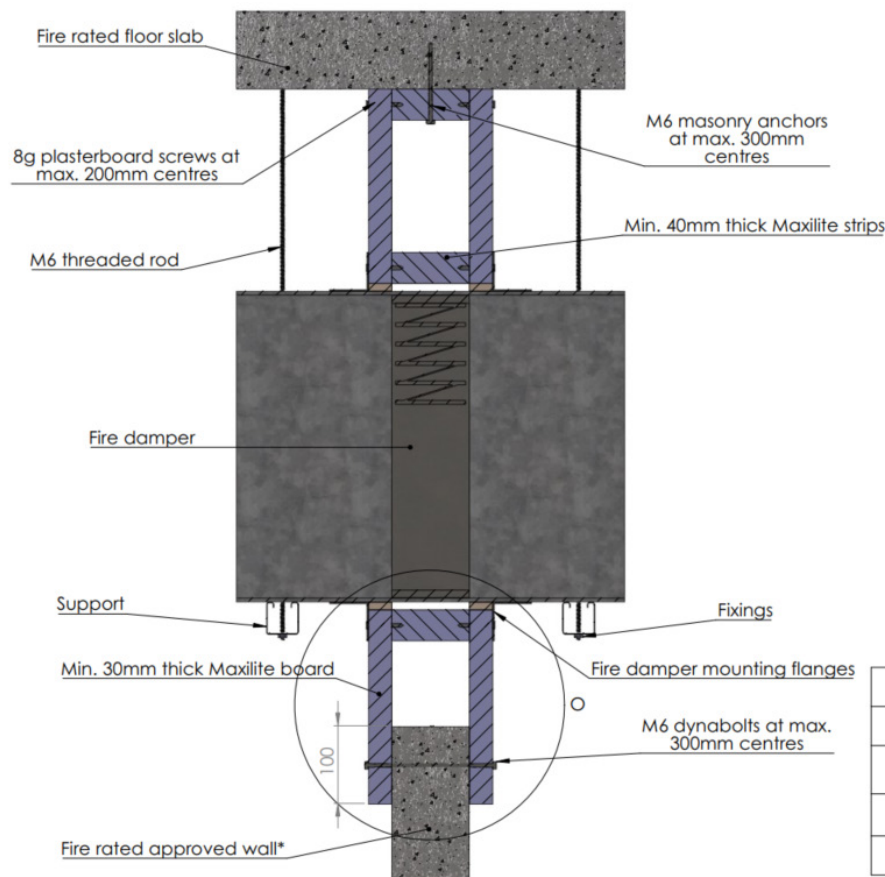

DETAIL O

*	Approved wall systems
1	75mm AAC (Hebel/Walsc)
2	78mm Speedpanel
3	Concrete - thickness as per AS3600
4	Masonry - thickness as per AS3700

Installation Manual

Section A – MFDU - 7

This installation detail consists of a panel of Maxilite, with an intumescent damper, fixed to the face of the wall, over the wall opening.

Key Details

- Damper sealed as per damper approval or with FyreFLEX
- All joints in Maxilite are sealed with FyreFLEX Sealant
- Maxilite board overlaps the wall opening by at least 100mm
- Fire damper is installed as per manufacturers specifications.
- The maximum damper size is 800 x 800mm
- The maximum Maxilite panel size is 1200 x 1200mm OR 1500 x 1000mm
- Max. 300mm centres for M6 masonry anchors securing Maxilite to wall

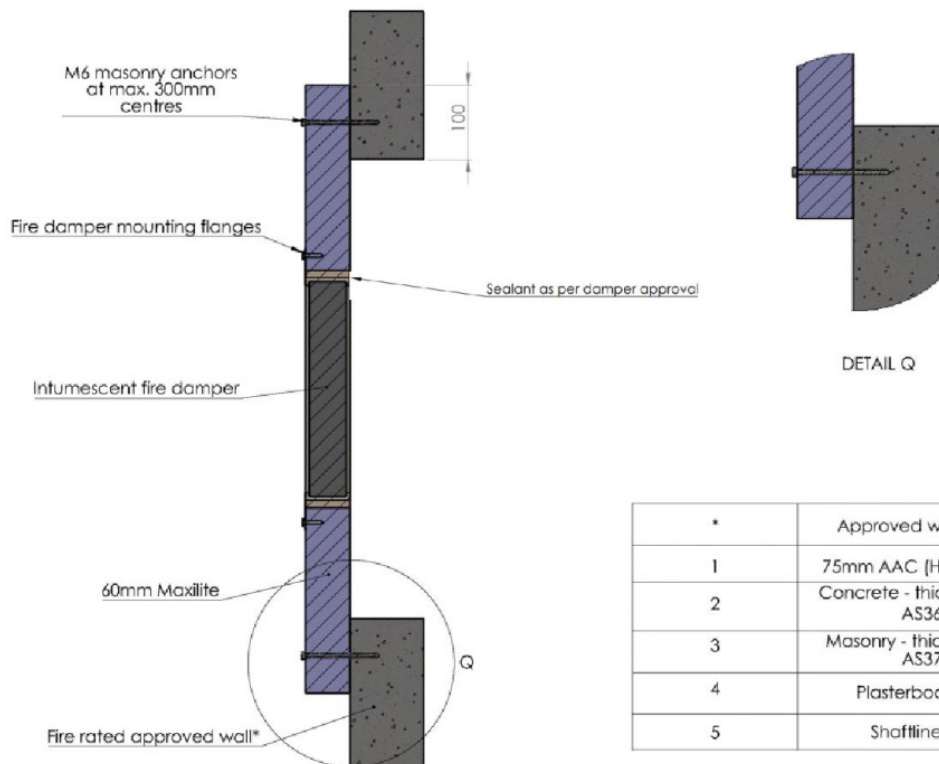

Installation Manual

Section B – WMD - 1

This installation detail involves lining the plasterboard wall with 2x layers of Min. 30mm Maxilite strips equal to the width of the wall plasterboard wall system.

Key Details

- Damper sealed as per damper approval or with FyreFLEX
- All joints in Maxilite are sealed with FyreFLEX Sealant.
- All screw fixings are of a length equal to 2 X plasterboard thickness.
- Fire damper is approved for use in plasterboard walls and installed as per manufacturers specifications
- Max. 200mm centres 8g plasterboard screw centres into Maxilite

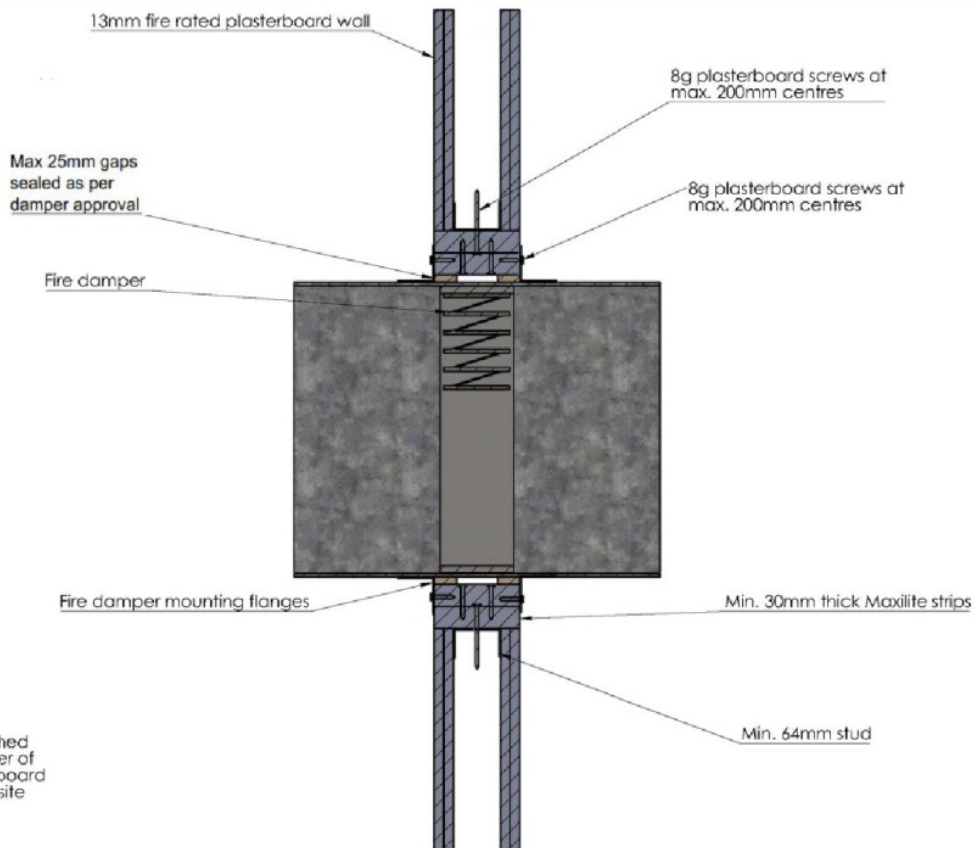

Installation Manual

Section B – WMD - 2

This installation detail involves trimming all four sides of the wall opening with Maxilite strips of equal width to the wall studs.

Key Details

- Damper sealed as per damper approval or with FyreFLEX
- All joints in Maxilite are sealed with FyreFLEX Sealant.
- All screw fixings are of a length equal to 2 X plasterboard thickness.
- Fire damper is approved for use in plasterboard walls and installed as per manufacturers specifications
- Max. 200mm centres 8g plasterboard screw centres into Maxilite

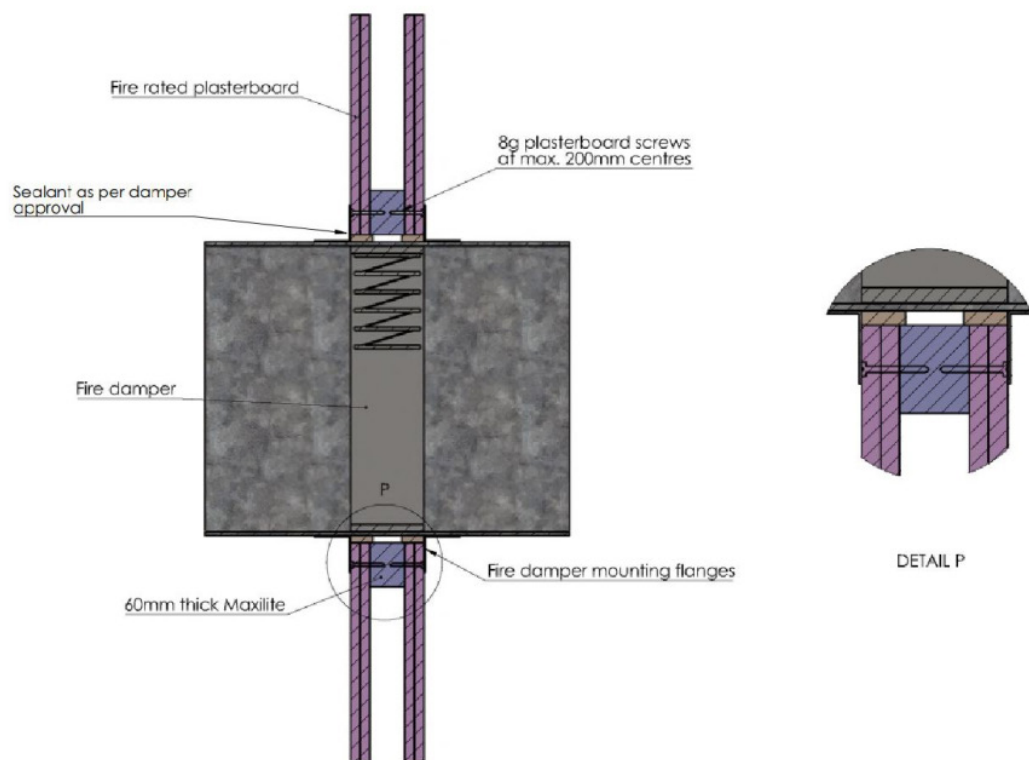

Installation Manual

Section B – WMD - 3

This installation detail involves lining the shaft wall with 2x layers of Min. 30mm Maxilite strips equal to the width of the wall plasterboard wall system.

Key Details

- Damper sealed as per damper approval or with FyreFLEX
- All joints in Maxilite are sealed with FyreFLEX Sealant.
- All screw fixings are of a length equal to 2 X plasterboard thickness.
- Fire damper is approved for use in plasterboard walls and installed as per manufacturers specifications
- Max. 200mm centres 8g plasterboard screw centres into Maxilite

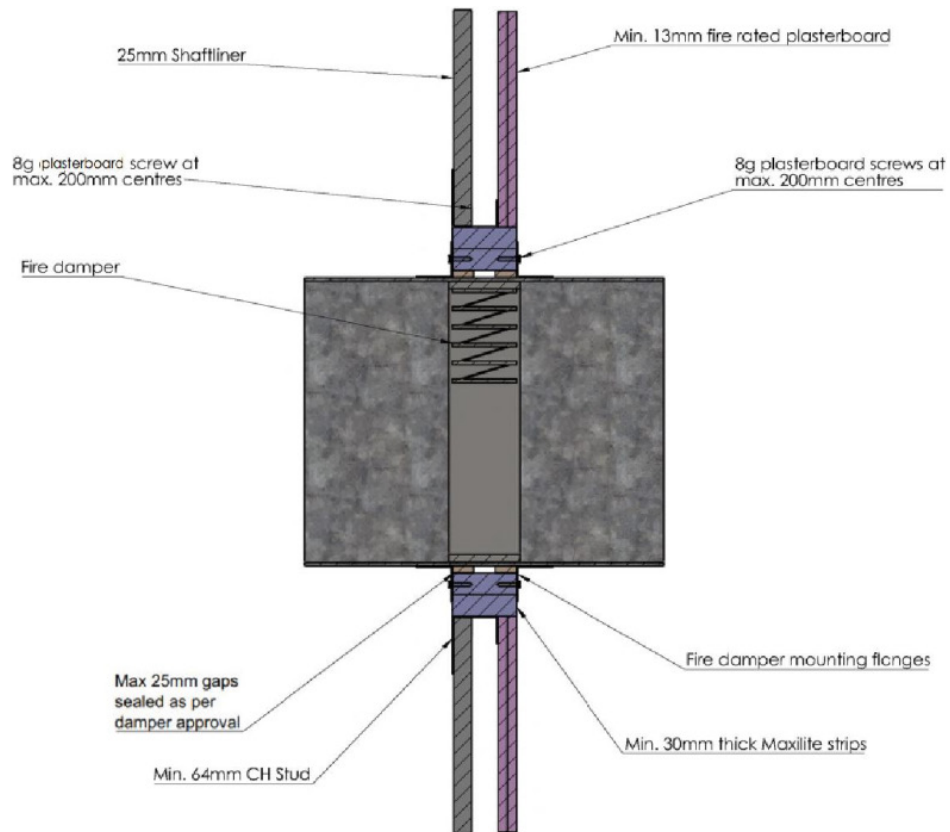

Installation Manual

Section B – WMD - 4

This installation detail involves trimming all four sides of the wall opening with Maxilite strips of equal width to the wall studs. Additionally, it is required to line the shaft wall with 2x layers of Min. 30mm Maxilite strips equal to the width of the wall plasterboard wall system.

Key Details

- Damper sealed as per damper approval or with FyreFLEX
- All joins in Maxilite are sealed with FyreFLEX Sealant
- All screw fixings are of a length equal to 2 X plasterboard thickness.
- Fire damper is approved for use in plasterboard walls and installed as per manufacturers specifications
- Max. 200mm centres 8g plasterboard screw centres into Maxilite

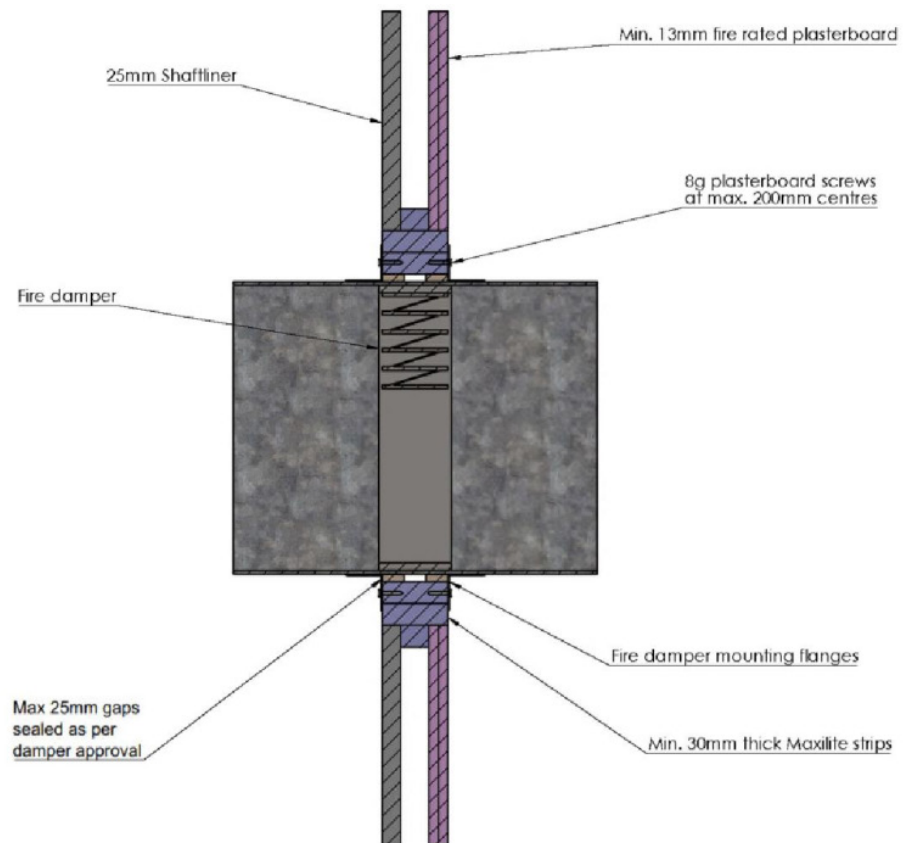

Installation Manual

Section B – WMD - 5

This installation detail consists of a panel of Maxilite, with an intumescent damper, fixed to the face of the wall, over the wall opening.

Key Details

- Damper sealed as per damper approval or with FyreFLEX
- All joints in Maxilite are sealed with FyreFLEX Sealant
- Maxilite board overlaps the wall opening by at least 100mm
- Fire damper is installed as per manufacturers specifications.
- The maximum damper size is 800 x 800mm
- The maximum Maxilite panel size is 1200 x 1200mm OR 1500 x 1000mm
- Max. 200mm centres for 8g screws securing Maxilite to wall

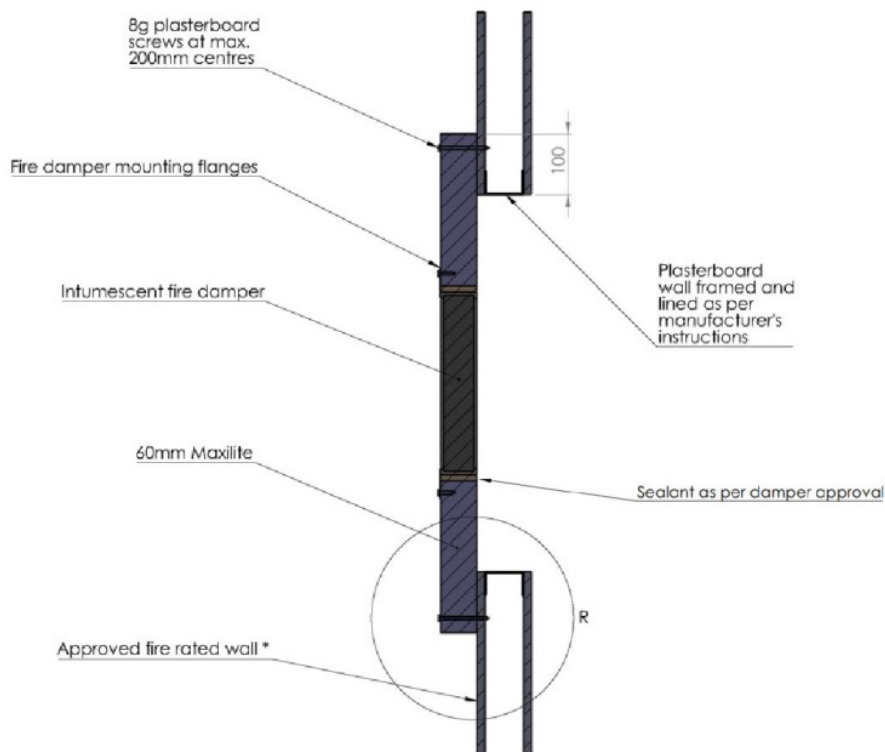

*	Approved wall systems
1	Min. 1 layer Plasterboard walls
2	Shaftliner walls

Installation Manual

Section B – WMD - 6

This installation detail involves lining the Trafalgar Corex shaft wall with 1-3 layers of Min. 30mm Maxilite strips equal to the width of the wall Trafalgar Corex shaft wall system.

Key Details

- Damper sealed as per damper approval or with FyreFLEX
- All joints in Maxilite are sealed with FyreFLEX Sealant.
- All screw fixings are of a length equal to 2 X plasterboard thickness.
- Fire damper is approved for use in plasterboard walls and installed as per manufacturers specifications
- Max. 200mm centres 8g plasterboard screw centres into Maxilite

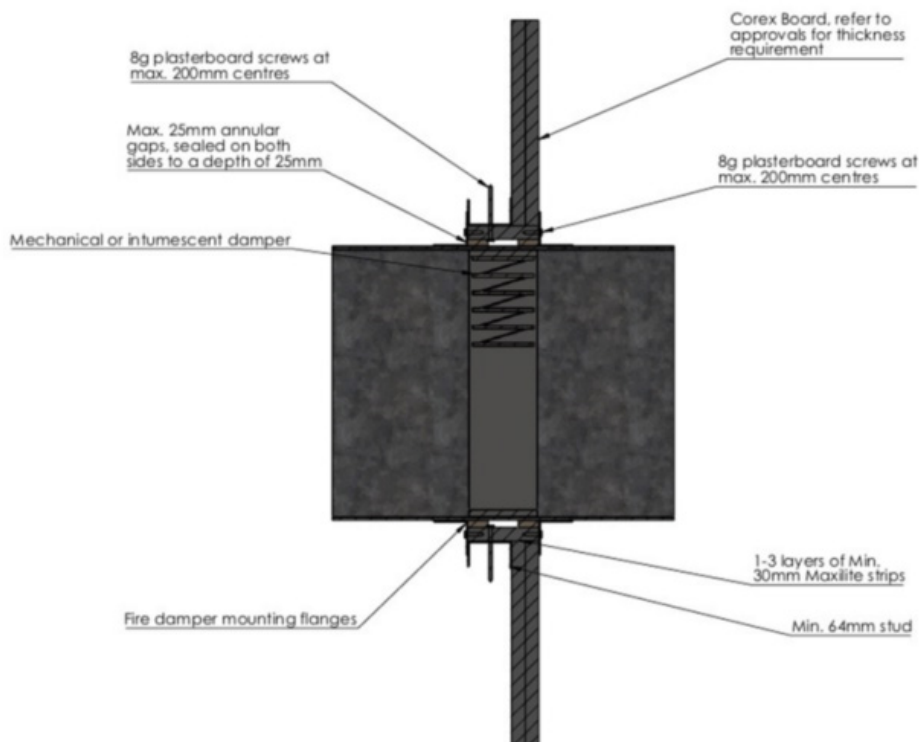

Installation Manual

Section C – FMD - 1

This installation detail consists of two layers min. 30mm Maxilite strips. The first layer is secured to the concrete slab using M6 masonry anchors at max. 300mm centres. The second layer is fixed to the first later using 8g screws at max. 200mm centres.

Key Details

- Damper sealed as per damper approval or with FyreFLEX
- All joints in Maxilite are sealed with FyreFLEX Sealant
- Max. 300mm centres for M6 masonry anchors securing Maxilite to slab
- Max. 200mm centres 8g plasterboard screw centres securing second Maxilite strip into the first.
- Fire damper is approved for use in slabs and installed as per manufacturers specifications

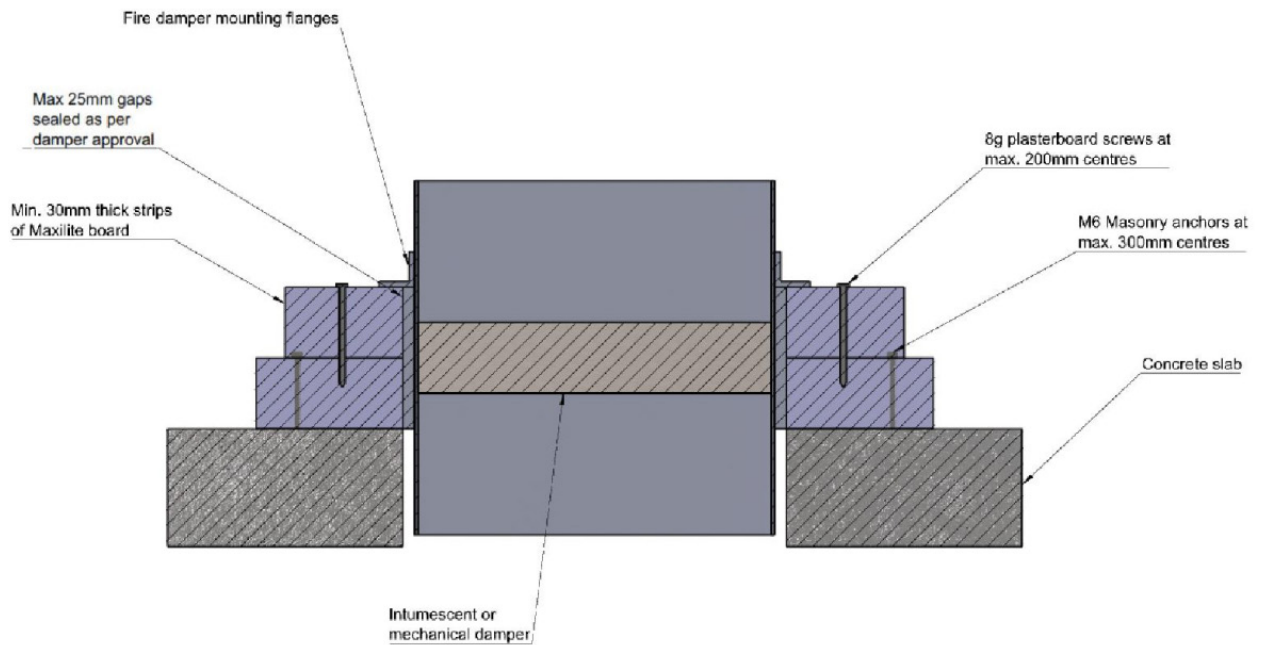

Installation Manual

Section C – FMD - 2

This installation detail involves flush fixing the min. 60mm Maxilite board to the slab. It can either be secured by a 50x50x0.9mm steel angle and using M6 masonry anchors at max. 300mm centres to secure to the slab. 8g screws at max. 200mm centres will be required to secure into the Maxilite.

The alternative fixing method requires a 60mm Maxilite strip instead of the angle which is secured into the slab using M6 masonry anchors at max. 300mm centres. 8g screws at max. 200mm centres will be required to secure into the Maxilite.

Key Details

- Damper sealed as per damper approval or with FyreFLEX
- All joins in Maxilite are sealed with FyreFLEX Sealant
- Max. 300mm centres for M6 masonry anchors securing Maxilite to slab
- Max. 200mm centres 8g plasterboard screw centres securing second Maxilite strip into the first.
- Fire damper is approved for use in slabs and installed as per manufacturers specifications

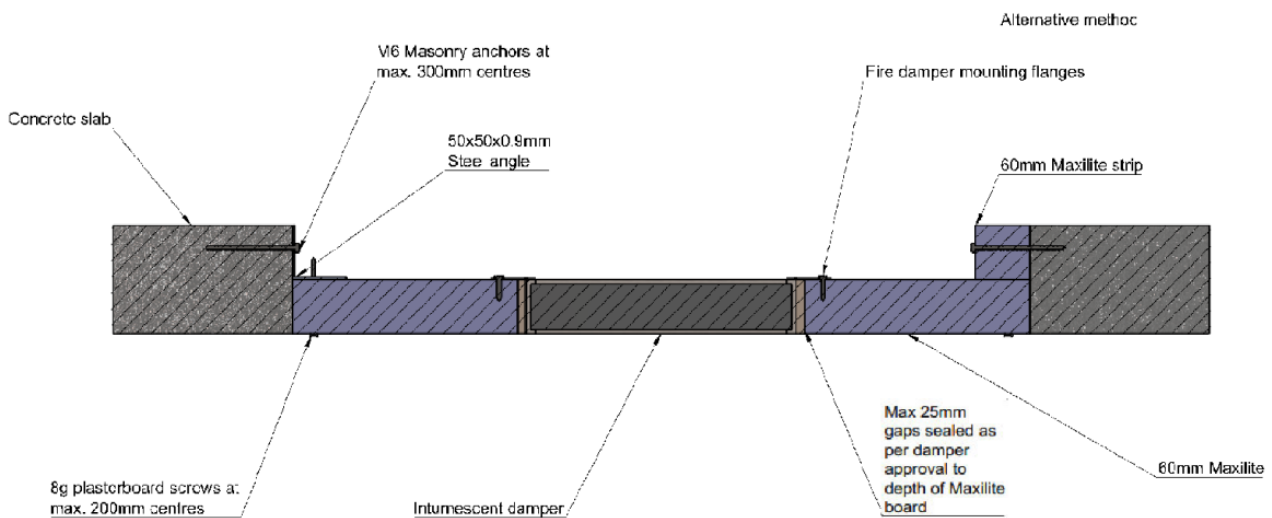

Installation Manual

Section C – FMD - 3

This installation detail consists of a panel of Maxilite, with an intumescent damper, fixed to underside of the slab opening.

Key Details

- Damper sealed as per damper approval or with FyreFLEX
- All joints in Maxilite are sealed with FyreFLEX Sealant
- Maxilite board overlaps the wall opening by at least 100mm
- Max. 300mm centres for M6 masonry anchors securing Maxilite to slab
- Fire damper is approved for use in slabs and installed as per manufacturers specifications

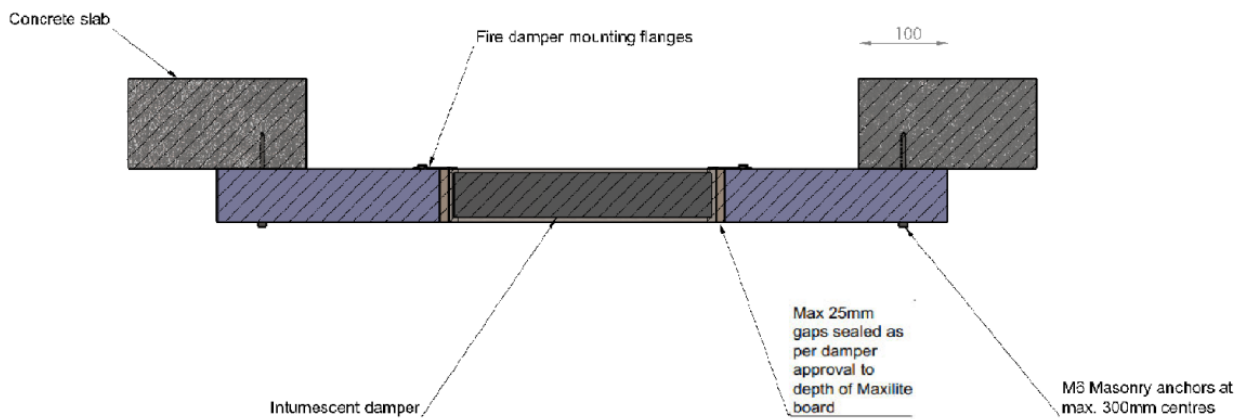

Installation Manual

Section C – FMD - 4

This installation detail consists of a panel of Maxilite, with an intumescent damper, fixed to top side of the slab opening.

Key Details

- Damper sealed as per damper approval or with FyreFLEX
- All joins in Maxilite are sealed with FyreFLEX Sealant
- Maxilite board overlaps the wall opening by at least 100mm
- Max. 300mm centres for M6 masonry anchors securing Maxilite to slab
- Fire damper is approved for use in slabs and installed as per manufacturers specifications

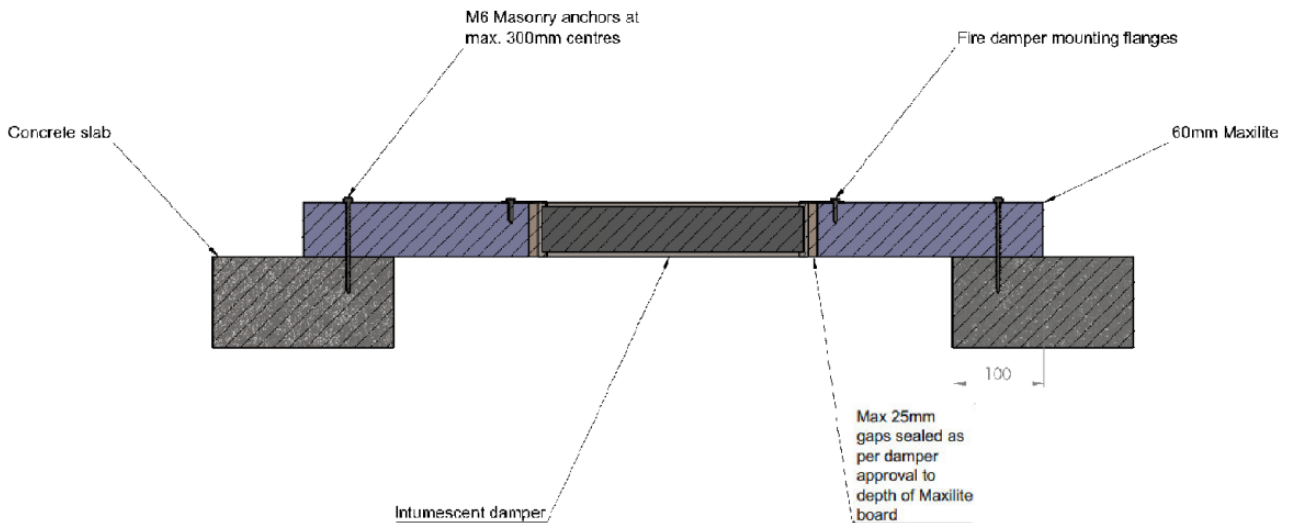

Installation Manual

Section C – FMD - 5

This installation detail consists of a min. 60mm panel of Maxilite with 75x75x2mm RHS cladded with min. 60mm Maxilite strips. The RHS is secured to the slab using M6 masonry anchors at max. 300mm centres. 10g screws at max. 300mm centres will be required to secure the RHS into the Maxilite.

For the alternative method, a 60mm Maxilite board is applied to the underside of the slab with 75x75x2mm RHS on the top side. The RHS is secured to the slab using M6 masonry anchors at max. 300mm centres. 10g screws at max. 300mm centres will be required to secure the RHS into the Maxilite.

Key Details

- Damper sealed as per damper approval or with FyreFLEX
- All joints in Maxilite are sealed with FyreFLEX Sealant
- Max. 300mm centres for M6 masonry anchors securing Maxilite to slab
- Max. 300mm centres for 10g screws will be required to secure the RHS into the Maxilite.
- The Maximum Maxilite panel size is 1500x1000mm
- Fire damper is approved for use in slabs and installed as per manufacturers specifications

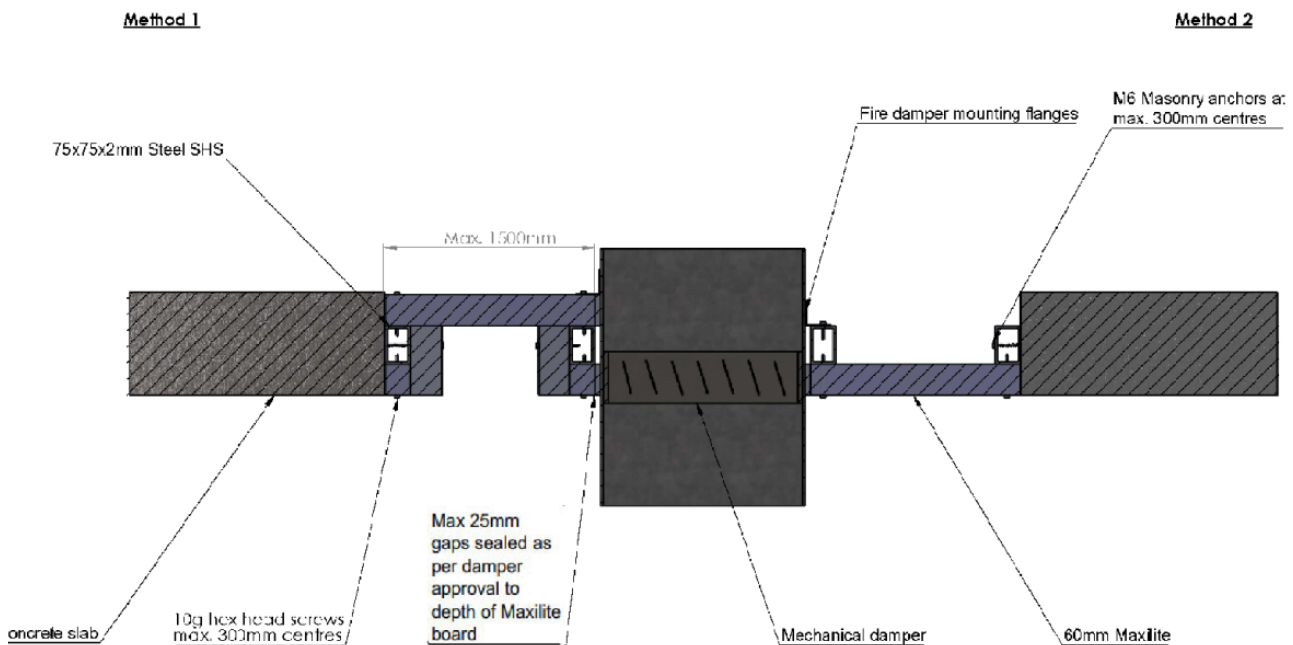

Installation Manual

Section C – FMD - 6

This installation detail consists of a min. 60mm panel of Maxilite with 75x75x2mm RHS cladded with min. 60mm Maxilite strips. 10g screws at max. 300mm centres will be required to secure the RHS into the Maxilite. A 50x50x0.9mm steel angle is required to fix the Maxilite board into the slab using M6 masonry anchors at max. 300mm centres. 8g screws at max. 300mm centres will be required to secure the angle into the Maxilite.

For the alternative method, a 60mm Maxilite board is applied to the underside of the 75x75x2m RHS. The RHS is secured to the Maxilite 10g screws at max. 300mm centres. A 60mm Maxilite strip will be required underneath the Maxilite board and secured into the slab using M6 masonry anchors at max. 300mm centres. 8g screws at max. 200mm centres will be required to secure the Maxilite strip into the Maxilite board.

Key Details

- Damper sealed as per damper approval or with FyreFLEX
- All joints in Maxilite are sealed with FyreFLEX Sealant
- Max. 300mm centres for M6 masonry anchors securing Maxilite to slab
- Max. 300mm centres for 10g screws will be required to secure the RHS into the Maxilite.
- The Maximum Maxilite panel size is 1500x1000mm
- Fire damper is approved for use in slabs and installed as per manufacturers specifications

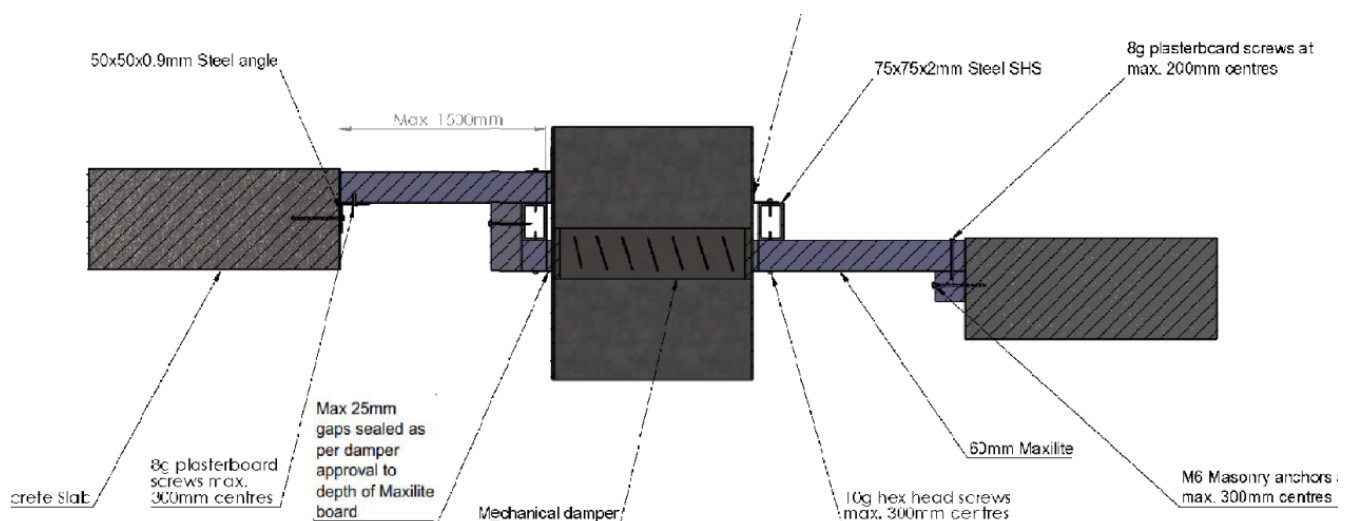

Installation Manual

Section C – FMD - 7

This installation detail involves flush fixing min. 30mm Maxilite strips to 1-4 sides of the opening within a slab. M6 masonry anchors at max. 300mm centres are required to fix the maxilite board strips to the slab. M6 masonry anchors at max. 300mm centres are required to fix the damper to the slab.

Key Details

- Damper sealed as per damper approval or with FyreFLEX
- All joins in Maxilite are sealed with FyreFLEX Sealant
- Max. 300mm centres for M6 masonry anchors securing Maxilite to slab
- Max. 300mm centres for M6 masonry anchors securing damper to the slab
- The Maximum Maxilite panel size is 1500x1000mm
- Fire damper is approved for use in slabs and installed as per manufacturers specifications

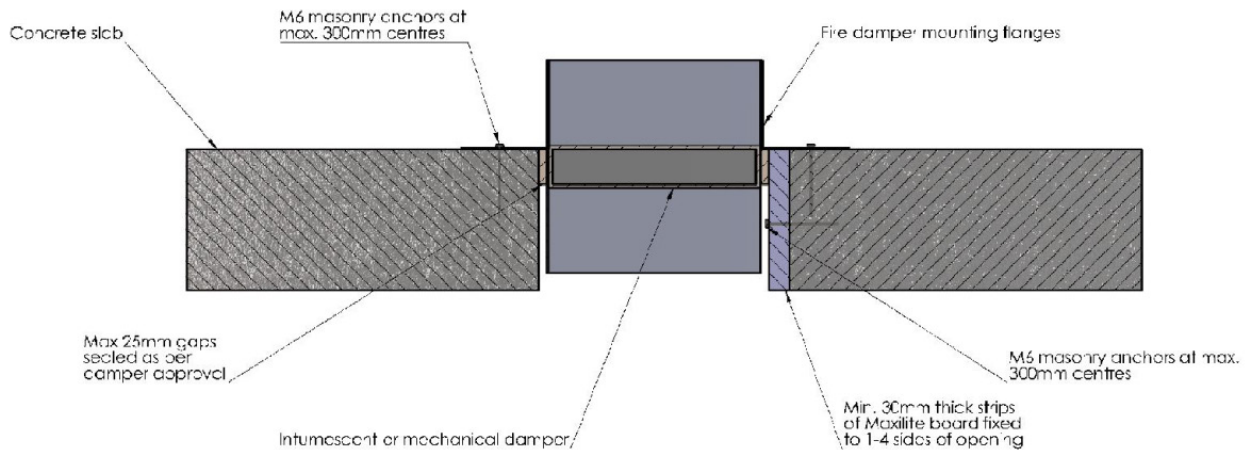

Installation Manual

Section D– Speedpanel & Damper Detail

This installation detail consists of a min. 20mm Maxilite board to be secured to the slab soffit using M6 masonry anchors at max. 300mm centres with the length of Maxilite being damper dependent.

Key Details

- Damper sealed as per damper approval or with FyreFLEX
- All joins in Maxilite are sealed with FyreFLEX Sealant.
- Fire damper is approved for use in 78mm Speedpanel walls and installed as per manufacturers specifications
- Max. 300mm centres for M6 masonry anchors securing Maxilite to soffit

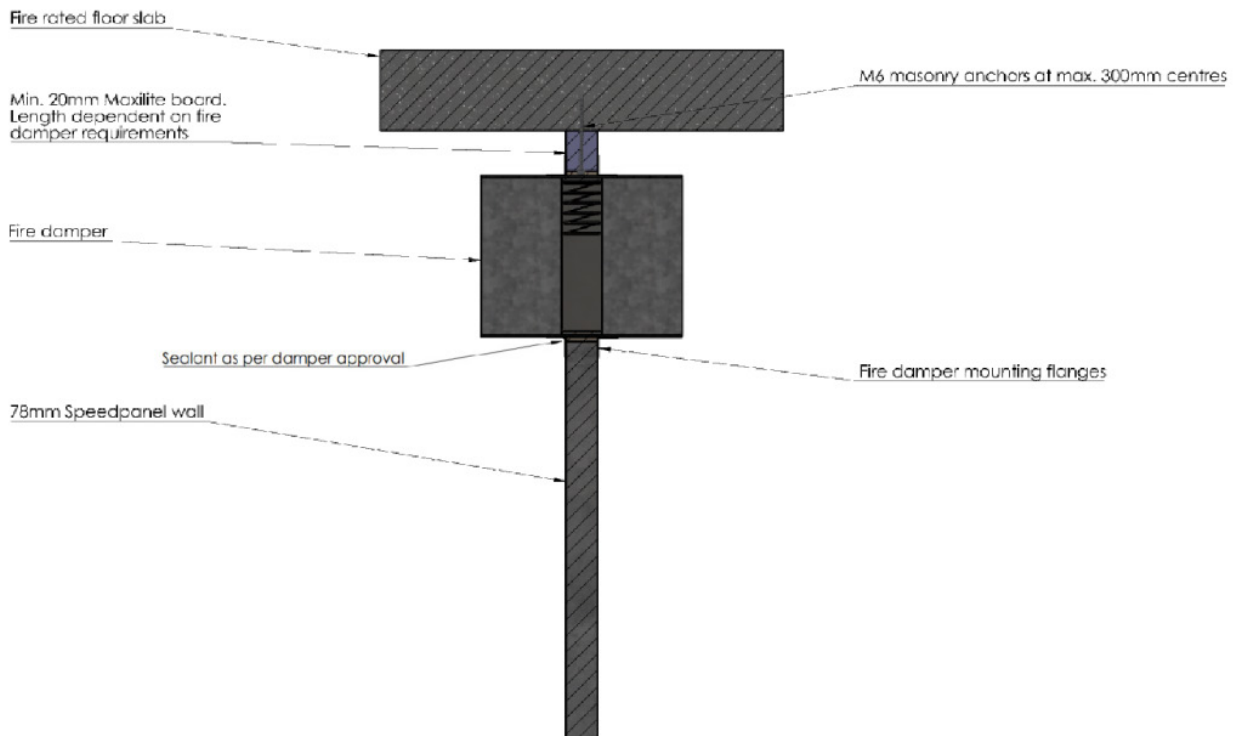

PRODUCT RANGE

FyreBOARD MAXILITE

Item number	Description	Min Order Qty	Pallet Qty	Weight Per Board
Maxilite White 30	Maxilite board 1525x1000x30 mm (white)	1x	30	16kg
Maxilite White 40	Maxilite board 1525x1000x40 mm (white)	1x	22	22kg
Maxilite White 60	Maxilite board 1525x1000x60 mm (white)	1x	12	32kg
Maxilite Blue 30	Maxilite board 2040x1220x30 mm (blue)	1x	35	23kg
Maxilite Blue 40	Maxilite board 2040x1220x40 mm (blue)	1x	23	30kg
Maxilite Blue 60	Maxilite board 2040x1220x60 mm (blue)	1x	17	45kg
Maxilite Half White 30	Maxilite board 1018x1220x30 mm (white)	1x	39	11.5kg
Maxilite Half White 40	Maxilite board 1018x1220x40 mm (white)	1x	10	15kg
Maxilite Half White 60	Maxilite board 1018x1220x60 mm (white)	1x	29	22.5kg
Maxilite Half Blue 30	Maxilite board 1018x1220x30 mm (blue)	1x	61	11.5kg
Maxilite Half Blue 40	Maxilite board 1018x1220x40 mm (blue)	1x	74	15kg
Maxilite Half Blue 60	Maxilite board 1018x1220x60 mm (blue)	1x	34	22.5kg
Maxilite Quarter White 40	Maxilite board 790 x497x 40mm (white)	1x	20	5kg
Maxilite Quarter White 60	Maxilite board 790 x497x60mm (white)	1x	20	7.5kg
Maxilite Quarter Blue 40	Maxilite board 790 x497x 40mm (blue)	1x	20	5kg
Maxilite Quarter Blue 60	Maxilite board 790 x497x 60mm (blue)	1x	20	7.5kg

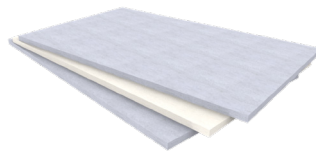

FyreFLEX

Item number (fishbowl code)	Description	Min Order Qty	Pallet Qty
FyreFLEX 300W FyreFLEX 300G	FyreFLEX® Sealant Cartridge 300ml White or Grey	20	1440
FyreFLEX 600W FyreFLEX 600G	FyreFLEX® Sealant Sausage 600ml White or Grey	18	810
FyreFLEX 10W FyreFLEX 10G	FyreFLEX® Sealant Pail 10L White or Grey	1	110



Fire Rated Air Transfer Grilles

Maxilite Bulkheads & Ceilings

Key Details

- ① Maxilite Bulkhead/Ceiling, construction as per FCO 2586
- ② 25 x 50 x 0.9mm Fixing angles, or angles otherwise approved by Lorient for the LVH44 system
- ③ 30mm Maxilite Cover strip
- ④ LVH44 Lorient Air Transfer Grille
- ⑤ 8g x 45mm screws at 200mm centres
- ⑥ Angles fixed to damper with steel fasteners at 150mm centres
- ⑦ 12mm x 24mm wire mesh with 75mm projection and 40mm aperture overlap fixed to Maxilite with 8g x 45mm screws

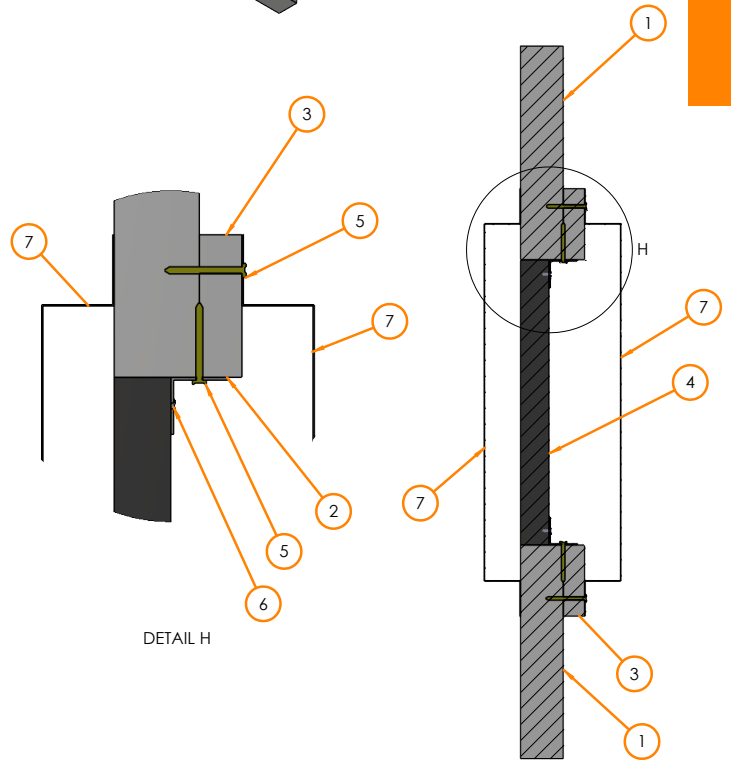
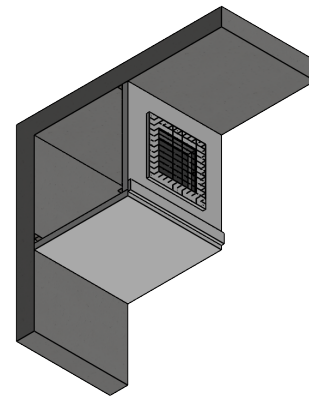

LVH44 Air Transfer Grille
-/120/120 FRL in Maxilite

Fire Resistance in accordance with
AS1530.4:2014

Approval Reference

FCO 2586 & EWFA 55202900

Max Size

600 x 600mm in Maxilite

Installation Instructions

- Cut hole to desired dimension up to 600 x 600mm in Maxilite Ceilings Construction, referencing FCO 2586 for limitations on the hole location.
- Mechanically fix angle brackets, following the standard details for the damper cell as tested and approved by Lorient for the LVH44 system.
- Ensure to fit 30mm Maxilite cover strips (item #3) to keep strict compliance with FCO 2586.

FAQ?

Q What is the maximum size of the damper?

A The maximum size damper approved with FyreBOARD Maxilite is 800 x 800mm

Q Why don't these systems get insulation performance?

A Conforming to AS1668.1-2015 section 3.2.3, fire dampers do not require insulation where dampers are shaft mounted or connected to duct work complying with Clause 2.3.2 and with minimum duct length of 2m.

Q Can I paint over Maxilite?

A Yes, it is possible to paint over the board. Maxilite is porous so multiple coats are recommended.

Q Do the fixings require FyreFLEX sealant where the FyreBOARD Maxilite is penetrated?

A FyreFLEX sealant is not required for the fixings. Make sure FyreFLEX is bedded between different layers of Maxilite and joints

Q Does the damper brand matter?

A No, FyreBOARD Maxilite is approved with fire dampers that have been installed as per damper manufacturer instructions.

Q What is the maximum single sheet size of the FyreBOARD Maxilite panel for damper upgrade?

A Maximum size of the Maxilite panel is limited to a single sheet of 1200 x 1200mm or 1500 x 1000mm

SOCIAL MEDIA

