



Fire assessment report



The bushfire performance of metal sheet or concrete / terracotta tile roof systems protected with Trafalgar Fire BAL FZ roof protection systems

Sponsor: Trafalgar Group Pty Ltd.

Report number: FAS230057 Revision: R2.1

Issued date: 10 July 2024 Expiry date: 30 June 2028

Quality management

Version	Date	Information about the report			
R1.0	Issue: 19 Jun 2023	Reason for issue	Initial issue		
		Name	Prepared by Kimal Wasalathilake	Reviewed by Omar Saad	Authorised by Imran Ahamed
R1.1	Issue: 30 Jun 2023	Reason for issue	Changing the name of rockwool insulation to Trafalgar TRock Insulation blanket		
		Name	Prepared by Kimal Wasalathilake	Reviewed by Omar Saad	Authorised by Omar Saad
R2.0	Issue: 11 Jun 2024	Reason for issue	Including the option to vertically install the top hats on Trafalgar Fire BoardeX (section 6.3.13).		
		Name	Prepared by Kimal Wasalathilake	Reviewed by Omar Saad	Authorised by Omar Saad
R2.1	Issue: 10 Jul 2024	Reason for issue	Revised with typographical amendments		
	Expiry: 30 Jun 2028	Name	Prepared by Zakaria Awad	Reviewed by Alim Rasel	Authorised by Alim Rasel
		Signature			

*As used herein, The name "Warringtonfire" and its associated IP and branding is used by Warringtonfire Australia Pty Limited in Australia under licence from Warringtonfire Testing and Certification Limited (based in the UK) for a transitional period following the acquisition of Warringtonfire Australia Pty Limited. The Warringtonfire Testing and Certification Limited continues to own the rights to "Warringtonfire" and continues to operate the global "Warringtonfire business" outside of Australia.

Executive summary

This report documents the findings of the assessment undertaken to determine the expected bushfire attack level (BAL) of metal sheet or concrete / terracotta tile roof systems protected with Trafalgar Fire BAL FZ roof protection systems in accordance with AS 1530.8.2:2018.

The analysis in sections 5 to 7 of this report found that the proposed systems, together with the described variations, are expected to achieve BAL FZ as shown in Table 1 – in accordance with AS 1530.8.2:2018.

The variations and outcomes of this assessment are subject to the limitations and requirements described in sections 2, 3 and 8 of this report. The results of this report are valid until 30 June 2028.

Table 1 Variations and assessment outcome

Item	Reference tests	Description	Variations	BAL rating
Metal sheet roof	FRT220335 R1.0 EWFA 2394700.1	FRT220335 R1.0 included a straight section of a metal sheet roof protected with Trafalgar Fire BAL FZ roof protection system tested in accordance with AS 1530.8.2:2018. EWFA 2394700.1 included a valley junction system of a similar metal sheet clad roof system tested in accordance with AS 1530.8.2:2007.	<p>The following variations are to be assessed in accordance with AS 1530.8.2:2018 using the results of the referenced tests:</p> <ul style="list-style-type: none"> The roofing finish can be Colorbond® or Zinalume®. The roof sheet profile can be chosen from various steel sheet profiles such as Colorbond®, Zinalume®, KLIP-LOK Hi-Strength, with a thickness of 0.42 or 0.6 BMT. The roof framing can be constructed using either trusses or rafters made from light gauge steel or timber with a maximum spacing of 600 mm. Inclusion of Metal fascia board Inclusion of barge and gable detail as shown in Figure 4 Inclusion of hip and ridge detail as shown in Figure 5 The ridge capping can be scribed or un-scribed. 12.5 mm or 15 mm thick Trafalgar Fire Boardex can be fixed to framing with 38 mm screws instead of staples. Inclusion of valley details as tested in BWA 2394700.1, except valley backed with Trafalgar Fire Boardex and 25 mm Siderise Spandrel Board as tested in FRT220335 R1.0 (Figure 6). The top hats can be installed vertically on top of Trafalgar Fire Boardex (Figure 16 – Figure 17). 	BAL FZ

Item	Reference tests	Description	Variations	BAL rating
Concrete or terracotta tile roof	FRT220335 R1.0 EWFA 2368000.1 EWFA 2398800.1 EWFA 2434700 BWA 2358300 BWA 2367700	EWFA 2368000.1 included a concrete tile roof system incorporating plywood roof lining tested in accordance with AS 1530.8.2:2007. EWFA 2398800.1 included a concrete tile roof system incorporating a valley gutter system tested in accordance with AS 1530.8.2:2007. BWA 2358300, BWA 2367700 and EWFA 2434700 included vertical roofing systems with a plywood substrate and fibreglass blanket insulation tested in general accordance with AS 1530.8.2:2007.	<p>The following variations are to be assessed in accordance with AS 1530.8.2:2018 using the results of the referenced tests.</p> <ul style="list-style-type: none"> The roof cladding options include concrete or terracotta tiles, with variations in profile and mass ranging from 46 kg/m² to 54 kg/m² The roof framing can be constructed using either trusses or rafters with a maximum spacing of 600 mm. 50 mm thick Trafalgar Fire rockwool insulation with foil face on the top face (nominal density of 60 kg/m³ as the roof cavity insulation Inclusion of typical barge and gable (Figure 10), hip (Figure 11), and valley (Figure 12) details Roofing battens to be installed vertically (parallel to roof frame timbers) and incorporate horizontal roof tile battens as tested in EWFA 2368000.1 and EWFA 2398800.1. 	

Contents

1.	Introduction.....	6
2.	Framework for the assessment.....	6
2.1	Assessment approach.....	6
2.2	Declaration.....	7
3.	Requirements and limitations of this assessment.....	7
4.	Description of the specimen and variations.....	8
4.1	Description of assessed systems.....	8
4.2	Referenced test data.....	8
4.3	Variations to the tested systems.....	8
4.4	Test standard.....	10
4.5	Schedule of components.....	10
5.	Relevance of AS 1530.8.2:2007 test data with respect to AS 1530.8.2:2018.....	33
5.1	Description of variation.....	33
5.2	Methodology.....	33
5.3	Assessment.....	33
5.4	Conclusion.....	34
6.	Assessment of metal sheet roof system.....	35
6.1	Description of variation.....	35
6.2	Methodology.....	35
6.3	Assessment.....	35
6.4	Conclusion.....	40
7.	Assessment of concrete or terracotta tile roof system.....	42
7.1	Description of variation.....	42
7.2	Methodology.....	42
7.3	Assessment.....	42
7.4	Conclusion.....	45
8.	Validity.....	47
Appendix A	Drawings and additional information.....	48
Appendix B	Summary of supporting test data.....	49

1. Introduction

This report documents the findings of the assessment undertaken to determine the expected bushfire attack level (BAL) of metal sheet or concrete / terracotta tile roof systems protected with Trafalgar Fire BAL FZ roof protection systems in accordance with AS 1530.8.2:2018¹.

This report may be used as evidence of suitability in accordance with the requirements of the relevant National Construction Code (NCC) to support the use of the material, product, form of construction or design as given within the scope of this assessment report. It also references test evidence for meeting deemed to satisfy (DTS) provisions of the NCC that apply to the assessed systems.

This assessment was carried out at the request of Trafalgar Group Pty Ltd..

The sponsor details are included in Table 2.

Table 2 Sponsor details

Sponsor	Address
Trafalgar Group Pty Ltd.	26a Ferndell Street South Granville NSW 2142 Australia

2. Framework for the assessment

2.1 Assessment approach

An assessment is a professional opinion about the expected performance of a component or element of structure subjected to a fire test.

No specific framework, methodology, standard or guidance documents exists in Australia for undertaking these assessments. We have therefore followed the 'Guide to undertaking technical assessments of the fire performance of construction products based on fire test evidence' prepared by the Passive Fire Protection Forum (PFPF) in the UK in 2021².

This guide provides a framework for undertaking assessments in the absence of specific fire test results. Some areas where assessments may be offered are:

- Where a modification is made to a construction which has already been tested
- The interpolation or extrapolation of results of a series of fire resistance tests, or utilisation of a series of fire test results to evaluate a range of variables in a construction design or a product
- Where, for various reasons – eg size or configuration – it is not possible to subject a construction or a product to a fire test.

Assessments can vary from relatively simple judgements on small changes to a product or construction through to detailed and often complex engineering assessments of large or sophisticated constructions.

This assessment uses established empirical methods and our experience of fire testing similar products to extend the scope of application by determining the limits for the design and performance based on the tested constructions and performances obtained. The assessment is an evaluation of the potential bushfire attack level of the elements in accordance with AS 1530.8.2:2018.

¹ Standards Australia, 2018, Methods for fire tests on building materials, components and structures – Part 8.2: Tests on elements of construction for buildings exposed to simulated bushfire attack – Large flaming sources, AS 1530.8.2:2018, Standards Australia, NSW.

² Passive Fire Protection Forum (PFPF), 2021, Guide to undertaking technical assessments of the fire performance of construction products based on fire test evidence, Passive Fire Protection Forum (PFPF), UK.

This assessment has been written in accordance with the general principles outlined in EN 15725:2010³ for extended application reports on the fire performance of construction products and building elements.

This assessment has been written using appropriate test evidence generated at accredited laboratories to the relevant test standard. The supporting test evidence has been deemed appropriate to support the manufacturer's stated design.

2.2 Declaration

The 'Guide to undertaking technical assessments of the fire performance of construction products based on fire test evidence' prepared by the PFPF in the UK requires a declaration from the client. By accepting our fee proposal on 30 March 2023, Trafalgar Group Pty Ltd. confirmed that:

- To their knowledge, the variations to the component or element of structure, which is the subject of this assessment, have not been subjected to a fire test to the standard against which this assessment is being made.
- They agree to withdraw this assessment from circulation if the component or element of structure is the subject of a fire test by a test authority in accordance with the standard against which this assessment is being made and the results are not in agreement with this assessment.
- They are not aware of any information that could adversely affect the conclusions of this assessment and – if they subsequently become aware of any such information – they agree to ask the assessing authority to withdraw the assessment.

3. Requirements and limitations of this assessment

- The scope of this report is limited to an assessment of the variations to the tested systems described in section 4.3.
- This report details the methods of construction, test conditions and assessed results expected in accordance with AS 1530.8.2:2018.
- This assessment applies to roofing systems with the external side exposed to the heating conditions specified in AS 1530.8.2:2018.
- The framing of the roof system and safe spans of battens must be sized and designed by a professional structural engineer according to relevant standards, considering design actions at ambient and elevated temperatures.
- This report is only valid for the assessed systems and must not be used for any other purpose. Any changes with respect to size, construction details, loads, stresses, edge or end conditions – other than those identified in this report – may invalidate the findings of this assessment. If there are changes to the system, a reassessment will need to be done by an Accredited Testing Laboratory (ATL) that is accredited to the same nominated standards of this report.
- The documentation that forms the basis for this report is listed in Appendix A and Appendix B.
- This report has been prepared using on information provided by others. Warringtonfire has not verified the accuracy and/or completeness of that information and will not be responsible for any errors or omissions that may have been incorporated into this report as a result.
- This assessment is based on the proposed systems being constructed under comprehensive quality control practices and following appropriate industry regulations and Australian Standards on quality of materials, design of structures, guidance on workmanship and expert handling, placing and finishing of the products on site. These variables are beyond the control and consideration of this report.

³ European Committee for Standardization, 2010, Extended application reports on the fire performance of construction products and building elements, EN 15725:2010, European Committee for Standardization, Brussels, Belgium

4. Description of the specimen and variations

4.1 Description of assessed systems

The assessed system is roof systems cladded with metal sheets, concrete tiles, or terracotta tiles, which are protected by Trafalgar Fire BAL FZ roof protection elements.

The steel roof sheeting can have different profiles with a minimum base metal thickness (BMT) of 0.42 mm. The concrete and terracotta roof tiles can be of various profiles ranging from 46 kg/m² to 54 kg/m².

4.2 Referenced test data

The assessment of the variation to the tested systems and the determination of the expected performance is based on the results of the fire tests documented in the reports summarised in Table 3. Further details of the tested systems are included in Appendix B.

Table 3 Referenced test data

Report number	Test sponsor	Test date	Testing authority
FRT220335 R1.0	Trafalgar Group Pty Ltd.	09 February 2023	Warringtonfire
EWFA 2394700.1	Forest and Wood Products Australia	25 September 2009	Exova Warringtonfire Aus Pty Ltd
EWFA 2368000.1	Roofing Tile Association of Australia	13 August 2009	Exova Warringtonfire Aus Pty Ltd
EWFA 2398800.1		18 August 2009	Exova Warringtonfire Aus Pty Ltd
EWFA 2434700		23 December 2009	Exova Warringtonfire Aus Pty Ltd
BWA 2358300		23 June 2009	Bodycote Warringtonfire (Aus) Pty Ltd
BWA 2367700		23 June 2009	Bodycote Warringtonfire (Aus) Pty Ltd

4.3 Variations to the tested systems

The tested systems and variations to those tested system/s – together with the referenced standard fire tests – are described in Table 4.

Table 4 Variations to tested systems

Item	Reference test	Description	Variations
Metal sheet roof	FRT220335 R1.0 EWFA 2394700.1	FRT220335 R1.0 included a straight section of a metal sheet roof protected with Trafalgar Fire BAL FZ roof protection system tested in accordance with AS 1530.8.2:2018. EWFA 2394700.1 included a valley junction system of a similar metal sheet clad roof system tested in accordance with AS 1530.8.2:2007 ⁴ .	The following variations are to be assessed in accordance with AS 1530.8.2:2018 using the results of the referenced tests: <ul style="list-style-type: none"> • The roofing finish can be Colorbond® or Zinalume®. • The roof sheet profile can be chosen from various steel sheet profiles such as Colorbond®, Zinalume®, KLIP-LOK Hi-Strength, with a thickness of 0.42 or 0.6 BMT. • The roof framing can be constructed using either trusses or rafters made from light gauge steel or timber with a maximum spacing of 600 mm. • Inclusion of Metal fascia board • Inclusion of barge and gable detail as shown in Figure 4 • Inclusion of hip and ridge detail as shown in Figure 5 • The ridge capping can be scribed or un-scribed. • 12.5 mm or 15 mm thick Trafalgar Fire BoardeX can be fixed to framing with 38 mm screws instead of staples. • Inclusion of valley details as tested in BWA 2394700.1, except valley backed with Trafalgar Fire BoardeX and 25 mm Siderise Spandrel Board as tested in FRT220335 R1.0 (Figure 6). • The top hats can be installed vertically on top of Trafalgar Fire BoardeX (Figure 16 – Figure 17).

⁴ Standards Australia, 2007, Methods for fire tests on building materials, components and structures – Part 8.2: Tests on elements of construction for buildings exposed to simulated bushfire attack – Large flaming sources, AS 1530.8.2:2007, Standards Australia, NSW.

Item	Reference test	Description	Variations
Concrete or terracotta tile roof	FRT220335 R1.0 EWFA 2368000.1 EWFA 2398800.1 EWFA 2434700 BWA 2358300 BWA 2367700	EWFA 2368000.1 included a concrete tile roof system incorporating plywood roof lining tested in accordance with AS 1530.8.2:2007. EWFA 2398800.1 included a concrete tile roof system incorporating a valley gutter system tested in accordance with AS 1530.8.2:2007. BWA 2358300, BWA 2367700 and EWFA 2434700 included vertical roofing systems with a plywood substrate and fibreglass blanket insulation tested in general accordance with AS 1530.8.2:2007.	The following variations are to be assessed in accordance with AS 1530.8.2:2018 using the results of the referenced tests. <ul style="list-style-type: none"> The roof cladding options include concrete or terracotta tiles, with variations in profile and mass ranging from 46 kg/m² to 54 kg/m² The roof framing can be constructed using either trusses or rafters with a maximum spacing of 600 mm. 50 mm thick Trafalgar Fire rockwool insulation with foil face on the top face (nominal density of 60 kg/m³ as the roof cavity insulation Inclusion of typical barge and gable (Figure 10), hip (Figure 11), and valley (Figure 12) details Roofing battens to be installed vertically (parallel to roof frame timbers) and incorporate horizontal roof tile battens as tested in EWFA 2368000.1 and EWFA 2398800.1.

4.4 Test standard

AS 1530.8.2:2018 provides methods for determining the performance of external construction elements when exposed to direct flame impingement from the fire front.

The methods simulate exposure to direct flame impingement from the fire front or large burning items such as other burning buildings or adjacent isolated trees and shrubs by utilising the standard heating regime of AS 1530.4:2014⁵.

4.5 Schedule of components

Table 5 outlines the schedule of components for the assessed systems. Figure 1 to Figure 15 show the assessed systems.

Table 5 Schedule of components of assessed systems

Item	Description	
1.	Name	Trafalgar Fire BoardeX
	Material	Glass fibre reinforced, water and mould resistant gypsum board
	Size	12.5 mm or 15 mm thick
	Density	Nominal 900 kg/m ³

⁵ Standards Australia, 2014, Methods for fire tests on building materials, components and structures – Part 4: Fire-resistance tests for elements of construction, AS 1530.4:2014, Standards Australia, NSW.

Item	Description	
	Installation	<p>Cut to size (score and snap) and installed directly over framing to completely encapsulate the frame of the roof, fascia, and eave elevations, ensuring that all joints and abutments finish on either the frame or noggins.</p> <p>A minimum 6 mm bead of TREMstop PU + sealant (Item 19) is to be applied around the perimeter of the boards. The boards are tightly butted up to each other at the joints and abutments, ensuring there are no gaps as the sealant squidges to the top face of the boards.</p> <p>They are then secured to either of the following frame types:</p> <ul style="list-style-type: none"> • Timber frame – Using 38 mm Crown Head staples (Item 21A) or 38 mm Drywall needlepoint screws (Item 21B) for fixing centres. • Steel frame – Using 38 mm long Drywall self-drilling Screws (Item 21C) for fixing centres.
2.	Name	Trafalgar Fire Siderise Spandrel board
	Material	Rigid rockwool insulation board with an Alfoil bonded to one side
	Size	25 mm thick
	Density	Nominal 160 kg/m ³
	Installation	To be installed over the top of the Trafalgar Fire BoardeX (Item 1) to the fascia, barge, eave and to the perimeter of the roof and to the valley sections using screws (Items 21E or 21G).
3.	Name	Trafalgar TRock Insulation blanket
	Material	Flexible rockwool insulation roll with an Alfoil bonded to one side
	Size	Standard roll size 5000 mm × 1200 mm × 50 mm thick
	Weight	Nominal 60 kg/m ³
	Installation	<p>Steel sheet roof:</p> <p>Laid directly over the top of the steel top hats (Item 4) & the Trafalgar Fire BoardeX (Item 1) with the foil face, facing down, ensuring that the foil tongues sit under each abutting roll and continue into the gutter/valley by a minimum of 75 mm. An additional layer of insulation must be installed under the ridge capping, ensuring that it is positioned at least 40 mm back from the bottom of the two lips of the ridge capping to prevent wicking.</p> <p>Tile roof:</p> <p>Laid directly over the top of the roof tile battens (Item 12) and the Trafalgar Fire BoardeX (Item 1) and under the roof tile counter battens (Item 13). An additional layer of insulation must be installed under the ridge and hip capping, ensuring that it is positioned at least 30 mm back from the bottom of the two lips of the ridge capping to prevent wicking.</p>
4.	Name	Steel top hat roofing batten (Steel sheet roof applications)
	Material	Mild steel
	Size	Nominal 40 mm high × 40 mm wide at the top and 95 mm wide at the base, this includes a nominal 15 mm wide lip on each side
	Installation	Installed across or along the rafters and screw fixed through the Trafalgar Fire BoardeX (Item 1) to the rafters at 600 mm centres using 65 mm screws at rafter centres.
5.	Name	Steel roof sheeting (Steel sheet roof applications)
	Material	Mild steel
	Size	Various profiles of steel sheeting with a minimum BMT of 0.42 mm manufactured in accordance with AS 1445:2013 ⁶ .

⁶ Standards Australia, 2013, Hot-dipped zinc-coated, aluminium/zinc-coated or aluminium/zinc/magnesium-coated steel sheet — 76 mm pitch corrugated, AS 1445:2013, Standards Australia, NSW.

Item	Description	
	Installation	<p>For horizontal top hats –</p> <p>Roof sheeting is installed to steel battens (Item 4) by one fixing (Item 21G) every second corrugation on the top and bottom battens and by at least one fixing every fifth corrugation in the field of the sheeting. At the edges of the roof, at locations such as the fascia and hip, the sheet shall be fixed at every second corrugation. For roof sheeting that has angled cuts, such as at valleys, fixing shall be at every corrugation.</p> <p>For vertical top hats –</p> <p>Roof sheeting is installed to steel battens (Item 4) by one fixing (Item 21G) at 150 mm centres on the top and bottom battens and at 385 mm centres in the field of the sheeting. At the edges of the roof, at locations such as the fascia and hip, the sheet shall be fixed at 150 mm centres. For roof sheeting that has angled cuts, such as at valleys, fixing shall be at 75 mm centres.</p>
6.	Name	Steel ridge capping (Steel sheet roof applications)
	Material	Mild steel galvanised or painted
	Size	Each leg of the angle capping is minimum 190 mm long with a minimum BMT of 0.42 mm
	Installation	Ridge capping installed over the ridge of the roof and installed on steel battens by one fixing (Item 21G) every third corrugation.
7.	Name	Valley gutter
	Material	Mild steel
	Size	Minimum 330 mm straight across after installation in the valley. Each leg must be a minimum 195 mm long with a minimum 0.55 BMT with a nominal 12 mm long lip.
	Installation	<p>Steel sheet roof:</p> <p>Secured through the valley lining into the roof lining with screws (Item 21G) at nominal 300 mm centres down both sides.</p> <p>Tile roof:</p> <p>Located within the valley formed in the specimen on top of the counter battens. Secured to the counter battens with screws (Item 21G) at nominal 300 mm centres down both sides.</p>
8.	Name	Barge board capping (Steel sheet roof applications)
	Material	Mild steel
	Size	Minimum 150 mm wide with a minimum 75 mm leg and a minimum 0.42 mm BMT
	Installation	Barge board capping shall be fixed by one screw (Item 21G) every third corrugation to the roof sheeting or to the batten.
9.	Name	Roof framing (timber or steel)
	Material	Timber frame
	Size	Solid timber framing or timber trusses shall be sized in accordance with the relevant framing and design standards.
	Installation	Spaced at maximum 600 mm centres based on the appropriate structural design of the framing/truss's battens.
	Or	
	Material	Steel frame
	Size	Steel framing or steel trusses shall be designed in accordance with the relevant framing and design standards.
	Installation	Spaced at maximum 600 mm centres based on the appropriate structural design of the framing/truss's battens.
10.	Name	Adjacent wall construction

Item	Description	
	Description	The wall to which this BAL FZ Roof System abuts must be a wall that has been tested or assessed to achieve the performance level of BAL FZ in accordance with AS 1530.8.2:2018 or AS 3959:2018 ⁷ .
11.	Name	Roof tiles
	Material	Concrete and terracotta roof tiles shall be of various profiles in accordance with AS 2049:2002 ⁸ . The tile may vary in mass from 46 kg/m ² to 54 kg/m ² . The tile profile shall vary from curved to flat and it is required that the gap requirements of AS 2049 Clause 5.3 are met when tested to AS 4046.1:2002 ⁹ .
	Installation	Each tile must be screw fixed or clip fixed to the tile battens.
12.	Name	Roof tile batten (tile roof applications)
	Material	Light gauge steel nominally 25 mm wide × 20 mm high
	Installation	Designed for framing spacing and fixed to the roof framing in accordance with the relevant structural standards.
13.	Name	Counter batten (tile roof applications)
	Material	40 mm wide at the top, 95 mm wide at the base, which includes a nominal 14 mm lip on both sides, and 40 mm high.
	Installation	Screw fixed to rafter/top chord framing through the face of the top hat using screws spaced at nominal 400 mm centres or as required by relevant structural standards.
14.	Name	Ridge capping (tile roof applications)
	Material	Concrete or Terracotta
	Size	440 mm long × nominal 250 mm wide × nominal 70 mm high × nominal 15 mm thick.
	Installation	Ridge capping installed over the ridge of the roof, with an approximate 20 mm overlap from one ridge tile to the next and set with bedding mortar (Item 15).
15.	Name	Bedding mortar (Tile roof applications)
	Material	Cement 4:1
	Size	40 mm thick
16.	Name	Valley guard (tile roof applications)
	Material	Mild steel
	Size	60 mm wide at the top, 80 mm wide at the base × 65 mm high, with a 40 mm wide flange on each side with an 8 mm lip on each edge of the flange.
	Installation	Installed on top of the valley gutter.
17.	Name	Anti-Ponding board (tile roof applications)
	Material	Trafalgar Fire BoardEX (Item 1)
	Size	300 mm wide × minimum 12.5 mm thick
	Installation	Screw fixed to counter battens (Item 13) over the roof cavity insulation (Item 3).
18.	Name	Barge board capping (tile roof applications)
	Material	Concrete or Terracotta
	Size	15 mm thick
	Installation	Barge capping is installed over the fascia/barge board, with an approximate 20 mm overlap and set with bedding mortar (Item 15)
19.	Name	TREMstop PU + sealant

⁷ Standards Australia, 2018, Construction of buildings in bushfire-prone areas, AS 3959:2018, Standards Australia, NSW.

⁸ Standards Australia, 2002, Roof tiles, AS 2049:2002, Standards Australia, NSW.

⁹ Standards Australia, 2002, Methods of testing roof tiles, Method 1: Determination of distortion, AS 4046.1:2002, Standards Australia, NSW.

Item	Description	
	Material	1 part polyurethane water- and fire-resistant sealant
	Size	600 ml sausages
	Installation	A minimum 6 mm bead of TREMstop PU+ sealant is applied around the perimeter of the boards and the boards are tightly butted up to each other at the joints and abutments, ensuring there are no gaps.
20.	Name	Trafalgar Fyreflex
	Material	Acrylic fire-resistant sealant
	Size	310 ml cartridges or 600 ml sausages, or 10 litre tubs of brush grade
21.	Name	Fixings
	A	38mm × 18 gauge, narrow or wide Galvanised Crown Head Staples
	B	38mm × 3.5g Drywall Needlepoint Screws
	C	38mm × 3.5g Drywall Self-drilling Screws
	D	25mm × 11g Hex Head Timber Screws with Seal
	E	50mm × 12g Hex Head Timber Screws
	F	65mm × 12g Hex Head Timber Screws
	G	50mm × 12g Hex Head Steel Tek Screws
22.	Name	Eave lining
	Material	Minimum 4.5 mm thick fibre cement sheet
	Installation	Cut to size and screw fixed to minimum 25 mm deep furring channel
23.	Name	Steel fascia
	Material	Mild steel with a minimum 0.55 BMT
	Installation	Installed onto steel fascia brackets. The brackets are bent to 90°, positioned directly over the face of the Trafalgar Fire BoardEX (Item 1) in the location of the rafter ends, and screw fixed through (Item 1) into the rafter ends using (Item 21E or 21G). The Trafalgar Fire Siderise Spandrel board (Item 2) is then installed around the brackets, and the fascia is clipped into place.
24.	Name	Guttering
	Material	Steel
	Installation	Installed on to steel fascia brackets.

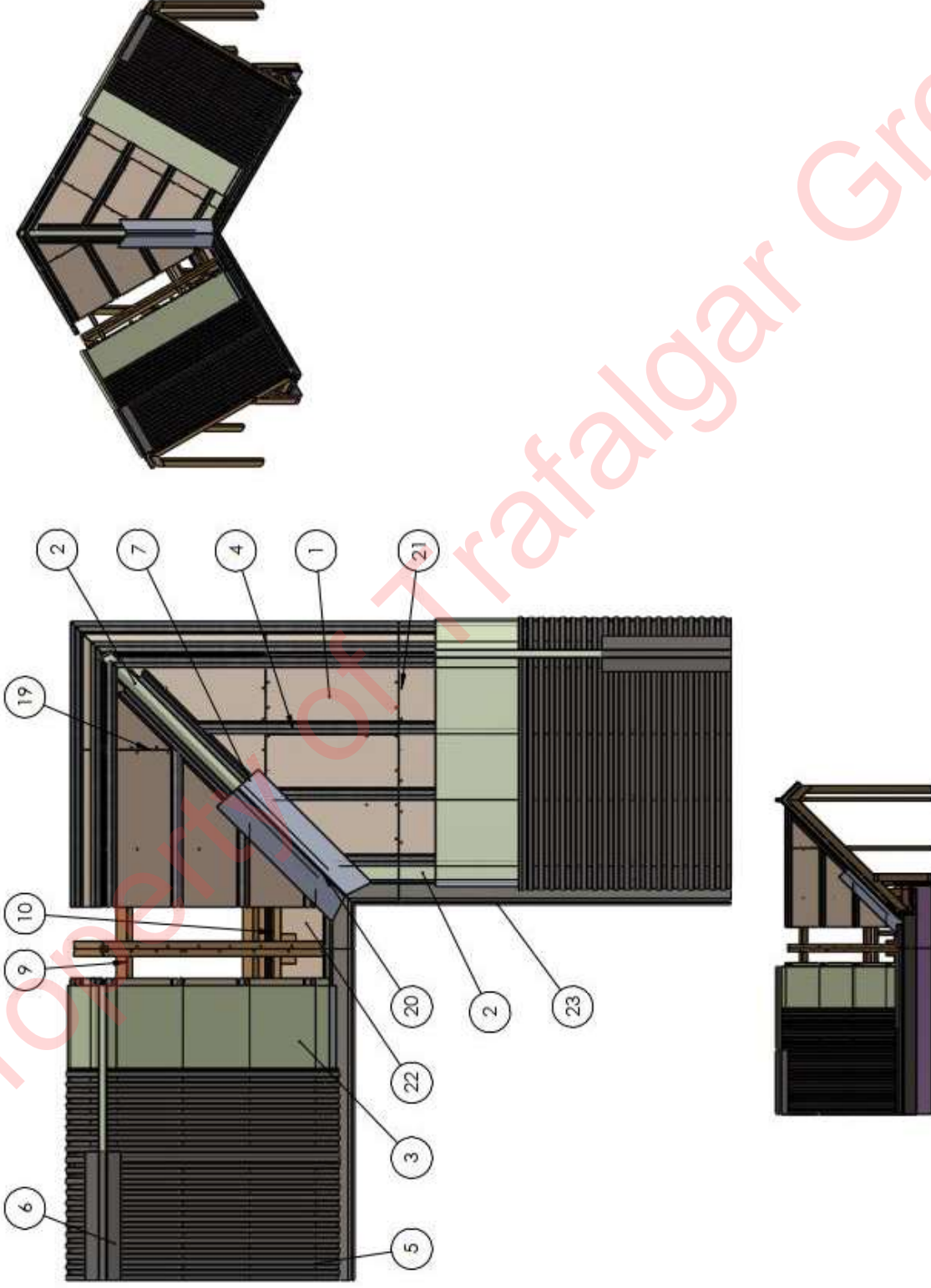

Figure 1 Plan view of metal sheet roof system protected by Trafalgar Fire BAL FZ roof protection elements

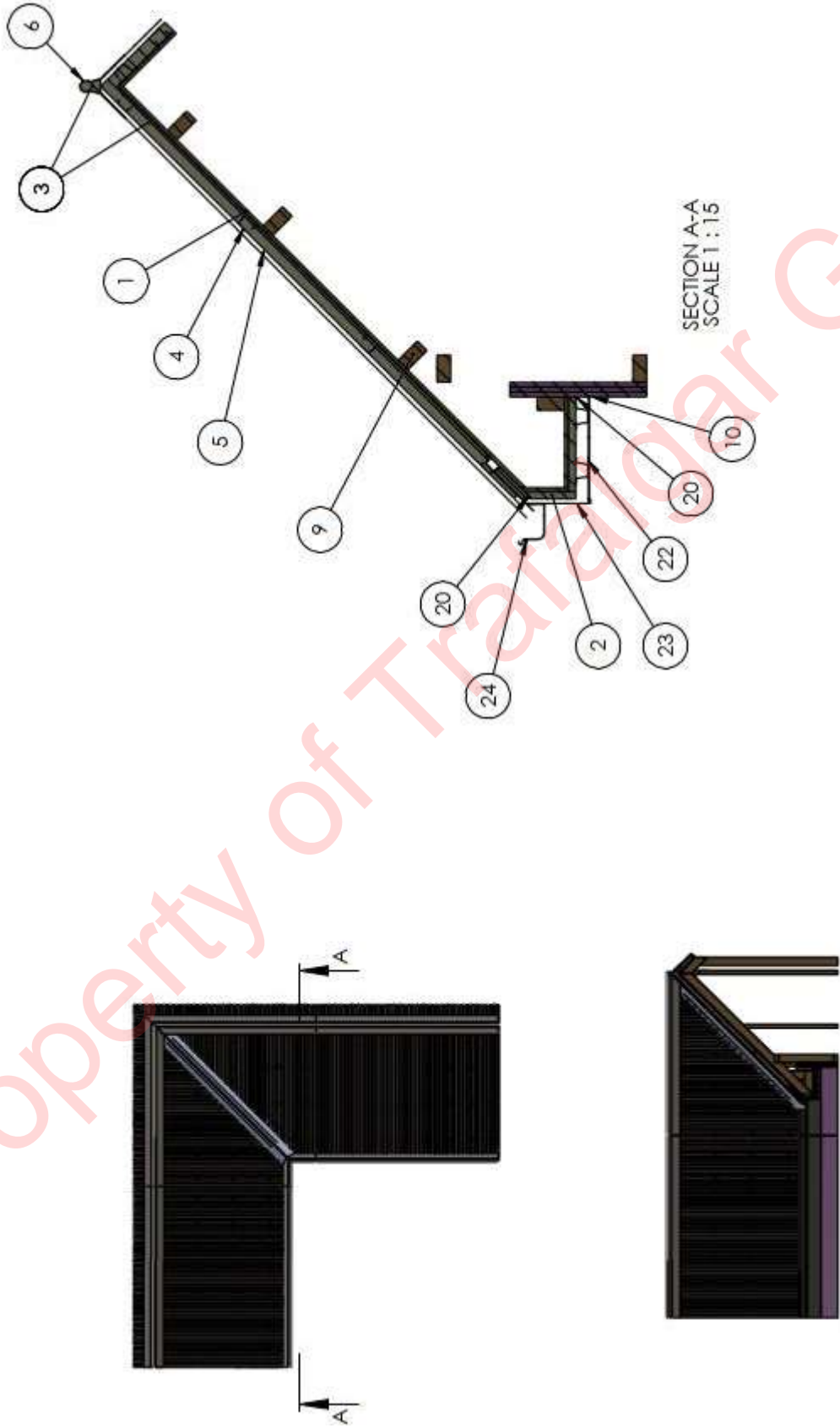

Figure 2 Through section view of metal sheet roof system protected by Trafalgar Fire BAL FZ roof protection elements

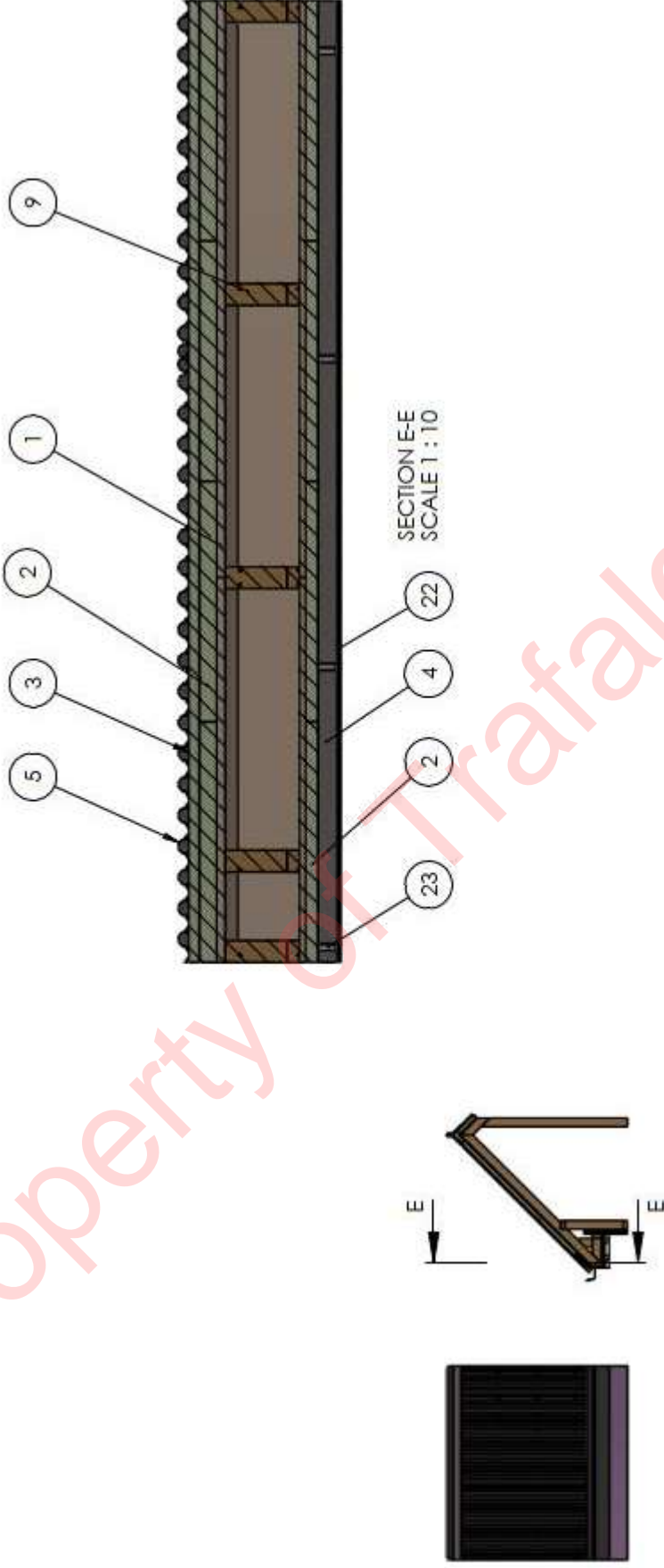

Figure 3 Eave section view of metal sheet roof system protected by Trafalgar Fire BAL FZ roof protection elements

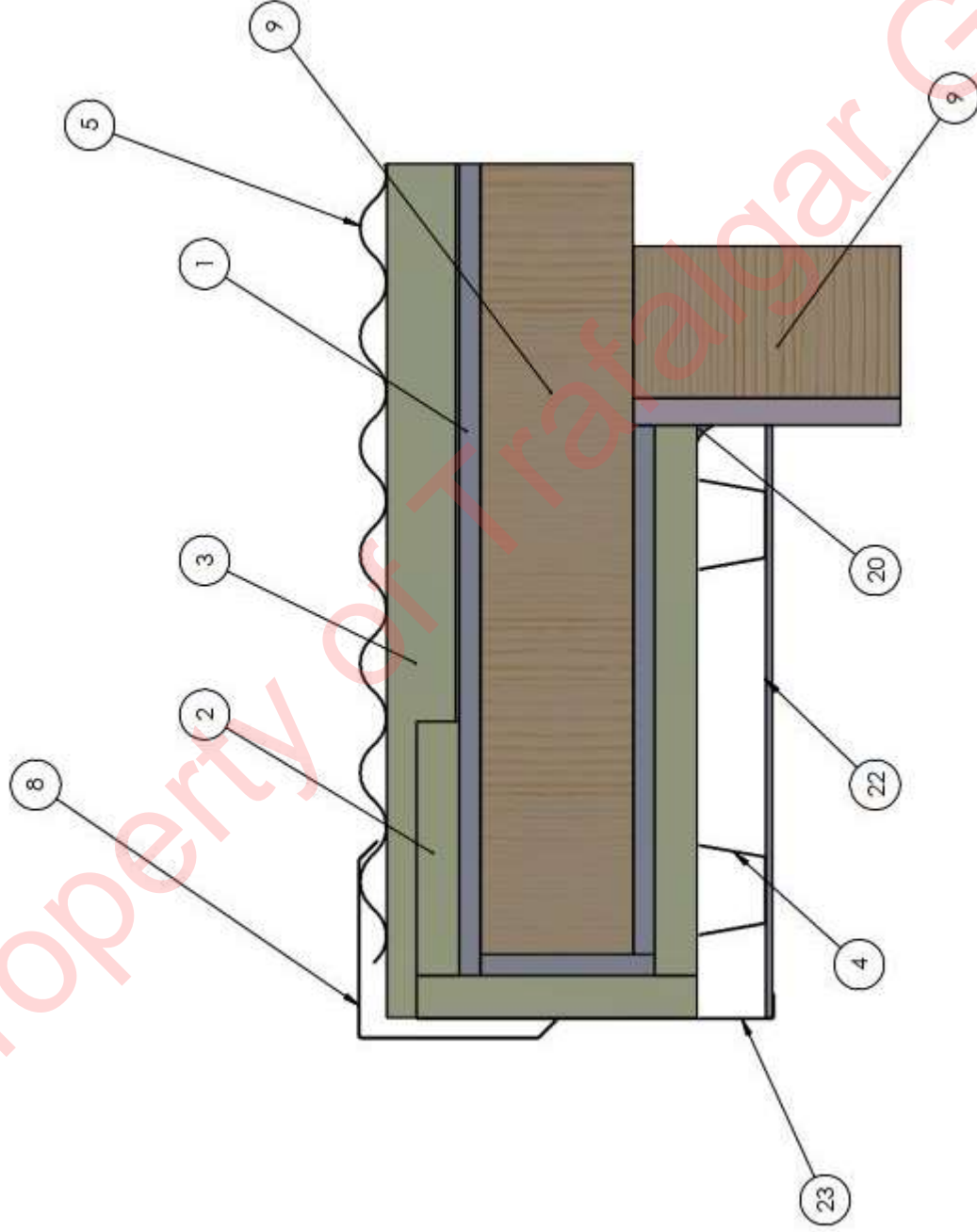

Figure 4 Barge & gable section view of metal sheet roof system protected by Trafalgar Fire BAL FZ roof protection elements



Figure 5 Hip and ridge section view of metal sheet roof system protected by Trafalgar Fire BAL FZ roof protection elements



Figure 6 Valley section view of metal sheet roof system protected by Trafalgar Fire BAL FZ roof protection elements

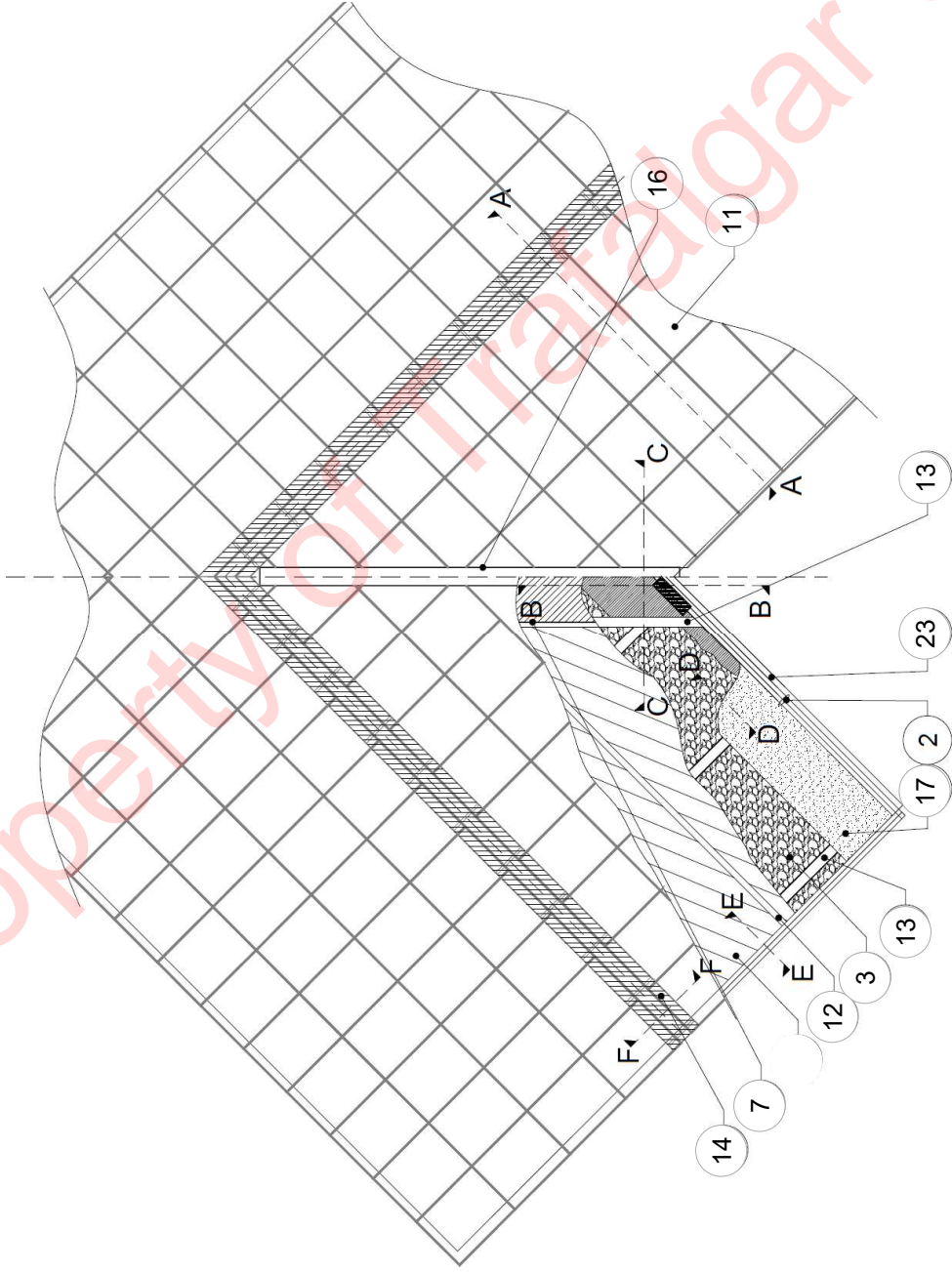

Figure 7 Example of cut away plan of a typical tile roof system showing ridge and valley

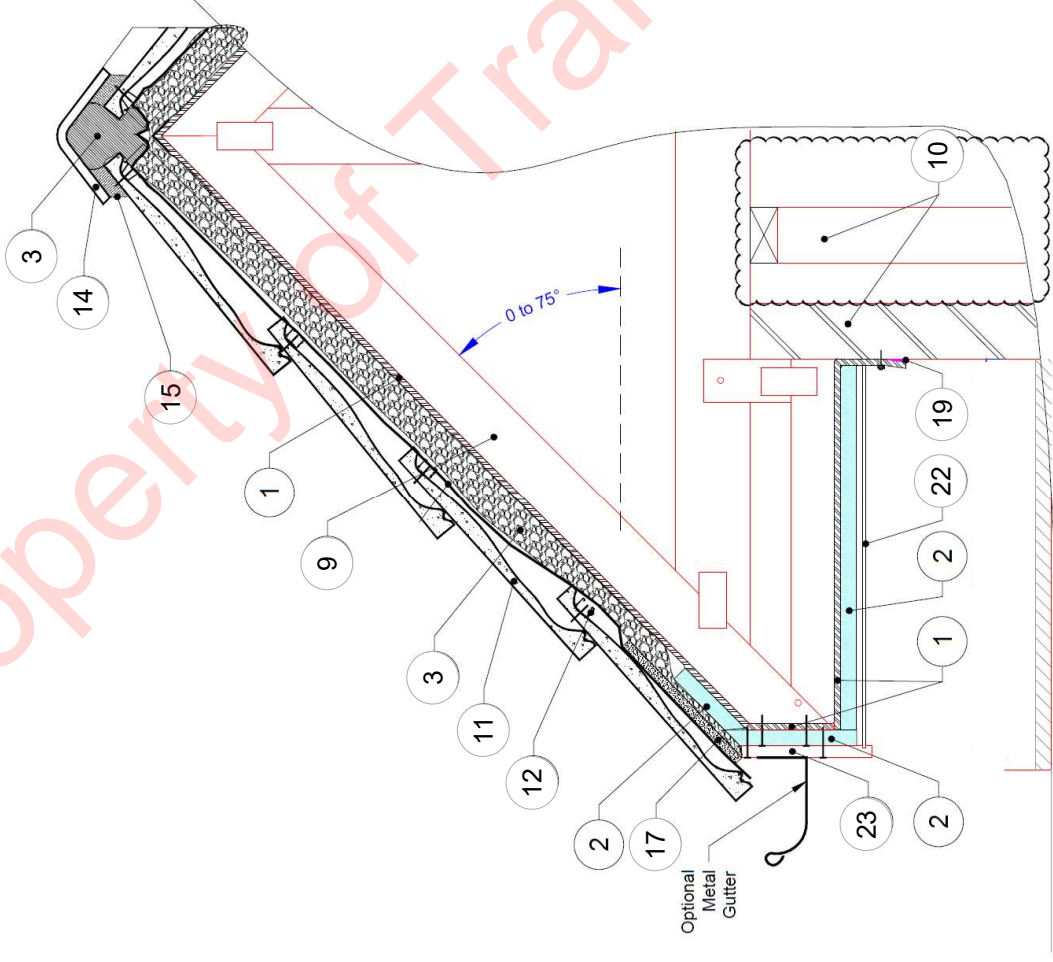

Figure 8 Example of timber frame tile roof system protected by Trafalgar Fire BAL FZ roof protection elements (Section A-A of Figure 7)

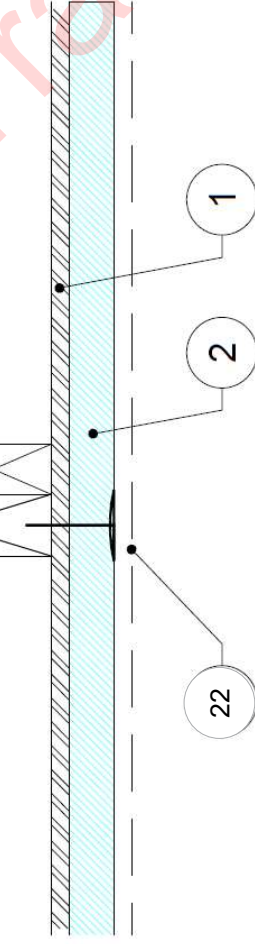
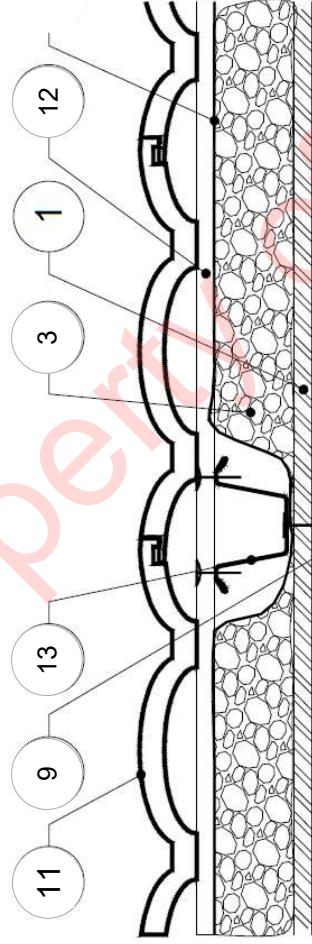

Figure 9 Example of eave detail (Section D-D of Figure 7)

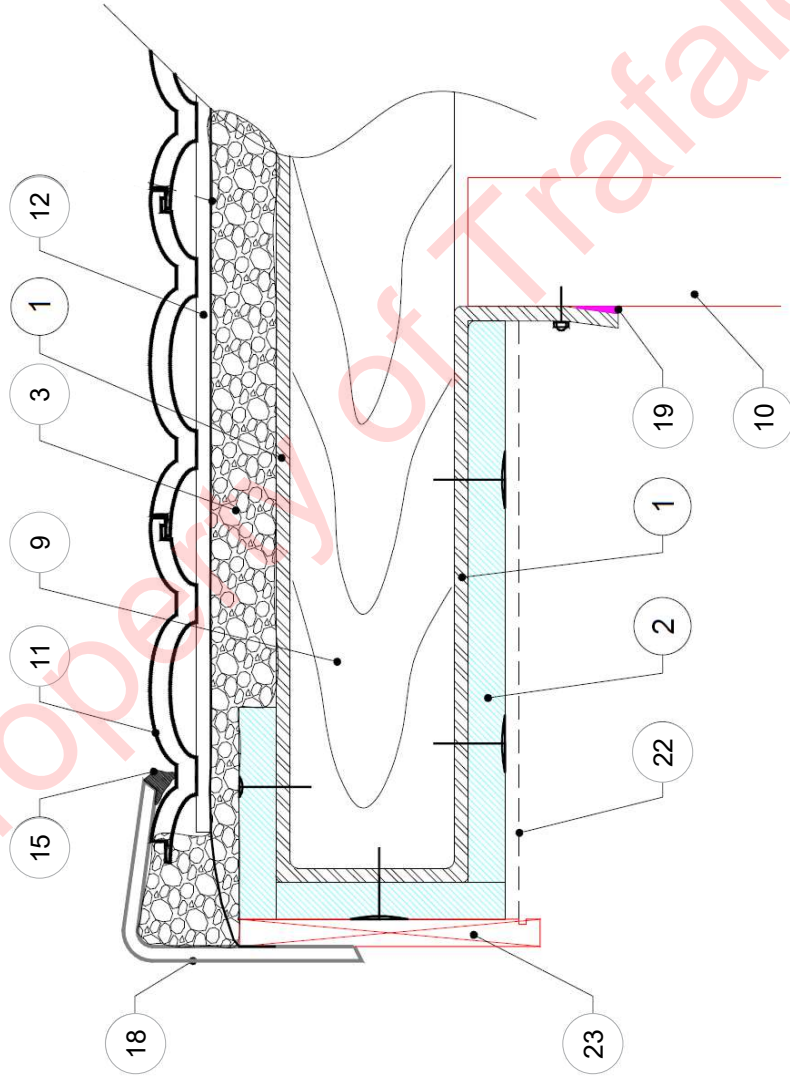

Figure 10 Example of barge and gable detail (Section E-E of Figure 7)

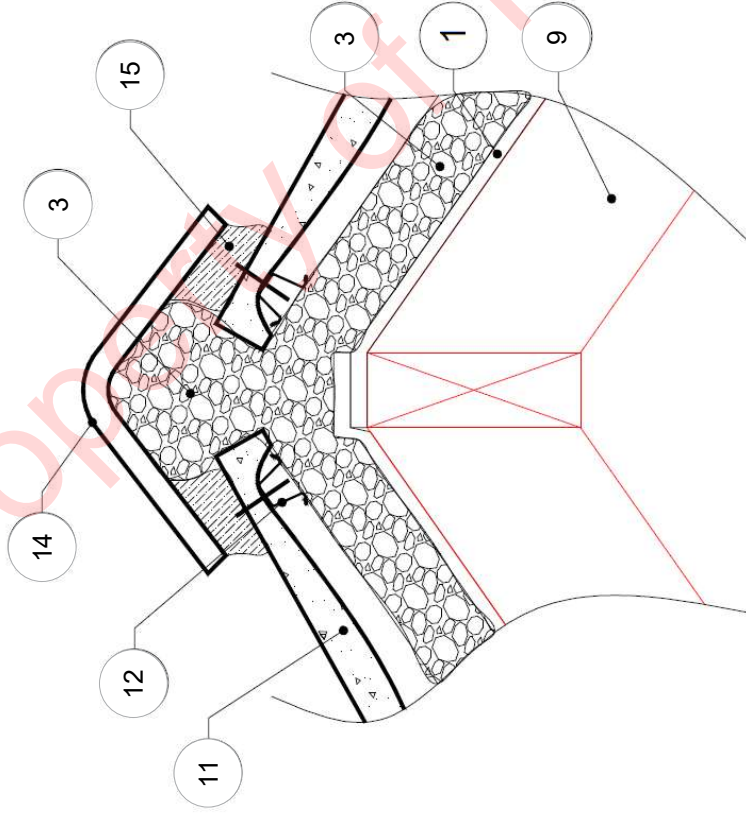

Figure 11 Example of hip detail

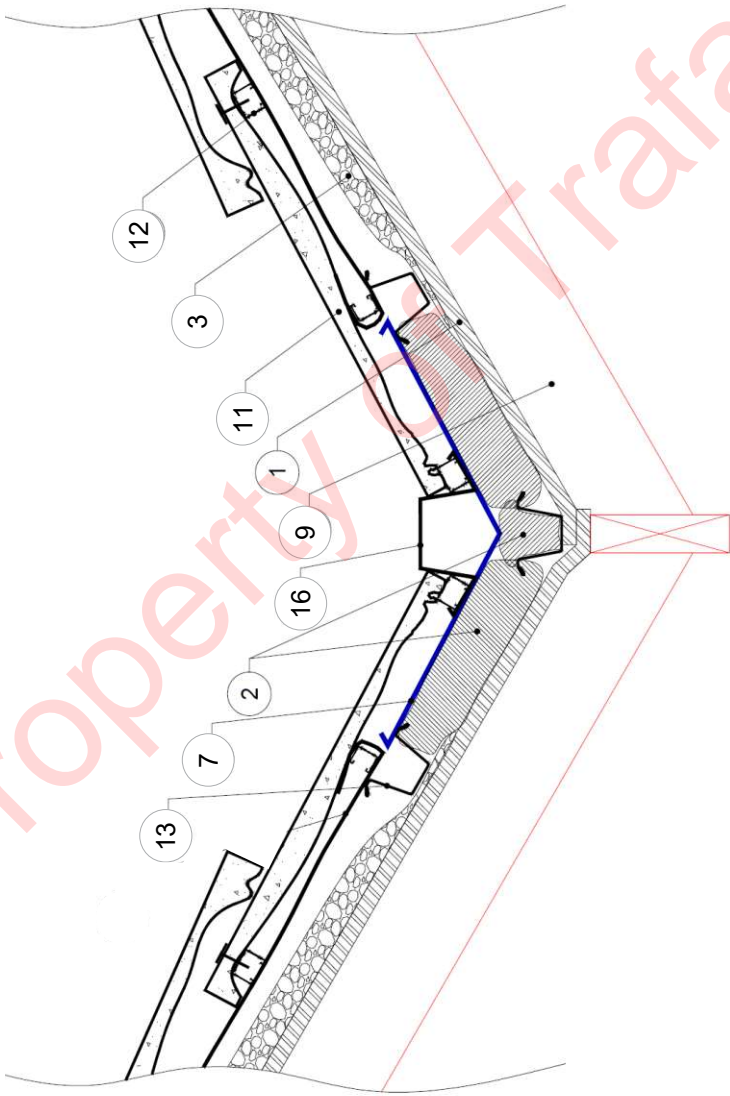

Figure 12 Valley construction (Section C-C of Figure 7)

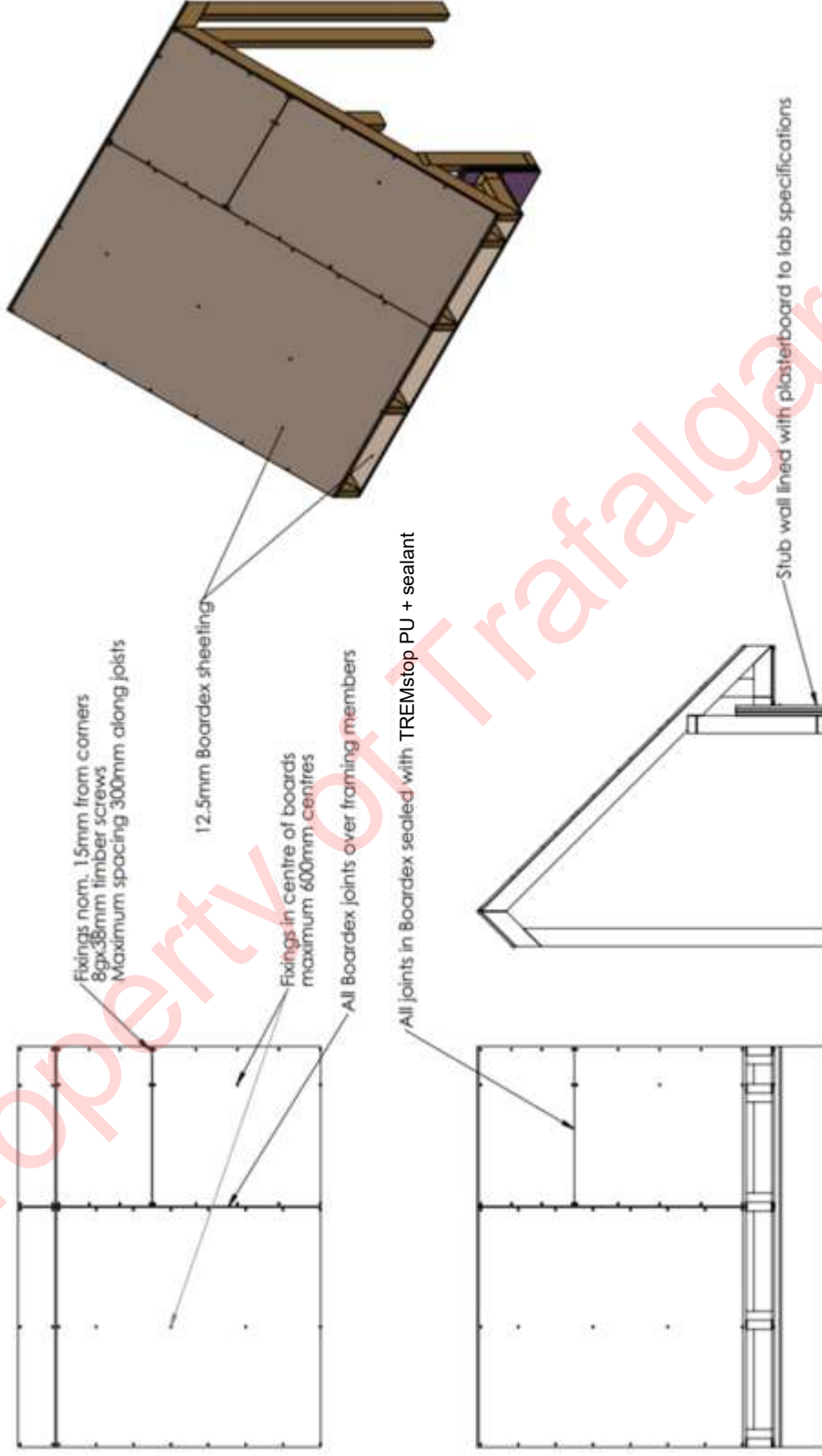

Figure 13 Plan view showing fixing centres for Trafalgar Fire Boardex linings

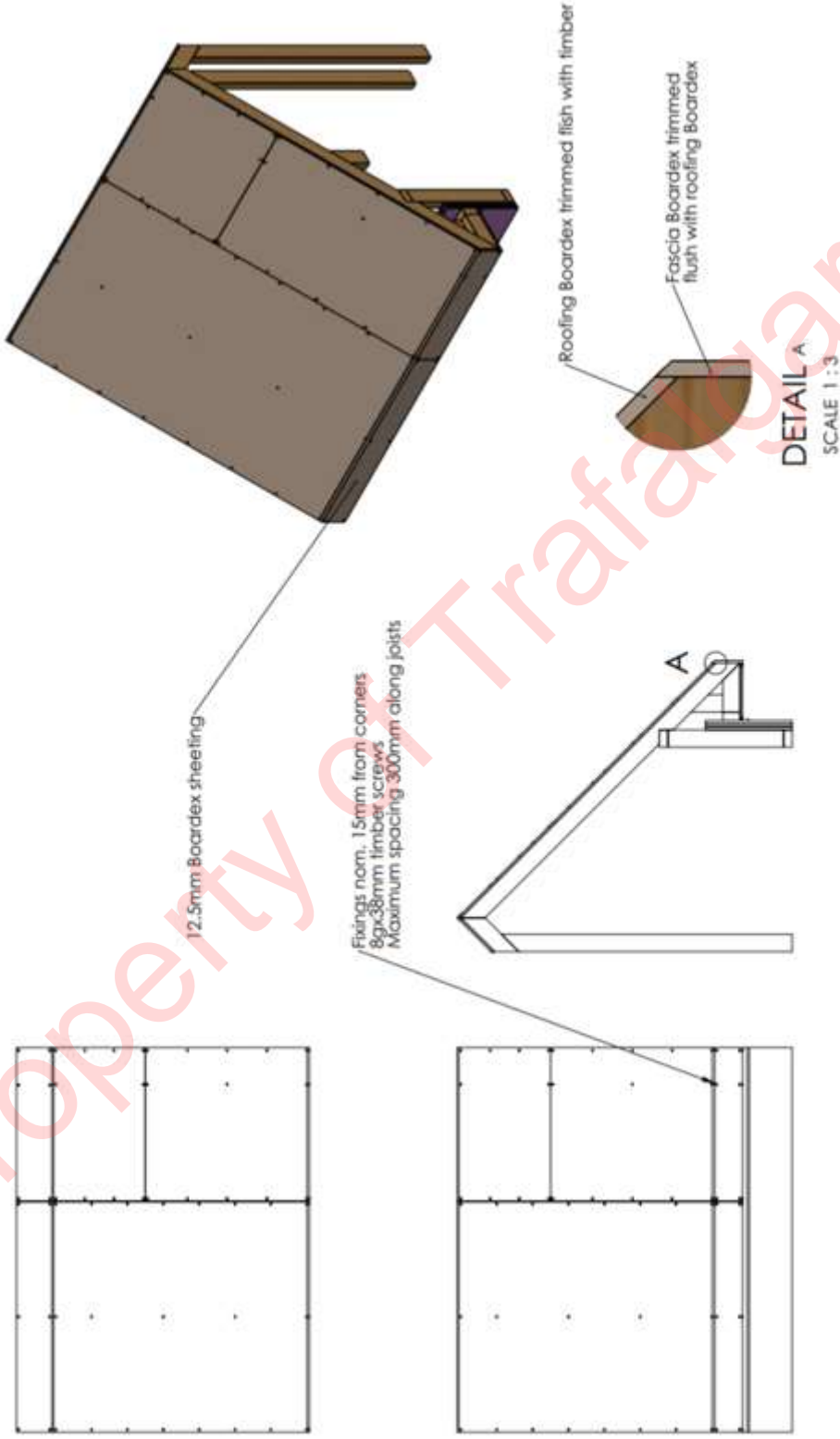

Figure 14 Plan view showing fixing centres for Trafalgar Fire Boardex fascia

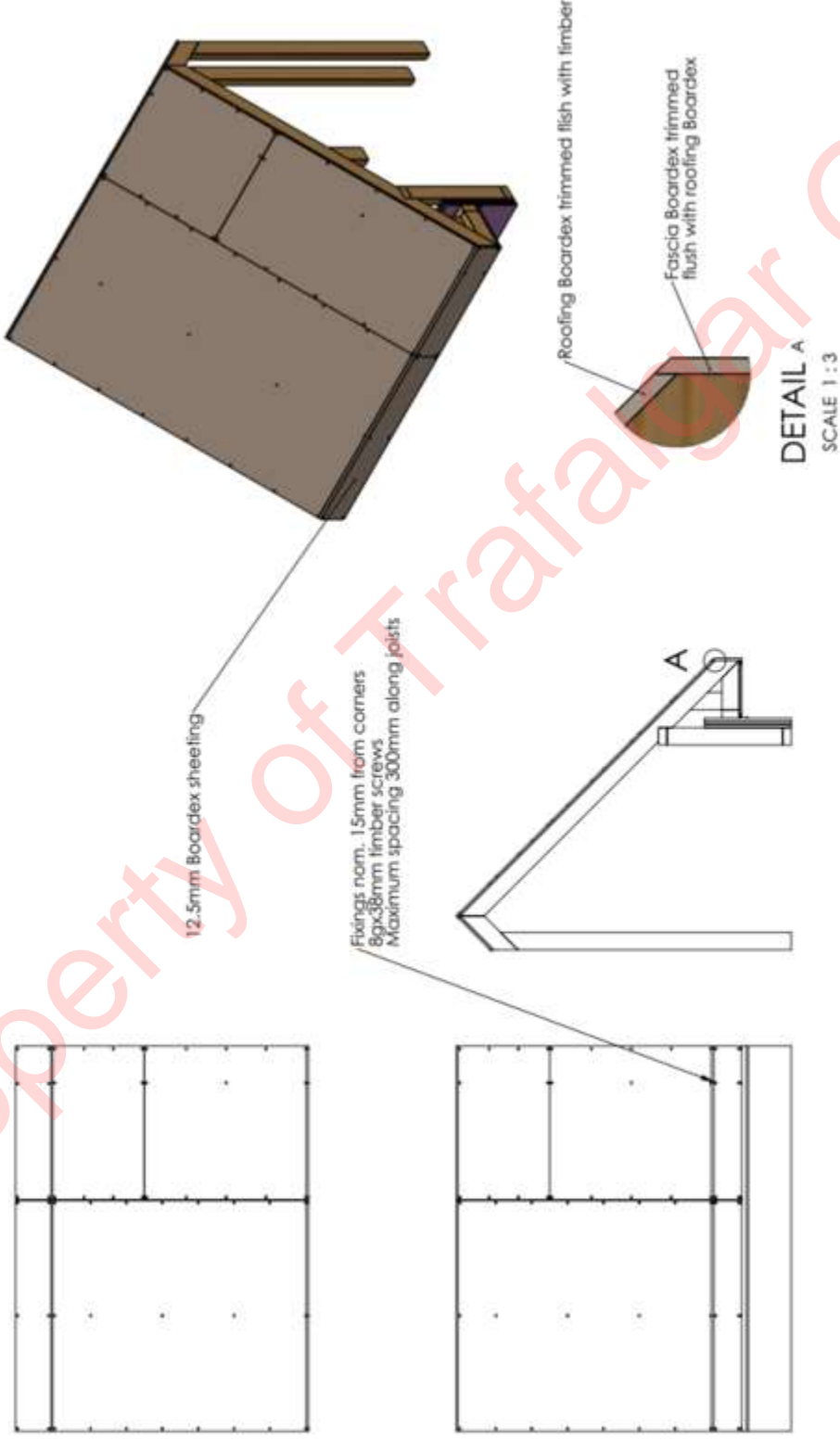

Figure 15 Plan view showing fixing centres for Trafalgar Fire Siderise Spandrel board

Table 6 Schedule of components for assessed vertical orientation of battens

Item	Description
1.	Trafalgar Fire BoardeX
2.	Roof sheeting
3.	4.5 mm thick fibre cement sheet
4.	Gutter bracket zinalume
5.	Barge mould zinalume
6.	Quad gutter zinalume
7.	Fascia zinalume
8.	Ridge capping
9.	Trafalgar TRock Insulation blanket
10.	Trafalgar Fire Siderise Spandrel board
11.	90 mm foil tape (used to tape over joins in Trafalgar TRock Insulation blanket)
12.	Roof frame
13.	Vertical steel roof batten
14.	Top hat
15.	TREMstop PU + sealant
16.	Adjacent wall construction

Property of Trafalgar Group

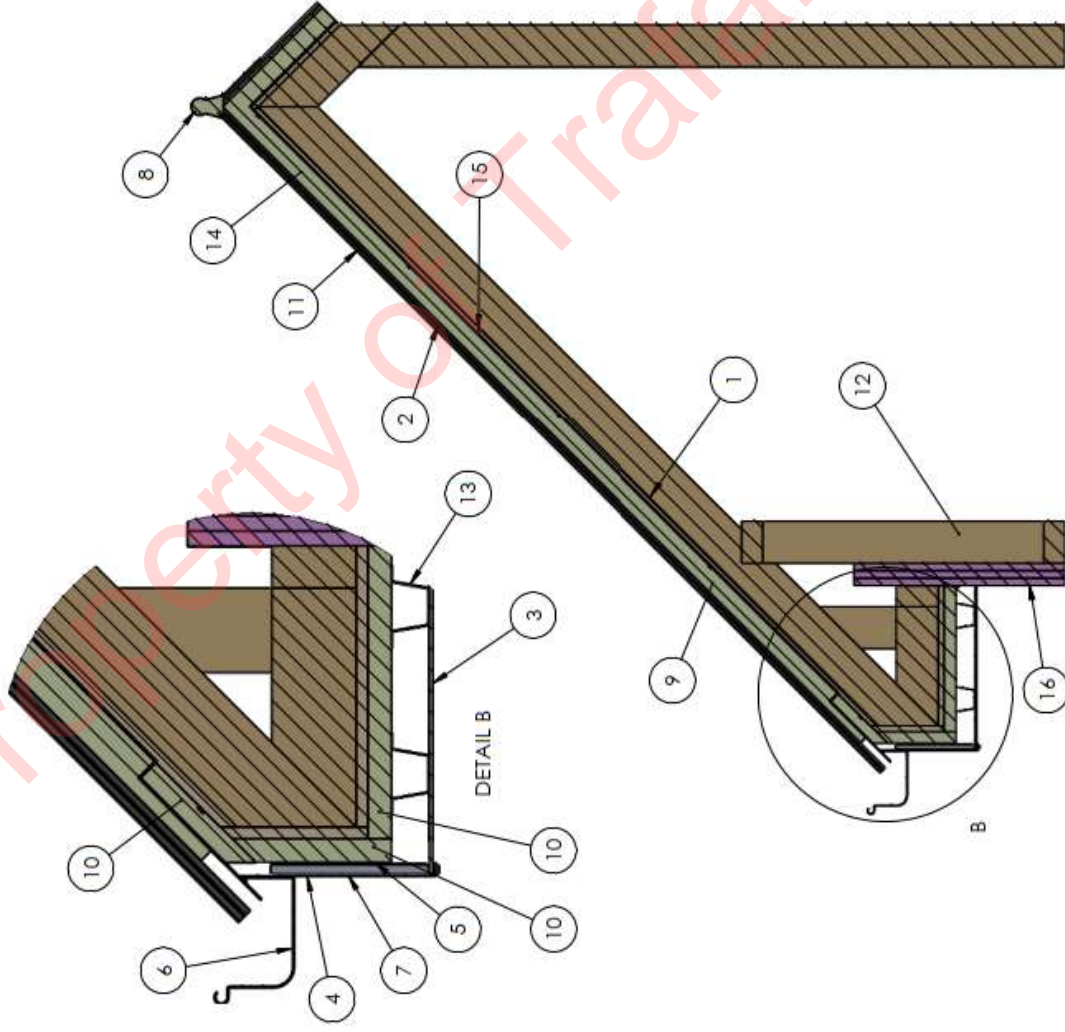

Figure 16 Side view of the metal sheet roof system with vertically installed battens

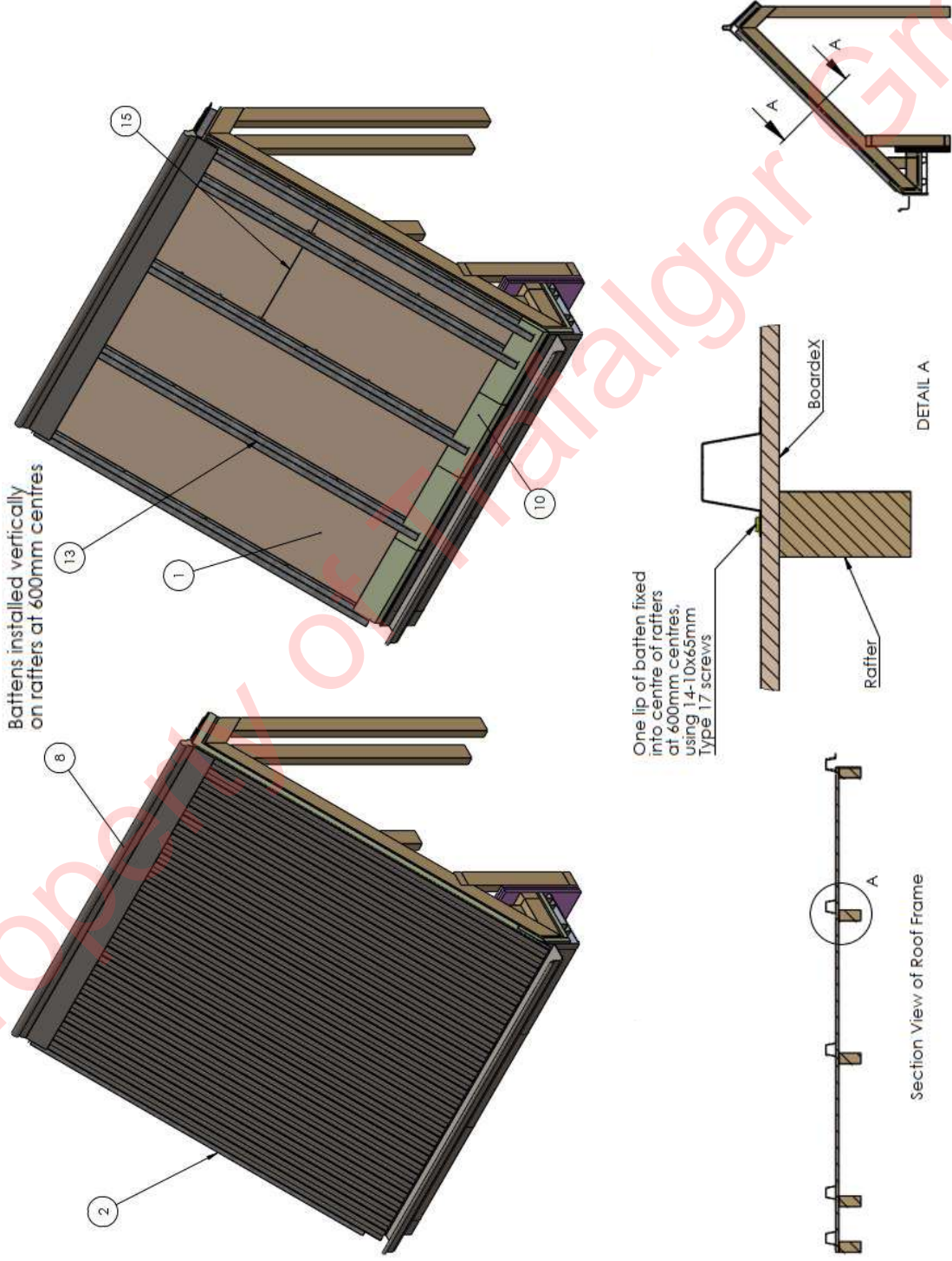

Figure 17 Isometric overview of the metal sheet roof system with vertically installed battens

5. Relevance of AS 1530.8.2:2007 test data with respect to AS 1530.8.2:2018

5.1 Description of variation

The bushfire resistance tests EWFA 2394700.1, EWFA 2368000.1 and EWFA 2398800.1 were conducted in accordance with AS 1530.8.2:2007, which differs from AS 1530.8.2:2018. The effect these differences have on bushfire performance of the referenced test specimens is discussed below.

5.2 Methodology

The method of assessment used is summarised in Table 7.

Table 7 Method of assessment

Assessment method	
Level of complexity	Intermediate assessment
Type of assessment	Comparative

5.3 Assessment

5.3.1 General

In terms of roof systems, the significant modification in AS 1530.8.2:2018, compared to AS 1530.8.2:2007, is the addition of roof valley details in the test specimen.

5.3.2 Specimen conditioning

AS 1530.8.2:2007 specifies that specimen conditioning shall be in accordance with AS 1530.4. AS 1530.4:2005 recommends that it is desirable to maintain the moisture content of timber within the range of 10% and 15%.

AS 1530.8.2:2018 details the conditioning procedures as follows:

Exposed timber product elements

Any timber product element that will be exposed in the test specimen shall be conditioned prior to construction of the specimen so as to approximate the moisture content achieved shortly before exposure to the fire front. For the purpose of AS 1530.8.2:2018, that means:

- Exposed timber elements shall be conditioned to a moisture content of $11 \pm 1.0\%$ on the day of test, and
- The moisture content shall be determined in accordance with AS/NZS 1080.1:2012¹⁰.

Other materials

Other materials shall be conditioned in an environment with an average temperature of $25 \pm 2^\circ\text{C}$ and an average relative humidity (RH) of $45 \pm 5\%$ for a period of at least 1 week prior to the fire test.

Elements with applied coatings or chemical treatments that may improve the fire performance

For elements with applied coatings or chemical treatments that may improve the fire performance, where the specimen meets the items below, there are no additional conditioning requirements prior to testing in accordance with AS 1530.8.2:2018:

- The specimen is intended for applications deemed by Appendix F of AS 3959 as not protected from the weather and

¹⁰ Standards Australia and Standards New Zealand, 2012, Timber - Methods of test, Method 1: Moisture content, AS/NZS 1080.1:2012, Standards Australia, NSW.

- It includes external parts of the specimen that are made from materials that have been impregnated with fire-retardant chemicals or include the application of a fire-retardant or fire protective coating system and
- Tests undertaken in accordance with Appendix B produce a performance ratio for TIGRA_{0.2MJ} and MAHRE between 0.8 and 1.2.
- In conclusion, the moisture levels recommended by AS 1530.8.2:2007 and AS 1530.8.2:2018 are not appreciably different.

5.3.3 Instrumentation

In AS 1530.8.2:2007, the roof specimen thermocouples used to measure non-fire-side temperatures of the specimen and internal surface temperatures shall comply with AS 1530.4. The internal temperature thermocouples shall be fixed to the underside of the external roof lining above the sarking, unless the sarking or lining is non-combustible, in which case the thermocouples shall be fixed to the internal surface of the lining/sarking.

In AS 1530.8.2:2018, the roof specimen thermocouples used to measure non-fire-side temperatures of the specimen and internal surface temperatures shall conform to AS 1530.4. The internal temperature thermocouples shall be fixed at the following locations:

- To the underside of the external roof lining above the sarking. Where the sarking or lining is non-combustible, thermocouples shall be fixed to the internal surface of the lining/sarking.
- Five equally spaced on the internal surface within the roof space enclosure.
- On the underside of the valley gutter, where present.
- At any other location on the internal surface within the roof space enclosure that the laboratory considers may get hot during testing.
- The positioning of the non-fire side and internal thermocouples specified by AS 1530.8.2:2007 and AS 1530.8.2:2018 are not appreciably different.

5.3.4 Furnace temperature and pressure

Note: The roof system is exposed to the standard heating regime of AS 1530.4 during the first 30 minutes of the total test duration of 90 minutes. The control of the furnace shall be in accordance with the requirements of AS 1530.4.

The specifications for furnace thermocouples in AS 1530.4:2014 are the same as those specified in AS 1530.4:2005. The specified furnace temperature in AS 1530.4:2005 and AS 1530.4:2014 follows the same trend. The furnace pressure conditions in AS 1530.4:2005 and AS 1530.4:2014 are not appreciably different. The parameters outlining the accuracy of control of the furnace pressure in AS 1530.4:2014 and AS 1530.4:2005 are not appreciably different.

For horizontal separating elements, AS 1530.4:2014 and AS 1530.4:2005 specify that a pressure of 20 ± 3 Pa shall be maintained in the horizontal plane, 100 ± 10 mm below the underside of the supporting construction.

5.4 Conclusion

The fire resistance tests EWFA 2394700.1, EWFA 2368000.1 and EWFA 2398800.1 were conducted in accordance with AS 1530.8.2:2007. The minor differences in specimen conditioning and instrumentation are not expected to detrimentally affect the bushfire performance as the specimen size and orientation are the same in both AS 1530.8.2:2007 and AS 1530.8.2:2018.

The above discussion in section 5.3 demonstrates that the bushfire performance and BAL achieved in accordance with AS 1530.8.2:2007 can be conservatively applicable to the same test specimen in accordance with AS 1530.8.2:2018.

6. Assessment of metal sheet roof system

6.1 Description of variation

This assessment was undertaken to determine the expected bushfire performance of the system with the proposed variations based on the tests referenced in Appendix B in accordance with AS 1530.8.2:2018.

The variations to the tested systems are:

- Roofing finish be Colorbond® or Zinalume® in lieu of the roofing and ridge capping colour or finish tested.
- Various Colorbond/Zinalume profiles with minimum 0.42 BMT Steel.
- Various Steel roof sheet profiles with minimum 0.42 BMT Steel.
- KLIP-LOK Hi-Strength profiles with minimum 0.42 BMT Steel.
- Roofing finish to be 0.6 mm or 0.42 mm thick.
- Framing may be trusses or rafters.
- Roof framing may be light gauge steel or timber, as tested.
- Truss or rafter spacing maximum 600 mm as tested, safe span of battens and framing must be checked by others.
- Barge and gable detail.
- Metal fascia board.
- Typical hip detail.
- Ridge capping scribed or un-scribed.
- Trafalgar Fire BoardeX may be fixed to framing with 38 mm screws in lieu of staples, as tested.
- Trafalgar Fire BoardeX may be either 15 mm thick or 12.5 mm.
- Inclusion of valley details as tested in BWA 2394700.1, except valley backed with Trafalgar Fire BoardeX and 25 mm Siderise Spandrel Board as tested in FRT220335 R1.0.
- The top hats can be installed vertically on top of Trafalgar Fire BoardeX

6.2 Methodology

The method of assessment used is summarised in Table 8.

Table 8 Method of assessment

Assessment method	
Level of complexity	Intermediate assessment
Type of assessment	Qualitative and comparative

6.3 Assessment

6.3.1 Finish of sheet roof components

It is proposed that the finish of sheet roofing components would be Colorbond® of any colour or Zinalume®. Both Colorbond® and Zinalume® are registered trademarks of BlueScope Steel Limited. Colorbond is a pre-painted steel roofing material made from a Zinalume core and coated with Aluminium-Zinc-Magnesium alloy. Zinalume® steel roofing is an Aluminium-Zinc-Magnesium alloy coated steel. In conclusion, both of these roofing materials have metal alloy coatings with a melting point ranging from 400 – 600 °C.

The roof sheeting temperatures measured in FRT220335 R1.0 reached around 700 °C within the first 15 minutes of test and up to around 800 °C at 30 minutes. Therefore, both coatings are expected to be either consumed or melted during the early stages of testing. The potential for the coating to affect the results of the test is therefore limited to the first few minutes. During this time, the radiation levels have not reached significant levels. As radiation is the dominant mode of heat transfer from the furnace to the specimen for the first 30 minutes of the test, it is considered that any minor effects caused by applied coatings would occur before the specimen is exposed to extreme radiation levels.

Based on the above discussion, it is considered that the finish of the metal sheeting and components will not have a significant effect on the results. In the absence of any apparent risk presented in the results when tested to AS 1530.8.2:2018, the proposed variation in coating is positively assessed for BAL FZ.

6.3.2 Various steel roof sheet profiles

It is proposed that various Colorbond/Zincalume, steel roof sheet and KLIP-LOK700 HI-Strength sheet profiles with minimum 0.42 BMT steel will be used instead of the CUSTOM ORB® Steel by BlueScope as tested in FRT220335 R1.0.

The proposed profiles are considered similar to the CUSTOM ORB® steel sheet profiles, provided that they are manufactured in accordance with AS 1445:2013¹¹ (Hot-dipped zinc-coated, aluminium/zinc-coated or aluminium/zinc/magnesium-coated steel sheet — 76 mm pitch corrugated). The tested steel roof sheet profile did not promote any failure in accordance with AS 1530.8.2:2018, and it is expected that a product with a similar base metal thickness or higher installed in the same configuration as tested and mentioned in item 13 of Table 5 will not introduce any detrimental impact to the fire-resistant performance.

Based on the above discussion and in the absence of any adverse risk from the proposed construction, the proposed construction can be positively assessed for BAL FZ in accordance with AS 1530.8.2:2018.

6.3.3 Sheet roofing thickness

It is proposed that the metal thickness of sheet roofing components such as roofing and flashing may be increased from 0.42 mm, as tested, up to 0.6 mm.

Increasing the thickness of metal components has a key effect of slightly reducing the heating rate of the sheeting. As a result, it will take a longer time for the sheeting to reach its peak temperature. This is generally considered a positive outcome. However, it will also slightly decrease the rate of cooling of the sheeting at the conclusion of the heating phase. With reference to the test FRT220335 R1.0, the average roofing temperature generally followed the furnace heating curve, lagging it by around 40 °C for the duration of the test. At 30 minutes, the average sheeting temperature was approximately 802 °C, while the furnace was approximately 840 °C. It is expected that the increase in thickness of the sheeting will slow the heating rate or increase the difference in sheeting temperatures relative to the furnace temperatures, as the furnace temperature rises quickly in the first thirty minutes of exposure.

In addition, the increase in sheeting thickness is expected to increase the heat capacity of the sheeting, potentially slightly decreasing the cooling rate. When the specimen lined with 0.42 mm steel sheeting was removed from the heating, the sheeting temperature dropped to 60 °C in 30 minutes in EWFA 2406300.1. It is expected that for the 0.6 mm sheeting, the peak sheeting temperatures will drop, and the cool down period could be extended by up to 43% or up to 43 minutes. When this is considered with respect to the effect on the total heat capacity of the system, including the insulation between the roof sheeting, the effect of minor extra heating is considered a minor influence only. Moreover, the effect of a slower cooling period may be offset by lower peak temperatures during the heating phase, further diminishing the net difference in exposure of the remainder of the specimen.

Based on the above discussion, it is considered that the increase in the base metal thickness from 0.42 mm to 0.6 mm will not have a detrimental effect on the performance of the proposed construction. In the absence of any apparent risk presented in the results when tested to

¹¹ Standards Australia, 2013, Hot-dipped zinc-coated, aluminium/zinc-coated or aluminium/zinc/magnesium-coated steel sheet — 76 mm pitch corrugated, AS 1445:2013, Standards Australia, NSW.

AS 1530.8.2:2018, the proposed variation in sheeting and component thickness is positively assessed for BAL FZ.

6.3.4 Steel roof framing

It is proposed to construct the roof frame with light gauge steel instead of timber, as tested in FRT220335 R1.0.

The proposed steel framing, unlike timber framing, is a good thermal conductor and can transfer heat away from hot spots rather than allow heat to build up. According to FRT220335 R1.0, the maximum temperature measured on the steel nogging was only 94 °C (TC 027). At this low-temperature range, a steel structure is expected to maintain its ambient temperature mechanical properties; hence, its structural stability and load-bearing capacity are not expected to be compromised.

Please note that the framing and safe spans of battens must be sized and designed by a professional structural engineer according to relevant standards, considering design load combinations at ambient and elevated temperatures.

Based on the above, it is considered that the structural adequacy of the proposed steel framing will not be detrimentally affected. In the absence of any apparent risk presented in the results when tested to AS 1530.8.2:2018, the proposed variation in roof framing is positively assessed for BAL FZ.

6.3.5 Roof framing spacing and sizing

For the frame of the roof system, it is proposed to maintain the truss or rafter spacing at a maximum of 600 mm as tested in FRT220335 R1.0.

In the referenced test, the specimen consisted of a series of timber roof rafters at approximately 600 mm centres made from 90 × 35 mm elements. Hence, it is recommended to maintain a maximum spacing of 600 mm between two rafters or trusses when constructing the framing of the proposed steel sheet roof system.

The 40 mm roof battens were fixed horizontally to the top of the Trafalgar Fire Board[®] panels at 600 mm centres, using 65 mm timber screws at rafter centres. The roof battens are not primary structural members, and slight distortion of them would not lead to significant structural consequences or significantly affect the performance of the remainder of the system.

The framing and safe spans of battens must be sized and designed by a professional structural engineer according to relevant standards, considering design load combinations at ambient and elevated temperatures.

Based on the above, it is considered that the performance of the proposed construction is not expected to have a detrimental effect when incorporating the proposed steel framing in accordance with AS 1530.8.2:2018.

6.3.6 Barge or gable detail

It is proposed to install the barge or gable detail of the steel sheet roof system as shown in Figure 4.

The key aspect of the protection of the barge detail is the Trafalgar TRock Insulation blanket laid directly over the top of the Trafalgar Fire Siderise Spandrel Board at the edge of the roof. The rockwool insulation is expected to prevent the free flow of hot gases from the furnace as it is compressed against the edges of the roof sheeting to prevent gap formation at this location.

The proposed detail is a slight variation on the eaves detail tested in FRT220335 R1.0. In the tested specimen, the roof lining materials were not significantly hotter near the eaves of the fascia and the junction was effective at preventing hot gasses from entering the cavity at this location. In the proposed detail, the compressed rockwool arrangement is expected to prevent air flow into the cavity, thereby preventing embers from entering the roof cavity. By eliminating this air path with a material that is resistant to fire provides further confidence in the effectiveness of the details at this location.

Based on the above discussion, it is considered that the proposed barge or gable detail will not have a detrimental effect on the performance of the proposed construction. In the absence of any apparent risk presented in the results when tested to AS 1530.8.2:2018, the proposed barge or gable detail is positively assessed for BAL FZ.

6.3.7 Metal fascia board

It is proposed to install a metal fascia board for the sheet roof system.

It is verified that the tested roof system in FRT220335 R1.0 included a metal fascia. When tested, the roof system achieved a BAL FZ rating with a safety margin, and the maximum internal temperature measured on the fascia was 788 °C at 30 minutes. The fascia temperature dropped to 80 °C at 60 minutes after the specimen was removed from heating, which meets the performance criteria specified in AS 1530.8.2:2018. These results indicate that the roof system demonstrated effective fire resistance and thermal performance.

Based on the above, it is considered that the inclusion of the metal fascia will not detrimentally affect the bushfire performance of the sheet roof system. In the absence of any apparent risk presented in the results, the proposed metal fascia is positively assessed for BAL FZ in accordance with AS 1530.8.2:2018.

6.3.8 Hip and ridge detail

It is proposed that the hip and ridge details of the steel sheet roof system be as shown in Figure 5. In the proposed detail, Trafalgar TRock Insulation blanket is laid directly over the top of the steel top hats and the Trafalgar Fire BoardeX panel with the foil face facing down, ensuring that the foil tongues sit under each abutting roll and continue into the gutter/valley by a minimum of 75 mm. An additional layer of insulation is installed under the ridge capping, ensuring that it is positioned at least 40 mm back from the bottom of the two lips of the ridge capping to prevent wicking.

It is confirmed that the proposed hip and ridge detail is as tested in FRT220335 R1.0 and is therefore positively assessed for BAL FZ if tested in accordance with AS 1530.8.2:2018.

6.3.9 Scribing of ridge and hip capping for sheet roofing

It is proposed that the ridge capping may be scribed to follow the profile of the sheet or be un-scribed as tested.

The key aspect of the protection of the ridge and hip detail is the Trafalgar TRock Insulation blanket located along with the corrugations of the sheeting at the edges of the roof sheeting. The insulation material being compressed to a certain degree prevents air flow into the cavity and the formation of gaps. Scribing the ridge capping into the corrugations of the roofing will further reduce the risk of forming any gaps.

As discussed in 6.3.8, the proposed hip and ridge details are as tested in FRT220335 R1.0. Therefore, in the absence of any apparent risks, the proposed variation of scribing of the ridge and hip flashing details is positively assessed for BAL FZ in accordance with AS 1530.8.2:2018.

6.3.10 Fixing of Trafalgar Fire BoardeX panel to framing

It is proposed to use screws to fix the Trafalgar Fire BoardeX panel to the framing instead of staples, as tested in FRT220335 R1.0.

In the proposed system, the Trafalgar Fire BoardeX panel is installed directly over framing to completely encapsulate the frame of the roof, fascia, and eave elevations, ensuring that all joints and abutments finish on either the frame or noggins (Figure 13 and Figure 14). A minimum 6 mm bead of TREMstop PU+ sealant is applied around the perimeter of the boards and the boards are tightly butted up to each other at the joints and abutments, ensuring there are no gaps.

The Trafalgar Fire BoardeX panel is affixed to the roof frame using either staples (only for timber frame) or screws, ensuring a tight seal that hinders air infiltration into the cavity and eliminates the formation of any gaps. It is expected that using 38 mm drywall needlepoint or self-drilling screws to fix the Trafalgar Fire BoardeX board to the timber or steel frame, respectively, will not introduce any detrimental impact on the overall fire performance of the roof system. Therefore, in the absence of any apparent risks, the proposed variation is positively assessed for BAL FZ in accordance with AS 1530.8.2:2018.

6.3.11 Thickness of Trafalgar Fire BoardeX panel

It is proposed that the thickness of the Trafalgar Fire BoardeX panel may be 15 mm.

As mentioned in 6.3.10, the Trafalgar Fire BoardEX panel is installed directly over framing to completely encapsulate the frame of the roof, fascia, and eave elevations (Figure 13 and Figure 14). The replacement of 12.5 mm thick board with a 15 mm thick board is expected to provide further resistance to radiant heat transfer. On that basis, it is expected that the proposed construction will perform at least similar to or better than the tested specimen under similar bushfire conditions.

Based on the above discussion and in the absence of any adverse risk, the proposed variation can be positively assessed for BAL FZ in accordance with AS 1530.8.2:2018.

6.3.12 Proposed valley details

It is proposed to include valley details as tested in BWA 2394700.1, except valleys backed with Trafalgar Fire BoardEX and 25 mm thick Siderise Spandrel Board as tested in FRT220335 R1.0. The key aspect of the protection of the valley detail is the compressed Trafalgar TRock Insulation blanket at the edge of the valley in conjunction with Siderise insulation board and Trafalgar Fire BoardEX board under the valley gutter.

In the referenced test, BWA 2394700.1, the specimen consisted of a roof system with a similar rockwool gasket at the edge of the roof sheeting. During testing, it was observed that the temperatures of the roof lining near the valley junction were lower compared to the average temperatures of the roof lining. This indicates that the construction detail at the junction effectively restricted the flow of hot gases into the roof cavity along the valley. It is worth noting that the compressed rockwool gasket not only prevents air from entering the cavity but also acts as a barrier against any embers that might be present. By preventing this air path with a material that is resistant to embers, gives confidence in the effectiveness of the gasket at this location.

Referring to BWA 2394700.1, a fire-resistant valley lining material (16 mm fire grade plasterboard) was placed under the valley gutter to provide insulation to the roof from the direct effect of the fire for the 30-minute exposure period. The tested configuration achieved a rating of BAL FZ with a safety margin. The proposed construction uses a 25 mm thick Trafalgar Fire Siderise Spandrel board instead of the 16 mm thick fire grade plasterboard. With reference to BWA 2394700.1, the eaves construction consisted of a 9 mm lining board placed under a 16 mm fire grade plasterboard. When tested, it achieved a BAL FZ rating with a safety margin, with the roof lining temperatures on the eaves reaching a maximum of 120 °C.

With reference to FRT220335 R1.0, the eaves construction consisted of a 12.5 mm thick Trafalgar Fire BoardEX board placed under a 25 mm thick Trafalgar Fire Siderise Spandrel insulation board. When tested, it successfully demonstrated BAL FZ performance, meeting the performance criteria. This establishes that the tested construction could effectively prevent significant flows of hot gases into the roof cavity.

The proposed construction consists of a steel valley gutter backed with 12.5 mm (or thicker) Trafalgar Fire BoardEX board and 25 mm thick Trafalgar Fire Siderise Spandrel insulation board as shown in Figure 6. Based on the above discussion, it is expected that replacing the 16 mm fire grade plasterboard with Trafalgar Fire BoardEX and Trafalgar Fire Siderise Spandrel insulation board at the valley detail will not introduce any detrimental impact on the bushfire performance of the roof system.

Hence, in the absence of any adverse risk, the proposed variation can be positively assessed for BAL FZ in accordance with AS 1530.8.2:2018.

6.3.13 Vertical battens

It is proposed to optionally install the top hats vertically on top of Trafalgar Fire BoardEX, instead of the horizontal configuration tested in FRT220335 R1.0 as shown in Figure 16 and Figure 17.

In the test, 40 mm roof battens were fixed horizontally to the top of Trafalgar Fire BoardEX panels at 600 mm centres, fixed using 65 mm screws at rafter centres. The roof sheeting was fixed into position, sandwiching the insulation blanket underneath. The roof battens are not primary structural members, and slight distortion of them would not lead to significant structural consequences or significantly affect the performance of the remainder of the system. In the proposed construction, the top hats are positioned vertically, and a single corrugation pattern will run continuously along the top hat. In the tested specimen, roof sheeting with a 77 mm pitch distance was used. Therefore, to maintain the same fixing distance as in the tested specimen, the fixing separations at various locations have been determined, as shown in the Table 9.

Table 9 Proposed fixing centres for attaching steel roof sheeting to top hats

Location	Proposed distance between fixings
Roof sheeting to steel battens (top and bottom of battens)	150 mm
Roof sheeting to steel battens (in the field of the sheeting)	385 mm
Edges of the roof, at locations such as the fascia and hip	150 mm
Roof sheeting with angled cuts such as valleys	75 mm

Based on the above, the proposed variation can be positively assessed for BAL FZ in accordance with AS 1530.8.2:2018, provided that the framing of the roof system is sized and designed by a professional structural engineer according to relevant standards, considering design actions at ambient and elevated temperatures.

6.4 Conclusion

Based on the above discussion, it is considered that the proposed variations to the sheet roof system protected with Trafalgar Fire roof protection system are expected to achieve BAL FZ as shown in Table 10 in accordance with AS 1530.8.2:2018.

Table 10 Variations and assessment outcome for metal sheet roof system

Item	Reference tests	Description	Variations	BAL rating
Metal sheet roof	FRT220335 R1.0 EWFA 2394700.1	FRT220335 R1.0 included a straight section of a metal sheet roof protected with Trafalgar Fire BAL FZ roof protection system tested in accordance with AS 1530.8.2:2018. EWFA 2394700.1 included a valley junction system of a similar metal sheet clad roof system tested in accordance with AS 1530.8.2:2007.	<p>The following variations are to be assessed in accordance with AS 1530.8.2:2018 using the results of the referenced tests:</p> <ul style="list-style-type: none"> The roofing finish can be Colorbond® or Zincolume®. The roof sheet profile can be chosen from various steel sheet profiles such as Colorbond®, Zincolume®, KLIP-LOK Hi-Strength, with a thickness of 0.42 or 0.6 BMT. The roof framing can be constructed using either trusses or rafters made from light gauge steel or timber with a maximum spacing of 600 mm. Inclusion of Metal fascia board Inclusion of barge and gable detail as shown in Figure 4 Inclusion of hip and ridge detail as shown in Figure 5 The ridge capping can be scribed or un-scribed. 12.5 mm or 15 mm thick Trafalgar Fire BoardeX can be fixed to framing with 38 mm screws instead of staples Inclusion of valley details as tested in BWA 2394700.1, except valley backed with Trafalgar Fire BoardeX and 25 mm Siderise Spandrel Board as tested in FRT220335 R1.0 (Figure 6). The top hats can be installed vertically on top of Trafalgar Fire BoardeX (Figure 16 – Figure 17). 	BAL FZ

7. Assessment of concrete or terracotta tile roof system

7.1 Description of variation

This assessment was undertaken to determine the expected bushfire performance of the system with the proposed variations based on the tests referenced in Appendix B in accordance with AS 1530.8.2:2018.

The variations to the tested systems are:

- Roof cladding to be concrete or terracotta tiles, as tested in BWA 23680-00.1 and BWA 23988-00.
- Truss or rafter spacing maximum 600 mm as tested, though safe span of battens and framing shall be designed by others.
- Variation in the profile and mass of the concrete or terracotta roof tiles from 46 kg/m² to 54 kg/m².
- The roof cavity insulation shall be replaced with Trafalgar Fire rockwool insulation with a foil face on the top face, 50 mm thick, with a nominal density of 60 kg/m³.
- Inclusion of typical barge, gable, hip, and valley details.
- Roofing battens to be installed vertically (parallel to roof frame timbers) and incorporate horizontal roof tile battens as tested in BWA 23680-00.1 and BWA 23988-00.

7.2 Methodology

The method of assessment used is summarised in Table 8.

Table 11 Method of assessment

Assessment method	
Level of complexity	Intermediate assessment
Type of assessment	Qualitative and comparative

7.3 Assessment

7.3.1 Concrete or terracotta tiles as roof cladding

It is proposed to install concrete or terracotta tiles as roof cladding, as tested in EWFA 2368000.1 and EWFA 2398800.1, instead of metal sheet cladding.

In the referenced test, EWFA 2398800.1, the specimen consisted of a concrete tile roof system incorporating a valley gutter. When tested, it achieved BAL FZ rating with a safety margin and the maximum internal temperature measured on the concrete tile was 450 °C at 30 minutes.

In the referenced test, EWFA 2368000.1, the specimen consisted of a concrete tile roof system incorporating plywood roof lining. When tested, it failed the performance criteria as the maximum temperature of the internal plywood fascia exceeded 300 °C at 62 minutes. The maximum internal temperature measured on the concrete tile was 423 °C at 30 minutes. The insulation failure at the fascia of the roof system tested in EWFA 2368000.1 can be attributed to the inadequate sealing at the interface of the anti-bonding board and pine fascia as the hot gasses reached the top section of the internal fascia through gaps at the interface. On the contrary, in the referenced test, EWFA 2398800.1, better sealing at the interface of the anti-bonding board and the fascia board effectively restricted the flow of hot gases into the roof cavity.

With reference to FRT220335 R1.0, the maximum internal temperature measured on the steel sheets was 813 °C at 30 minutes. Based on the temperatures recorded on the internal quarter and centre points of the steel sheets and concrete tiles, it is considered that the tile roofing is less onerous than the roof sheeting.

Therefore, the proposed variation to install concrete or terracotta tiles as roof cladding, as tested in EWFA 2368000.1 and EWFA 2398800.1, instead of metal sheet cladding can be positively assessed for BAL FZ in accordance with AS 1530.8.2:2018.

7.3.2 Truss of rafter spacing

For the frame of the roof system, it is proposed to maintain the truss or rafter spacing at a maximum of 600 mm-

In the referenced tests, EWFA 2398800.1 and EWFA 2368000.1, the specimens consisted of a series of timber roof rafters at approximately 600 mm centres made from 90 × 35 mm elements. Hence, it is recommended to maintain a maximum spacing of 600 mm between two rafters or trusses when constructing the framing of the proposed concrete or terracotta tile roof system.

The framing and safe spans of battens must be sized and designed by a professional structural engineer according to relevant standards, considering design load combinations at ambient and elevated temperatures.

Based on the above, it is considered that the structural adequacy of the proposed steel framing will not be detrimentally affected in accordance with AS 1530.8.2:2018.

7.3.3 Roof tile profile

It is proposed that the concrete and terracotta roof tiles shall be of various profiles ranging from 46 kg/m² to 54 kg/m².

A pilot study of various profiles of tiles was undertaken in tests BWA 2358300, BWA 2367700 and EWFA 2434700. The objective of the study was to investigate the influence of gaps around the tiles, tile shape, tile material, and tile mass. The results of the test are shown in Appendix B. The tests were conducted on representative sections of the roof area only, with no enclosure behind and no eaves or fascia construction. The specimens were assembled in a vertical orientation with the tiles screwed to the battens and tested in accordance with AS 1530.8.2:2007.

Upon careful inspection of the profile of the tiles, it was observed that the lighter profiled concrete tiles possessed more gaps due their irregular shape and the particular interlocking and weather sealing details. The flat terracotta tile, however, had a tighter interlock and greater mass. Upon inspection of the results of the tests, it was observed that the terracotta tile roof system reached the highest non-fire side temperature of 100 °C at 34 minutes. The curved and flat concrete profiled tile roof systems reached their highest non-fire side temperature at 52 minutes (60 °C) and 80 minutes (80 °C), respectively.

This indicates that the flat, heavier concrete tile delivered heat to the non-fire side for a longer time and made it hotter for a longer time. This does appear reasonable for the concrete tiles, as it is expected that larger tiles would have a greater heat capacity and therefore, having absorbed more energy during the heating period, would continue to radiate heat through the specimen. However, the curved and more open terracotta and concrete tiles reached a maximum temperature sooner and cooled down quicker as the heat was able to escape from the cavity beneath them. The higher heat capacity of the flat concrete tile is also combined with a generally tighter fit. This tighter fit restricts air movement into and out of the cavity with respect to the curved tile, keeping the heat inside.

When tested, the internal tile temperatures were similar, with the curved and flat concrete tiles reaching 740 °C and 730 °C, respectively, while the terracotta tile reached 650 °C. The proposed concrete tiles are 46 kg/m² rather than the 50 kg/m² as tested. Based on the above discussion, it is apparent that the less dense tiles reach similar temperatures to the denser tiles, though the denser tiles retain more heat and therefore impose a greater heat load on the system after the heating phase. It is possible that the lighter tile could result in a high tile temperature; however, due to the lack of combustible materials near the tiles and the quicker cooling of the tile, it is expected that the influence of the lighter mass will not result in a failure of any of the test criteria for BAL FZ in accordance with AS 1530.8.2:2018.

Based on the above discussion, the flat concrete tile is expected to

- achieve similar non-fire side temperatures as the tested profiled concrete and terracotta tiles.
- retain heat longer and result in higher temperatures within the roof cavity space.

- reach very similar internal tile temperatures as the profiled tiles with more gaps.

Therefore, it is considered that the flat concrete tile is more onerous than the lighter profiled concrete tiles and the heavy terracotta tile proposed in accordance with AS 1530.8.2:2018.

Based on the above discussion, it is considered that the tiles tested in EWFA 2368000.1 and EWFA 2398800.1 can be considered more onerous than the proposed tiles; hence, the proposal is therefore positively assessed.

7.3.4 Roof cavity insulation

It is proposed that the roof cavity insulation be 50 mm thick Trafalgar Fire rockwool insulation (nominally 60 kg/m³) with foil face on the top side instead of the 32 mm thick CSR Bradford Supertel 38 mm thick (32 kg/m³) glasswool insulation tested in EWFA 2368000.1.

The proposed rockwool insulation is of higher density and thickness compared to the glasswool insulation. Therefore, it is expected that Trafalgar Fire rockwool insulation will achieve improved thermal performance compared to the tested glasswool insulation.

Based on the above discussion and in the absence of any adverse risk, the proposed insulation is positively assessed for BAL FZ in accordance with AS 1530.8.2:2018.

7.3.5 Barge or gable detail

It is proposed to install the barge or gable detail of the tile roof system as shown in Figure 10.

The key aspect of the protection of the barge detail is the Trafalgar TRock Insulation blanket laid directly over the top of the Trafalgar Fire Siderise Spandrel Board at the edge of the roof. The rockwool insulation is expected to prevent free flow of hot gases from the furnace as it is compressed against the edges of the battens and the roof tiles to prevent gap formation at this location.

The barge detail reference can be made to the test EWFA 2398800.1 and EWFA 2368000.1. In each case, the construction of the proposed barge detail is similar to that of the eave detail tested. The proposed barge details possess the key functional aspects of the details tested at the eaves. Based on the above discussion and in the absence of any apparent risk, the proposed barge and gable details are positively assessed for BAL FZ in accordance with AS 1530.8.2:2018.

7.3.6 Hip and ridge detail

It is proposed that the hip and ridge detail of the tile roof system be as shown in Figure 11.

It is confirmed that the proposed ridge and hip detail is similar to that tested in EWFA 2398800.1. The proposed hip and ridge detail possesses the key functional aspects of the tested detail.

Based on the above discussion and in the absence of any apparent risk, the proposed hip and ridge detail is positively assessed for BAL FZ in accordance with AS 1530.8.2:2018.

7.3.7 Valley detail

It is confirmed that the proposed hip and valley details for tile roof systems shown in Figure 12 are similar to those tested for sheet roof systems.

When tested, the roof tiles tended to be somewhat cooler than sheet roofing, and as such it is expected the roof's underlying temperatures are expected to be lower.

Based on the above discussion and in the absence of any apparent risk, the proposed valley details are positively assessed for BAL FZ in accordance with AS 1530.8.2:2018.

7.3.8 Roof framing options

It is proposed to install the roof battens vertically (parallel to the roof frame timbers) and incorporate horizontal roof tile battens as tested in EWFA 2368000.1 and EWFA 2398800.1.

It is confirmed that the proposed construction detail of the roof framing is similar to that tested in EWFA 2368000.1 and EWFA 2398800.1. Hence, in the absence of any adverse risk, the proposed construction can be positively assessed for BAL FZ in accordance with AS 1530.8.2:2018.

7.4 Conclusion

Based on the above discussion, it is considered that the proposed variations to the concrete and terracotta tile roof systems protected with Trafalgar Fire roof protection system are expected to achieve BAL FZ as shown in Table 12 in accordance with AS 1530.8.2:2018.

Property of Trafalgar Group

Table 12 Variations and assessment outcome for concrete or terracotta tile roof system

Item	Reference tests	Description	Variations	BAL rating
Concrete or terracotta tile roof	FRT220335 R1.0 EWFA 2368000.1 EWFA 2398800.1 EWFA 2434700 BWA 2358300 BWA 2367700	EWFA 2368000.1 included a concrete tile roof system incorporating plywood roof lining tested in accordance with AS 1530.8.2:2007. EWFA 2398800.1 included a concrete tile roof system incorporating a valley gutter system tested in accordance with AS 1530.8.2:2007. BWA 2358300, BWA 2367700 and EWFA 2434700 included vertical roofing systems with a plywood substrate and fibreglass blanket insulation tested in general accordance with AS 1530.8.2:2007.	<p>The following variations are to be assessed in accordance with AS 1530.8.2:2018 using the results of the referenced tests.</p> <ul style="list-style-type: none"> The roof cladding options include concrete or terracotta tiles, with variations in profile and mass ranging from 46 kg/m² to 54 kg/m² The roof framing can be constructed using either trusses or rafters with a maximum spacing of 600 mm. 50 mm thick Trafalgar Fire rockwool insulation with foil face on the top face (nominal density of 60 kg/m³ as the roof cavity insulation Inclusion of typical barge and gable (Figure 10), hip (Figure 11), and valley (Figure 12) details Roofing battens to be installed vertically (parallel to roof frame timbers) and incorporate horizontal roof tile battens as tested in EWFA 2368000.1 and EWFA 2398800.1. 	BAL FZ

8. Validity

Warringtonfire Australia does not endorse the tested or assessed products and systems in any way. The conclusions of this assessment may be used to directly assess the fire hazard, but it should be recognised that a single test method will not provide a full assessment of fire hazard under all conditions.

Due to the nature of fire testing and the consequent difficulty in quantifying the uncertainty of measurement, it is not possible to provide a stated degree of accuracy. The inherent variability in test procedures, materials and methods of construction, and installation may lead to variations in performance between elements of similar construction.

This assessment is based on test data, information and experience available at the time of preparation. If contradictory evidence becomes available to the assessing authority, the assessment will be unconditionally withdrawn and the report sponsor will be notified in writing. Similarly, the assessment should be re-evaluated, if the assessed construction is subsequently tested since actual test data is deemed to take precedence.

The procedures for the conduct of tests and the assessment of test results are subject to constant review and improvement. The sponsor is therefore recommended that this report be reviewed on, or before, the stated expiry date.

This assessment represents our opinion about the performance of the proposed systems that is expected to be demonstrated when subjected to test conditions in accordance with AS 1530.8.2:2018, based on the evidence referred to in this report.

This assessment is provided to Trafalgar Group Pty Ltd. for their own specific purposes. This report may be used as evidence of suitability in accordance with the requirements of the relevant National Construction Code. Building certifiers and other third parties must determine the suitability of the systems described in this report for a specific installation.

Appendix A Drawings and additional information

Table 13 Details of drawings

Figure No	Figure title	Source
Figure 1	Plan view of metal sheet roof system protected by Trafalgar Fire BAL FZ roof protection elements	Provided by Trafalgar Group Pty Ltd.
Figure 2	Through section view of metal sheet roof system protected by Trafalgar Fire BAL FZ roof protection elements	
Figure 3	Eave section view of metal sheet roof system protected by Trafalgar Fire BAL FZ roof protection elements	
Figure 4	Barge & gable section view of metal sheet roof system protected by Trafalgar Fire BAL FZ roof protection elements	
Figure 5	Hip and ridge section view of metal sheet roof system protected by Trafalgar Fire BAL FZ roof protection elements	
Figure 6	Valley section view of metal sheet roof system protected by Trafalgar Fire BAL FZ roof protection elements	
Figure 7	Example of cut away plan of a typical tile roof system showing ridge and valley	
Figure 8	Example of timber frame tile roof system protected by Trafalgar Fire BAL FZ roof protection elements (Section A-A of Figure 7)	
Figure 9	Example of eave detail (Section D-D of Figure 7)	
Figure 10	Example of barge and gable detail (Section E-E of Figure 7)	
Figure 11	Example of hip detail	
Figure 12	Valley construction (Section C-C of Figure 7)	
Figure 13	Plan view showing fixing centres for Trafalgar Fire BoardeX linings	Provided by Trafalgar Group Pty Ltd.
Figure 14	Plan view showing fixing centres for Trafalgar Fire BoardeX fascia	
Figure 15	Plan view showing fixing centres for Trafalgar Fire Siderise Spandrel board	
Figure 16	Side view of the metal sheet roof system with vertically installed battens	
Figure 17	Isometric overview of the metal sheet roof system with vertically installed battens	

Appendix B Summary of supporting test data

B.1 Test report – FRT220335 R1.0

Table 14 Information about test report

Item	Information about test report
Report sponsor	Trafalgar Group Pty Ltd
Test laboratory	Warringtonfire Australia, 409-411 Hammond Road, Dandenong, Victoria 3175, Australia.
Test date	The fire resistance test was done on 9 February 2023.
Test standards	The test was done in accordance with AS 1530.8.2:2018.
Variation to test standards	None
General description of tested specimen	<p>The tested specimen consisted of an 1875 mm tall × 2270 mm wide fire facing roof system and consisted of 90 x 45 MGP timber rafters pitched at 45 °.</p> <p>One layer of 12.5 mm BoardeX panel was fixed vertically on to the top side of the timber framing. Panel to panel joins and panel to timber interfaces were sealed using TREMstop PU+ fire rated polyurethane joint sealant. No cladding was used on the unexposed side of the timber framing.</p> <p>40 mm top hats were installed horizontally on top of the BoardeX panel, with one layer of mineral wool insulation spread across the top of the top hats.</p> <p>The Custom ORB® sheets were fixed to the top hats, sandwiching all the mineral wool insulation that crossed over the top of the top hats.</p> <p>25 mm Siderise CW-FB insulation was installed at the fascia to roof corner, including the underside of the roof.</p> <p>The fascia and gutter were then fixed to the fascia board.</p>
Instrumentation	The test report states that the instrumentation was in accordance with AS 1530.8.2:2018.

The test specimen achieved the following results – see Table 15.

Table 15 Results summary for this test report

Performance criteria	Result
A gap from the fire-exposed face to the non-fire exposed face greater than 3 mm	No failure
Sustained flaming for more than 10 s on the non-fire side for the duration of the 90 min test period	No failure
Flaming on the fire-exposed side more than 30 min after completion of heating	No failure
Radiant heat flux 365 mm from the non-fire side exceeding 15 kW/m ²	Not applicable
Mean and maximum temperature rises greater than 140 K and 180 K	No failure
Radiant heat flux 250 mm from the specimen, greater than 3 kW/m ² more than 30 min after completion of the heating phase	No failure
Mean and maximum temperature of internal faces exceeding 250 °C and 300 °C respectively more than 30 min after completion of heating phase	No failure
Performance Achieved	BAL FZ

B.2 Test report – EWFA 2394700.1

Table 16 Information about test report

Item	Information about test report
Report sponsor	Forest and Wood Products Australia
Test laboratory	Exova Warringtonfire Aus Pty Ltd, Unit 2, 409-411 Hammond Road, Dandenong, Victoria 3175, Australia.
Test date	The fire resistance test was done on 25 September 2009.
Test standards	The test was done in accordance with AS 1530.8.2:2007.
Variation to test standards	None
General description of tested specimen	<p>The test specimen comprised an internal framed truss system made from 90 mm × 35 mm timber rafters with a 9 mm thick layer of Promat PROMATECT® 40, incorporating a representative valley gutter system.</p> <p>The PROMATECT® 40 was fixed to the raked surface. 90 mm × 45 mm pine battens were positioned on the exposed side of the PROMATECT® 40 to support the roof sheeting.</p> <p>At the eaves edge of the roof, a 0.55 mm BMT Z-section cavity closure flashing was installed. The first roof batten was 75 mm away from the eaves edge and a 90mm wide 75 mm thick strip of Bradford Fibretex 650 Rockwool was positioned on edge and compressed under the Anticon and roofing when the roof was fixed.</p> <p>A layer of Bradford 55 mm Light Duty Anticon blanket with the foil side down was installed over whole roof area on top of the battens.</p> <p>The roof sheeting was 0.42 mm thick BlueScope custom ORB. It was fixed through the Anticon into the battens at every second corrugation in the field of the roof, and at every second corrugation at the ridge and fascia.</p> <p>The fascia construction comprised a 35 mm framing angle fixed between the trusses. Fire grade plasterboard and then PROMATECT® 40 was fixed to the ends of the trusses and the framing angles.</p> <p>Promat PROMASEAL® AN acrylic sealant was applied to the gap under the cavity closure flashing. The Fascia system was a LYSAGHT Novaline steel fascia section, fixed with Novaline fascia clips bent at 90 degrees and fixed through the plasterboard to the blocks or trusses. The butt joints in the PROMATECT® 40 was offset by 200 mm from the plasterboard joint.</p> <p>The eaves incorporated one layer of 16 mm fire grade plasterboard with all joints in the board backed by framing or 35 mm × 35 mm × 0.70 mm mild steel angles. The gaps in the sheets at the perimeter were filled with Promat PROMASEAL® AN acrylic sealant. The plasterboard was then overlaid with a layer of 9 mm PROMATECT® 40.</p> <p>At the valley, 16 mm BORAL Wet Area plasterboard was installed between the two Z-section cavity closure flashings (which continued from the eaves edge of the roof). This plasterboard was protected on the fire side with Proctor Roofshield. The valley was then screw fixed to these boards through to the PROMATECT® 40 boards.</p>
Instrumentation	The test report states that the instrumentation was in accordance with AS 1530.8.2:2007.

The test specimen achieved the following results – see Table 17.

Table 17 Results summary for this test report

Criteria	Result
Formation of an opening from the fire-exposed face to the non-fire-exposed face of the element through which a 3mm diameter probe can penetrate for the duration of the 90-minute test period.	No Failure
Sustained flaming for more than 10 seconds on the non-fire-side for the duration of the 90 minute test period.	No Failure

Criteria	Result
Flaming on the fire-exposed side more than 30 min after termination of the heating phase, that is, flaming on the fire exposed face during the last 30 min of the monitoring phase.	No Failure
Radiant heat flux 365 mm from the non-fire side of the specimen in excess of 15 kW/m ² from glazed and uninsulated areas during the 30 min exposure and for a subsequent 60 min test period.	N/A
Mean and maximum temperature rises greater than 140°C and 180°C on the non-fire-side during the 30 min heating regime and for a subsequent 60 min period.	Roof - No Failure Fascia – No Failure Eaves – No Failure
Radiant heat flux 250mm from the fire-exposed face of the specimen, greater than 3 kW/m ² more than 30 min after completion of the heating phase that is, flaming on the fire exposed face during the last 30 min of the monitoring phase.	No Failure
Mean and maximum temperatures of the internal faces of construction including cavities, exceed 250°C and 300°C, 30 min or more after completion of the heating phase.	Roof – No Failure Fascia – No Failure
Performance Achieved	BAL FZ

Property of Trafalgar Group

B.3 Test report – EWFA 2368000.1

Table 18 Information about test report

Item	Information about test report
Report sponsor	Roofing Tile Association of Australia
Test laboratory	Exova Warringtonfire Aus Pty Ltd, Unit 2, 409-411 Hammond Road, Dandenong, Victoria 3175, Australia.
Test date	The fire resistance test was done on 13 August 2009.
Test standards	The test was done in accordance with AS 1530.8.2:2007.
Variation to test standards	None
General description of tested specimen	<p>The test specimen comprised a series of timber roof trusses at 600 mm centres made from 90 mm × 35 mm elements lined on the top chord with a 15 mm thick layer of pine plywood.</p> <p>A layer of CSR Bradford Supertel (32 kg/m³) 38 mm thick insulation was installed over the whole roof area. Lysaght Topspan 40 top hat counter battens were positioned vertically at nominal 600 mm centres on the exposed side of the plywood.</p> <p>On top of the battens to the exposed side a layer of Enviroseal sarking was installed with four steel battens fixed horizontally across the specimen to the steel counter battens.</p> <p>Bristile Lodge concrete roof tiles were fixed to tile battens using needlepoint screws.</p> <p>The eaves incorporated 1-off layer of 15 mm thick plywood fixed to the frame, with 16 mm Boral FireStop fixed to the surface of the plywood, with the interface with the fascia and non-combustible wall sealed with Bostik Fireban One Polyurethane sealant. 4.5 mm thick Fibre cement sheet was screw fixed (200 mm centres) to the trusses on the eaves on the exposed surface.</p> <p>The fascia construction comprised of 15 mm pine plywood fixed between the truss top chords, lined with a layer of 16 mm Boral Wet Area plasterboard. The Fascia system was finished with a 19 mm thick pine fascia board fixed to truss framing.</p> <p>Bradford Fireseal Rockwool (uncompressed) was positioned over the counter battens at the interface of the roof and fascia.</p> <p>At the ridge edge of the roof, 100 mm high × 90 mm wide section of Rockwool was vertically positioned under the ridge capping. A ridge capping was fixed over the ridge of the roof with an approximate 20 mm overlap from one ridge tile to the next and set on a nominal 40mm thick bed of mortar.</p> <p>Anti-ponding board was screw fixed to all counter battens over the Rockwool with one screw at the top of the board, nominal 20 mm from the top.</p>
Instrumentation	The test report states that the instrumentation was in accordance with AS 1530.8.2:2007.

The test specimen achieved the following results – see Table 19.

Table 19 Results summary for this test report

Criteria	Result
Formation of an opening from the fire-exposed face to the non-fire-exposed face of the element through which a 3 mm diameter probe can penetrate for the duration of the 90-minute test period.	No Failure
Sustained flaming for more than 10 s on the non-fire-side for the duration of the 90 min test period.	No Failure
Flaming on the fire-exposed side more than 30 min after termination of the heating phase, that is, flaming on the fire exposed face during the last 30 min of the monitoring phase.	No Failure

Criteria	Result
Radiant heat flux 365 mm from the non-fire side of the specimen in excess of 15 kW/m ² from glazed and uninsulated areas during the 30 min exposure and for a subsequent 60 min test period.	N/A
Mean and maximum temperature rises greater than 140K and 180K on the non fire-side during the 30 min heating regime and for a subsequent 60 min period.	Roof- No Failure Fascia – Failure Eaves/Soffit – No Failure
Radiant heat flux 250 mm from the fire-exposed face of the specimen, greater than 3 kW/m ² more than 30 min after completion of the heating phase that is, flaming on the fire exposed face during the last 30 min of the monitoring phase.	No Failure
Mean and maximum temperatures of the internal faces of construction including cavities, exceed 250°C and 300°C, 30 min or more after completion of the heating phase.	Roof- Failure Fascia- No Failure

Property of Trafalgar Group

B.4 Test report – EWFA 2398800.1

Table 20 Information about test report

Item	Information about test report
Report sponsor	Roofing Tile Association of Australia
Test laboratory	Exova Warringtonfire Aus Pty Ltd, Unit 2, 409-411 Hammond Road, Dandenong, Victoria 3175, Australia.
Test date	The fire resistance test was done on 18 August 2009.
Test standards	The test was done in accordance with AS 1530.8.2:2007.
Variation to test standards	None
General description of tested specimen	<p>The test specimen incorporated an internal framed truss system of 90 mm × 35 mm timber rafters with a 15 mm thick layer of plywood fixed to the exposed raked surface.</p> <p>A layer of CSR Bradford Flexitel (25 kg/m³) 38 mm thick insulation was installed over the whole roof area. Lysaght Topspan 40 top hat counter battens were fixed to exposed side of the plywood and framing below through insulation.</p> <p>On top of the battens to the exposed side a layer of Enviroseal sarking was installed with three steel battens fixed horizontally across the specimen to the steel counter battens to which the tiles with flat profile were fixed to.</p> <p>Bristle Lodge concrete roof tiles (5.5 kg/tile) were fixed to tile battens using needlepoint screws.</p> <p>The eaves incorporated 1-off layer of 15 mm thick plywood fixed to the frame, with 16 mm CSR Fyrchek plasterboard (stated by the client) fixed to the surface of the plywood, with the interface with the fascia and non-combustible wall sealed with Bostik Fireban One Polyurethane sealant. 4.5 mm thick Fibre cement sheet was screw fixed at 200 mm centres to the trusses on the eaves on the exposed surface.</p> <p>The fascia construction comprised of 15 mm pine plywood fixed between the truss top chords, lined with a layer of 16 mm CSR Fyrchek plasterboard (stated by the client). The Fascia system was finished with a 19 mm thick pine fascia board fixed to truss framing.</p> <p>Bradford Fireseal Rockwool (uncompressed) was installed at the bottom of the valley and along the lower edge of the roof on top of the Rockwool, a 16 mm fire grade plasterboard (Anti-ponding board) was installed which terminated on top of the fascia. The interface was sealed with Bostik Fireban One Polyurethane sealant.</p> <p>Within the valley, a valley gutter was installed along the entire length, with valley gutter guard installed on top of the valley gutter.</p>
Instrumentation	The test report states that the instrumentation was in accordance with AS 1530.8.2:2007.

The test specimen achieved the following results – see Table 21.

Table 21 Results summary for this test report

Criteria	Result
Formation of an opening from the fire-exposed face to the non-fire-exposed face of the element through which a 3 mm diameter probe can penetrate for the duration of the 90-minute test period.	No Failure
Sustained flaming for more than 10 s on the non-fire-side for the duration of the 90-minute test period.	No Failure
Flaming on the fire-exposed side more than 30 min after termination of the heating phase, that is, flaming on the fire exposed face during the last 30 min of the monitoring phase.	No Failure
Radiant heat flux 365 mm from the non-fire side of the specimen in excess of 15 kW/m ² from glazed and uninsulated areas during the 30 min exposure and for a subsequent 60 min test period.	N/A

Criteria	Result
Mean and maximum temperature rises greater than 140K and 180K on the non-fire-side during the 30 min heating regime and for a subsequent 60 min period.	Roof- No Failure Fascia – No Failure Eaves/Soffit – No Failure
Radiant heat flux 250 mm from the fire-exposed face of the specimen, greater than 3 kW/m ² more than 30 min after completion of the heating phase that is, flaming on the fire exposed face during the last 30 min of the monitoring phase.	No Failure
Mean and maximum temperatures of the internal faces of construction including cavities, exceed 250°C and 300°C, 30 min or more after completion of the heating phase.	Roof- No Failure Fascia- No Failure

Property of Trafalgar Group

B.5 Test report – BWA 2358300

Table 22 Information about test report

Item	Information about test report
Report sponsor	Roofing Tile Association of Australia
Test laboratory	Bodycote Warringtonfire (Aus) Pty Ltd, Unit 2, 409-411 Hammond Road, Dandenong, Victoria 3175, Australia.
Test date	The fire resistance test was done on 23 June 2009.
Test standards	The test was done in general accordance with AS 1530.8.2:2007.
Variation to test standards	None
General description of tested specimen	<p>A pilot scale test was conducted in general accordance with AS 1530.8.2 on a 1.2 m × 1.2 m vertical roofing system.</p> <p>The tested configuration incorporated 90 × 35 mm timber pine studs that were fixed vertically to the unexposed side of a layer of 15 mm thick plywood board, with 50 mm deep counter battens fixed vertically on the ply on the exposed side, with metal top hats positioned horizontally on the fire side to which the tiles with the curved profile were fixed. In between the timber and steel battens 40 mm thick Fibreglass blanket was installed. The exposed perimeter of the specimen was sealed using ceramic fibre blanket.</p>
Instrumentation	<p>The test report states that the instrumentation was in accordance with AS 1530.8.2:2007.</p> <p>The pressure of the furnace was maintained within the limits specified in AS 1530.4:2005 of 20 ± 3 Pa at head of the specimen.</p>

The test specimen achieved the following results – see Table 23.

Table 23 Results summary for this test report

Criteria	Result
Formation of an opening from the fire-exposed face to the non-fire-exposed face of the element through which a 3 mm diameter probe can penetrate for the duration of the 90 minute test period.	No Failure
Sustained flaming for more than 10 s on the non-fire-side for the duration of the 90 min test period.	No Failure
Flaming on the fire-exposed side more than 30 min after termination of the heating phase, that is, flaming on the fire exposed face during the last 30 min of the monitoring phase.	No Failure
Radiant heat flux 365 mm from the non-fire side of the specimen in excess of 15 kW/m ² from glazed and uninsulated areas during the 30 min exposure and for a subsequent 60 min test period.	N/A
Mean and maximum temperature rises greater than 140 K and 180 K on the non-fire-side during the 30 min heating regime and for a subsequent 60 min period.	No Failure
Radiant heat flux 250 mm from the fire-exposed face of the specimen, greater than 3 kW/m ² more than 30 min after completion of the heating phase, that is, flaming on the fire exposed face during the last 30 min of the monitoring phase.	No Failure
Mean and maximum temperatures of the internal faces of construction including cavities, exceed 250°C and 300°C, 30 min or more after completion of the heating phase.	No Failure

B.6 Test report – BWA 2367700

Table 24 Information about test report

Item	Information about test report
Report sponsor	Roofing Tile Association of Australia
Test laboratory	Bodycote Warringtonfire (Aus) Pty Ltd, Unit 2, 409-411 Hammond Road, Dandenong, Victoria 3175, Australia.
Test date	The fire resistance test was done on 23 June 2009.
Test standards	The test was done in general accordance with AS 1530.8.2:2007.
Variation to test standards	None
General description of tested specimen	<p>A pilot scale test was conducted in general accordance with AS 1530.8.2 on a 1.2 m × 1.2 m vertical roofing system.</p> <p>The tested configuration incorporated 90 × 35 mm timber pine studs that were fixed vertically to the unexposed side of a layer of 15 mm thick plywood board, with 50 mm deep counter battens fixed vertically on the ply on the exposed side, with metal top hats positioned horizontally on the fire side to which the tiles with the curved profile were fixed. In between the timber and steel battens, 40 mm thick Fibreglass blanket was installed. The exposed perimeter of the specimen was sealed using ceramic fibre blanket.</p> <p>The pressure of the furnace was maintained within the limits specified in AS 1530.4:2005 of 20 ± 3 Pa at the head of the specimen.</p>
Instrumentation	The test report states that the instrumentation was in accordance with AS 1530.8.2:2007.

The test specimen achieved the following results – see Table 25.

Table 25 Results summary for this test report

Criteria	Result
Formation of an opening from the fire-exposed face to the non-fire-exposed face of the element through which a 3 mm diameter probe can penetrate for the duration of the 90 minute test period.	No Failure
Sustained flaming for more than 10 s on the non-fire-side for the duration of the 90 min test period.	No Failure
Flaming on the fire-exposed side more than 30 min after termination of the heating phase, that is, flaming on the fire exposed face during the last 30 min of the monitoring phase.	Failure
Radiant heat flux 365 mm from the non-fire side of the specimen in excess of 15 kW/m ² from glazed and uninsulated areas during the 30 min exposure and for a subsequent 60 min test period.	N/A
Mean and maximum temperature rises greater than 140 K and 180 K on the non-fire-side during the 30 min heating regime and for a subsequent 60 min period.	No Failure
Radiant heat flux 250 mm from the fire-exposed face of the specimen, greater than 3 kW/m ² more than 30 min after completion of the heating phase, that is, flaming on the fire exposed face during the last 30 min of the monitoring phase.	Failure
Mean and maximum temperatures of the internal faces of construction including cavities, exceed 250°C and 300°C, 30 min or more after completion of the heating phase.	Failure

B.7 Test report – BWA 2434700

Table 26 Information about test report

Item	Information about test report
Report sponsor	Roofing Tile Association of Australia
Test laboratory	Bodycote Warringtonfire (Aus) Pty Ltd, Unit 2, 409-411 Hammond Road, Dandenong, Victoria 3175, Australia.
Test date	The fire resistance test was done on 23 December 2009.
Test standards	The test was done in general accordance with AS 1530.8.2:2007.
Variation to test standards	None
General description of tested specimen	<p>A full scale test was conducted in general accordance with AS 1530.8.2 on a 1.2 m × 1.2 m vertical roofing system.</p> <p>The tested configuration incorporated 90 × 35 mm timber pine studs that were fixed vertically to the unexposed side of a layer of 15 mm thick plywood board, with 50 mm deep steel counter battens fixed vertically to the ply on the exposed side, with steel roof tile battens positioned horizontally on the fire side to which the ceramic tiles were fixed to. In between the plywood board and the steel counter battens, 40 mm thick Fibreglass blanket was installed. In between the steel roof tile battens and the steel counter battens, a layer of sarking was installed. The exposed perimeter of the specimen was sealed using ceramic fibre blanket.</p> <p>The pressure of the furnace was maintained within the limits specified in AS 1530.4:2005 of 20 ± 3 Pa at the head of the specimen.</p>
Instrumentation	The test report states that the instrumentation was in accordance with AS 1530.8.2:2007.

The test specimen achieved the following results – see Table 27.

Table 27 Results summary for this test report

Criteria	Result
Formation of an opening from the fire-exposed face to the non-fire-exposed face of the element through which a 3 mm diameter probe can penetrate for the duration of the 90 minute test period.	No Failure
Sustained flaming for more than 10 s on the non-fire-side for the duration of the 90 min test period.	No Failure
Flaming on the fire-exposed side more than 30 min after termination of the heating phase, that is, flaming on the fire exposed face during the last 30 min of the monitoring phase.	No Failure
Radiant heat flux 365 mm from the non-fire side of the specimen in excess of 15 kW/m ² from glazed and uninsulated areas during the 30 min exposure and for a subsequent 60 min test period.	N/A
Mean and maximum temperature rises greater than 140 K and 180 K on the non-fire-side during the 30 min heating regime and for a subsequent 60 min period.	No Failure
Radiant heat flux 250 mm from the fire-exposed face of the specimen, greater than 3 kW/m ² more than 30 min after completion of the heating phase, that is, flaming on the fire exposed face during the last 30 min of the monitoring phase.	No Failure
Mean and maximum temperatures of the internal faces of construction including cavities, exceed 250°C and 300°C, 30 min or more after completion of the heating phase.	No Failure