



CONTROL AND EXPANSION JOINTS

Control, movement or expansion joints are an important part of good building practice. They are used to allow for movement and expansion and stop unsightly cracking. When we incorporate a control joint into fire rated walls or fire rated floor slabs, these control joints must incorporate fire rated materials to provide an as tested fire rated control joint system.



KEY FEATURES

- Tested to AS1530.4-2014
- Australian made
- FRL's up to-/240/240
- 10% movement capability
- Acoustic properties
- Various joint configurations tested
- Water based for easy cleanup
- White or grey
- Cartridges, sausages or pails
- Made with recycled materials
- Low VOC

APPLICATIONS

- **FyreFLEX is tested and suitable for:**
 - Control joints
 - Expansion joints
 - Head of wall joints
 - T-junctions
 - Service penetrations

For details on electrical or plumbing penetrations with FyreFLEX® sealant, contact **Trafalgar Fire at :** technical@tgroup.com.au

TRADES



TABLE OF CONTENTS



Section	Page	
What are control joints	3	
Compliance	3	
What is FyreFLEX	4	
Applications	4	
Acoustics	5	
Fire Resistance Level	6	
FRL Tables	Head of Wall Joints: Plasterboard, Concrete/ Masonry	7
	Vertical Control Joints: Plasterboard, Concrete/ Masonry	8
	Horizontal Joints In Between Concrete Slabs: Concrete floors	9
	T-Joints Between Two Perpendicular Walls: Plasterboard, Concrete/ Masonry	10
Installation instructions	11	
System Range	12-13	
FAQ	14	
Technical Drawings	Head of Wall Control Joint- Between single layer plasterboard wall and concrete slab	15
	Head of Wall Control Joint- Between double layer plasterboard wall and concrete slab	16
	Head of Wall Control Joint- Between concrete/ masonry wall (116mm) and concrete slab	17
	Head of Wall Control Joint- Between concrete/ masonry wall (140mm) and concrete slab	18
	Horizontal control joints- Concrete floor slabs	19
	T-Joint between single layer plasterboard walls	20
	T-Joint between double layer plasterboard walls	21
	T-Joint between single layer plasterboard wall and a concrete / masonry wall	22
	T-Joint between double layer plasterboard wall and a concrete / masonry wall	23
	T-Joint 90mm thick concrete / masonry walls	24
	T-Joint 140 mm thick concrete / masonry walls	25
	T-Joint between a shaftliner wall and a concrete / masonry wall	26
	Vertical control joint- concrete / masonry wall with 30mm wide control joint	27
	Vertical control joint- concrete / masonry wall with 20mm wide control joint, for a two-way FRL	28
	Vertical control joint- concrete / masonry wall with 30mm wide control joint, for a one-way FRL	29
	Vertical control joint- plasterboard walls (single layer) with 20mm wide control joint	30
Vertical control joint- plasterboard walls (double layer) with 20mm wide control joint	31	
Vertical control joint- shaftliner wall with 20mm wide control joint	32	

BENEFITS - CONTROL JOINTS

WHAT ARE CONTROL JOINTS ?

Control, movement or expansion joints are an important part of good building practice. They are used to allow for movement and expansion and stop unsightly cracking. When we integrate a control joint into fire rated walls or fire rated floor slabs, these control joints must incorporate fire rated materials to provide an as tested fire rated control joint System. Fire rated control joints like, one would expect, need to be fire tested to show that they will not reduce the FRL of the wall or floor slab they are being used in. Fire testing incorporating control joints must be conducted for all different wall types and floor slab types and thicknesses, and of course, with different joint widths to provide the requisite fire test reports for NCC compliance. The fires test prove that the control joint will not crack or shrink, and will stick to the substrate during real fire conditions, and prevent the passage of flames and hot gases, and equally will not get too hot on the surface of the joint on the cold or non-fire side of each fire test.

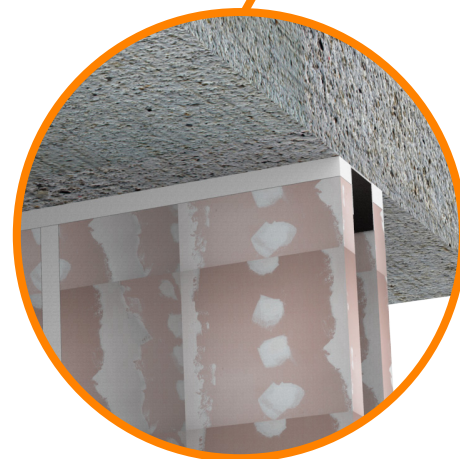
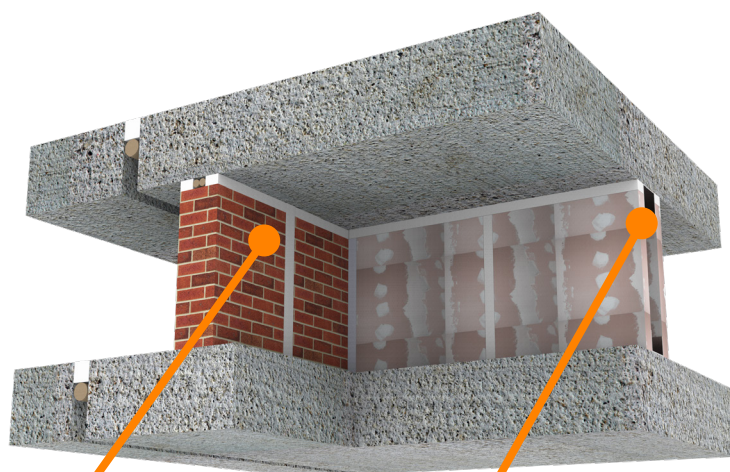

COMPLIANCE

The FRL, commonly incorrectly referred to as the fire rating, provides a measure of time for both the integrity of the control joint in fire conditions (ability to resist hot gases or ignition) and the high temperature insulation properties of the control joint; that is its ability to insulate the joint from the 1000 Degree plus temperature of the fire, and maintain temperatures on the non-fire or non-exposed surface below a temperature rise of 180 deg C. A so called one hour fire rating, which we often hear spoken of, is in fact for regulatory purposes and the NCC, an FRL of-/60/60; that is from an actual fire test to AS1530 Part 4, the joint in question, and the fire rated sealing material, for the given width of joint and depth of material used, and just as importantly the orientation it is installed, (one sided, or two sided application), successfully provided both integrity and insulation during the fire test, in the given wall or floor type being fire tested for at least 60 minutes duration. Similarly, a two hour fire rating would be an FRL of-/120/120.

BENEFITS - FyreFLEX® SEALANT



WHAT IS FyreFLEX®?

FyreFLEX® sealant is a water based, low VOC and environmentally friendly fire-resistant acrylic sealant with slight intumescent properties which makes it perfect for sealing joints between fire rated building elements (walls and floors) as well as fire stopping cable and metal pipe penetrations through fire rated barriers. FyreFLEX® is the one of the most fire tested sealants in the market with more than 40 fire and acoustic tests, and assessments spanning over 40 years.

FyreFLEX® has been approved for use in a large range of control joint or firestopping applications required under the National Construction Code (NCC). This technical manual in particular relates to sealing of joints. For service penetration systems refer to separate technical manuals:

-Plumbing services, including copper and steel pipes

<https://tfire.com.au/documents/FyreFLEX-and-TWRAP-Plumbers-Technical-Manual>

-Electrical penetrations for power and communication cables

<https://tfire.com.au/documents/FyreFLEX-and-TWRAP-Plumbers-Technical-Manual>

FyreFLEX is available in white, or grey for a more discrete finish on concrete and masonry applications.

APPLICATIONS

FyreFLEX® has a 10% movement capacity and is suitable for joints:

- Control joints
- Expansion joints
- Head of wall joints
- T-junctions

Metal plumbing / active fire pipes

- Copper Pipes
- Steel Pipes
- Stainless Steel Pipes



Power Cables

- Comms and data cables
- Cables power
- Cable bundles and trays

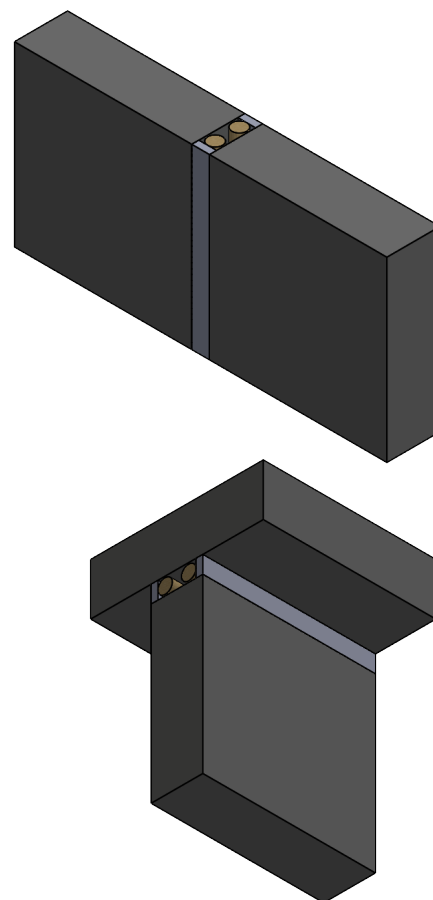

Note: For plastic pipe penetrations (PVC, PEX, etc.) refer to our technical manual for systems such as FyrePEX HP intumescent Sealant, and FyreCHOKE Collars.

BENEFITS



ACOUSTICS

Many fire-rated barriers also have a requirement for low sound transmission. As such control joints in fire rated walls can reduce the acoustic performance of the wall itself if not properly assessed.

FyreFLEX® Sealant has been tested for its acoustic properties to ensure it is suitable for these applications. Tested in a typical arrangement of plasterboard and masonry walls with joints up to 20mm wide, it has been found that FyreFLEX® Sealant is able to maintain the acoustic ratings with the following wall types:

- Head of wall joints with single layer plasterboard walls up to Rw50
- 140mm Concrete/Masonry wall acoustic rating of up to Rw53

Contact technical@tgroup.com.au if you have any questions.

SPECIFICATIONS



SPECIFICATIONS

	Movement Capabilities	+/- 10% movement
	Colour	White- for plasterboard walls and easy painting Grey- colour matched to concrete or blockwork
	Testing	Tested and approved to AS1530.4-2014 and AS4072.1 in accordance with the National Construction Code (NCC) along with TWRAP™, as part of the tested system
	Safety	Non-toxic, low VOC Please refer to the system MSDS for full safety information
	Shelf Life	24 months from date of manufacture
	Acoustics	Maintains acoustic performance of up to RW 54

FIRE RESISTANCE LEVEL



FIRE RATING – HOW IS FIRE PERFORMANCE MEASURED?

An FRL (fire resistance level) is a handy way of summarising the performance of a building element. It consists of 3 numbers, all given in minutes:

FRL 240/240/240

(example)



Structural Adequacy

The ability of the building element to support the weight of adjacent building elements.

ie: a brick wall supporting a concrete floor slab above.



Integrity

The ability of an element to prevent the passage of flames and hot gasses.

ie: a plasterboard wall remaining intact and not allowing holes to form.

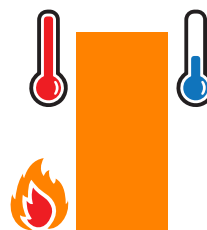

Insulation

The ability of an element to resist heat transfer from the exposed face to the unexposed face.

ie: a copper pipe remaining below a set temperature limit on the unexposed side of the wall penetration system.

Note: Control Joints are not required to have a Structural Adequacy rating and is usually expressed as a dash. For example, a control joint in a 4 hour load bearing wall would be written as -/240/240.

INTEGRITY

The FyreFLEX® system will achieve the integrity performance for up to 4 hours physically stopping the direct spread of fire, however the insulation performance of the penetration will be limited to the type of wall being used and conductivity of the services in the penetration.

INSULATION (TEMPERATURE RISE)

Heat rise via conduction will occur through all parts of the system, FyreFLEX is able to maintain its insulation performance under fire conditions in all common wall and floor types.

HEAD OF WALL JOINTS

PLASTERBOARD, CONCRETE/ MASONRY

Wall System	Joint details	FRL
Single-layer plasterboard walls minimum 96 mm thick (1 x 16 mm)	Maximum 30 mm wide, 16 mm from both sides	-/90/90
Double-layer plasterboard walls minimum 116 mm thick (2 x 13 mm or 2 x 16 mm).	Maximum 30 mm wide, with a depth of 16 mm from both sides	-/120/120
Masonry or concrete walls minimum 116mm thick. The masonry or concrete walls are designed in accordance with AS 3700 or AS 3600 respectively.	Maximum 20 mm wide, 16 mm from both sides	-/120/120
Masonry walls in accordance with AS 3700, minimum 140 mm thick.	Maximum 50 mm wide, 20 mm from both sides	-/180/180

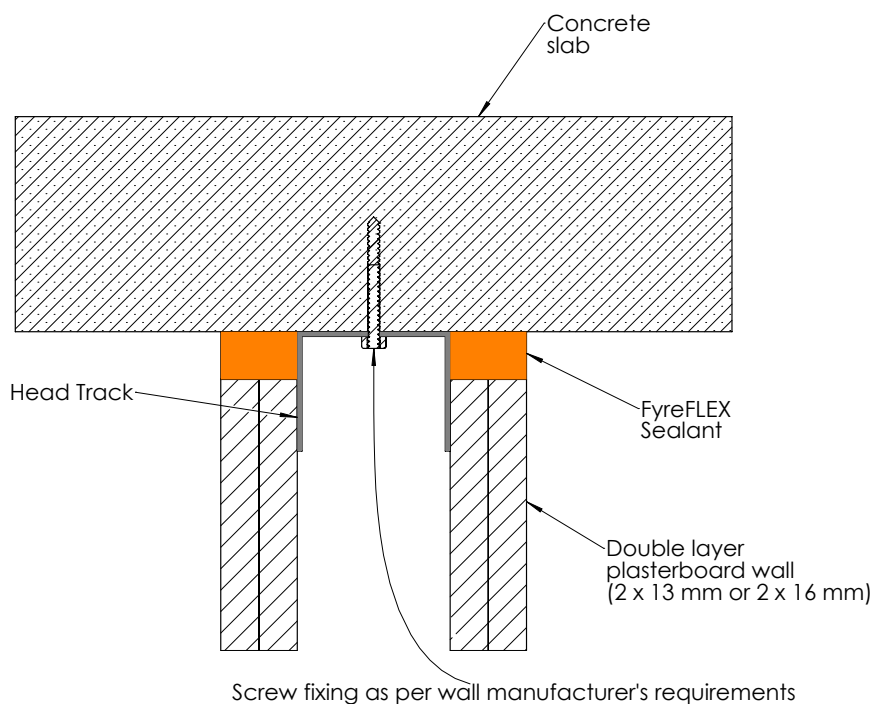

VERTICAL CONTROL JOINTS

PLASTERBOARD, CONCRETE/ MASONRY

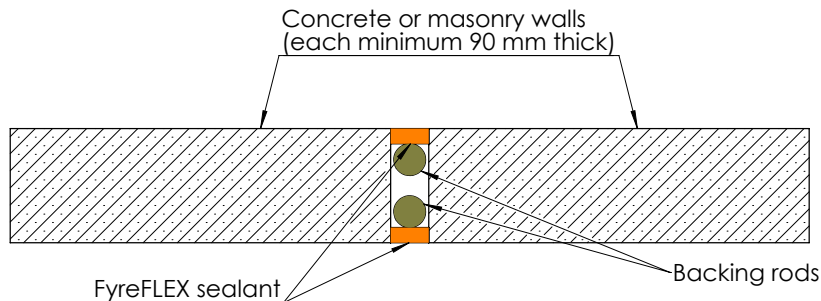

Top View

Wall System	Joint details	FRL
2 × 16 mm plasterboard on C-H stud with 25 mm shaft liner (minimum 96 mm thick)	Maximum 20 mm wide, 16 mm fill depth from both sides	-/120/90
2 × 13 mm or 2 × 16 mm plasterboard walls (minimum 116 mm thick)	Maximum 20 mm wide, full depth of plasterboard both sides	-/120/120
1 × 16 mm plasterboard walls (minimum 96 mm thick)	Maximum 20 mm wide, 16 mm fill depth from both sides	-/90/90
Solid masonry or concrete walls designed in accordance with AS 3700 or AS 3600 respectively, minimum 90 mm thick	Maximum 30 mm wide, 12 mm fill depth from both sides	-/120/120
Masonry or concrete walls designed in accordance with AS 3700 or AS 3600 respectively, minimum 140 mm thick	Maximum 20 mm wide, 30 mm fill depth from one side (Sealant placed on the unexposed side)	-/240/180 one-way FRL
	Maximum 20 mm wide, 30 mm fill depth from both sides	-/240/240

HORIZONTAL JOINTS IN BETWEEN CONCRETE SLABS

CONCRETE FLOORS

Wall System	Joint details	FRL
Concrete floor slabs designed to AS 3600 minimum thickness 175 mm	Maximum 40 mm wide, 40 mm fill depth from top side	-/240/120

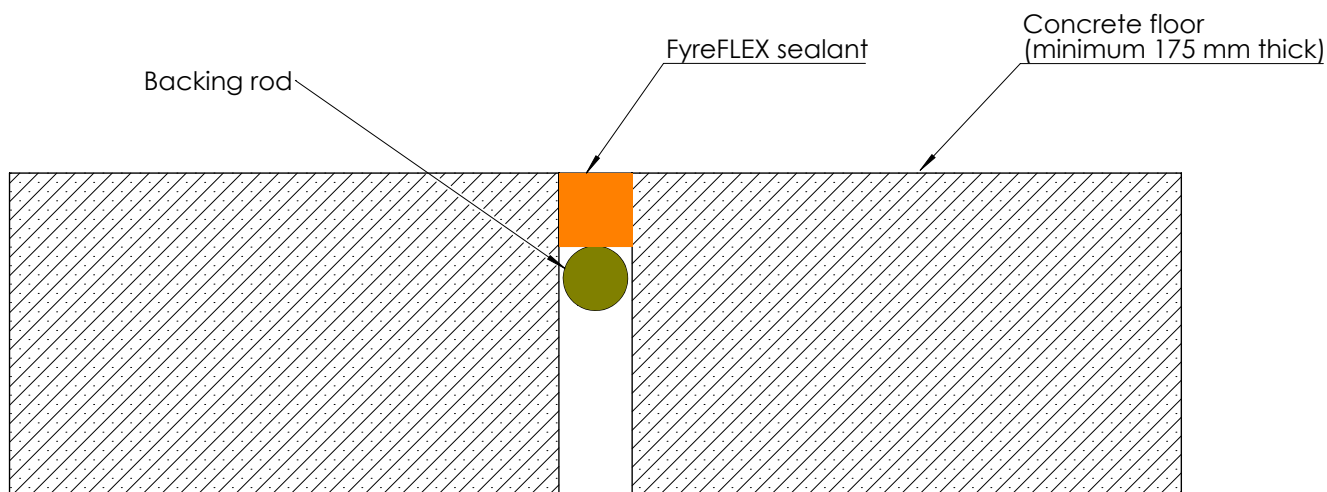

Front View

T-JOINTS BETWEEN TWO PERPENDICULAR WALLS

PLASTERBOARD, CONCRETE/ MASONRY

Wall System			FRL
Plasterboard to plasterboard walls:	2 × 13 mm or 2 × 16 mm plasterboard walls (minimum 116 mm thick)	Maximum 20 mm wide, full fill depth both sides	-/120/120
	1 × 16 mm plasterboard walls (minimum 96 mm thick)		-/90/90
Rigid to Rigid walls:	Concrete / solid masonry to concrete / solid masonry walls (90 mm thick)	Maximum 30 mm, 12 mm fill depth from both sides	-/120/120
	Concrete / solid masonry to concrete / solid masonry walls (140 mm thick)	Maximum 20 mm, 30 mm fill depth from both sides	-/240/240
Plasterboard to rigid walls (minimum 90 mm thick):	2 × 13 mm or 2 × 16 mm plasterboard walls (minimum 116 mm thick)	Maximum 20 mm wide, full fill depth both sides	-/120/120
	1 × 16 mm plasterboard walls (minimum 96 mm thick)		-/90/90

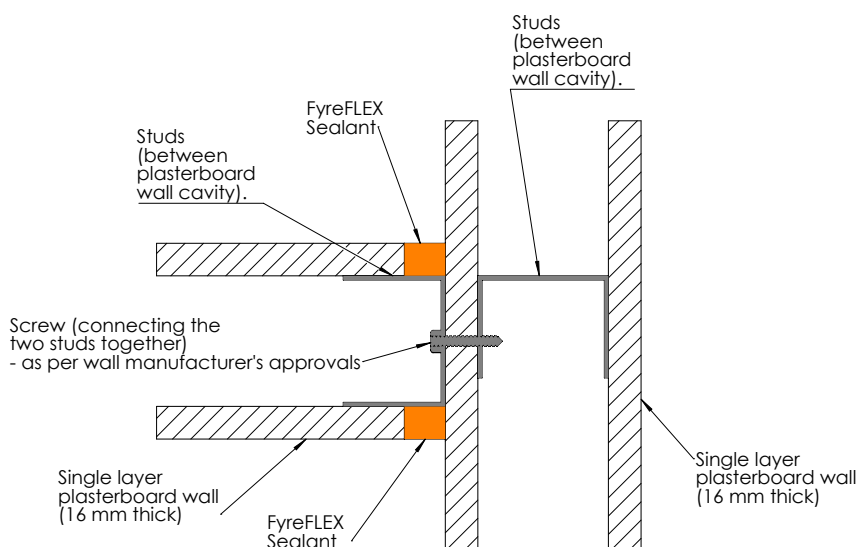

INSTALLATION

PLASTERBOARD WALLS



STEP 1- PREPARE



Clean the penetration so it is free from dust, dirt oil etc.

STEP 2- BACKING RODS



Install a sacrificial foam backing rod (can be PE or other materials) into the joint to set the correct depth of the joint.

Foam backing rods (combustible or otherwise) can be used to ensure sealant is filled to the correct depth.

STEP 3- TOOLS



FyreFLEX is available in a 300ml cartridge, 600ml sausage both of which can be pumped with standard manual and electric powered sealant guns to suit.

FyreFLEX is also available in a 10L pail where bulk caulking guns can be used for a more environmental approach.

STEP 4- APPLY SEALANT

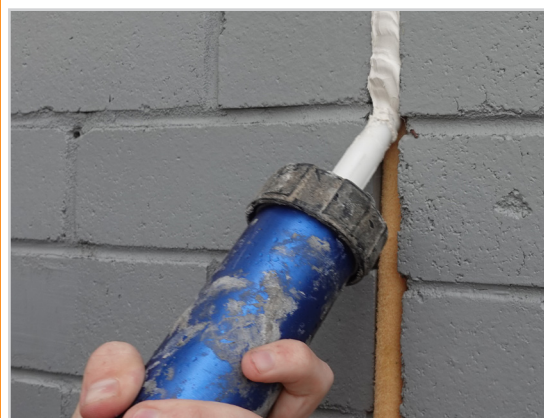

Fill the control joint with FyreFLEX sealant as per the FRL tables on pages 7-10. Ensure that the joint width does not exceed the tested/approved size. Finish the sealant with a soapy cloth or shim to get the desired flush finish.

Refer to installation drawings at the end of this manual.

SYSTEM RANGE



Item Number	Description	Min Order Qty	Pallet QTY
FyreFLEX 300W FyreFLEX 300G	FyreFLEX® sealant Cartridge 300ml White or Grey	25	1600
FyreFLEX 600W FyreFLEX 600G	FyreFLEX® sealant Sausage 600ml White or Grey	20	1440
FyreFLEX 10G	FyreFLEX® sealant Pail 10L- Grey	1	110

Item Number	Description	Min Order Qty	Pallet QTY
Backing Rod – 16mm x 150m	Backing Rod- Diameter 16mm, Length 150m	1x	N/a
Backing Rod – 22mm x 100m	Backing Rod- Diameter 22mm, Length 100m	1x	N/a
Backing Rod – 29mm x 60m	Backing Rod- Diameter 29mm, Length 60m	1x	N/a
Backing Rod – larger diameters upon request	-	1x	N/a

* FyreWrap® can be substituted for TWRAP™

SYSTEM RANGE

For Bigger and Higher Movement Joints See Our Ryan Fire Control Joint Systems

RYANSPAN

Click here to learn more

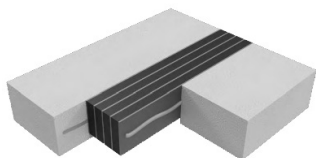

Concrete Slabs

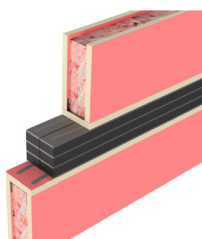

Plasterboard 120 mins

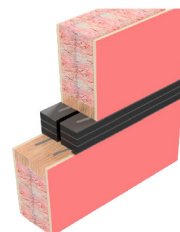

Plasterboard 60 mins

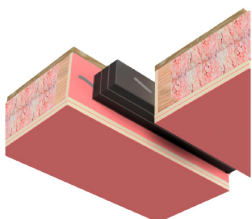

Plasterboard Ceilings

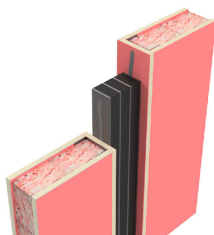

Plasterboard Vertical

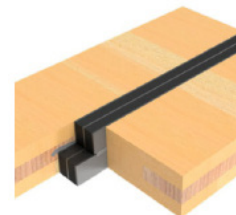

CLT

FAQ

Q Do I need to use a backing rod?

A While they are not required, it is recommended that they be used in order to correctly set the depth of the sealant fill.

Q Can I use PE backing Rod?

A Yes, PE backing rods can be used.

Q What is the difference between white and grey FyreFLEX, can I use either?

A Yes, the different colours have the same performance and can be used interchangeably.

Q Can I paint over the sealant?

A Yes the sealant can be painted over, please wait at least 24 hours for the sealant to dry before painting.

Q Can FyreFLEX Sealant be used externally (in the weather)?

A Yes, however we recommend covering with a polyurethane sealant to protect the seal from the elements.

Q Can FyreFLEX Sealant handle and movement?

A Yes, FyreFLEX has a 10% movement capacity.

SOCIAL MEDIA

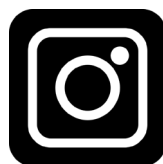

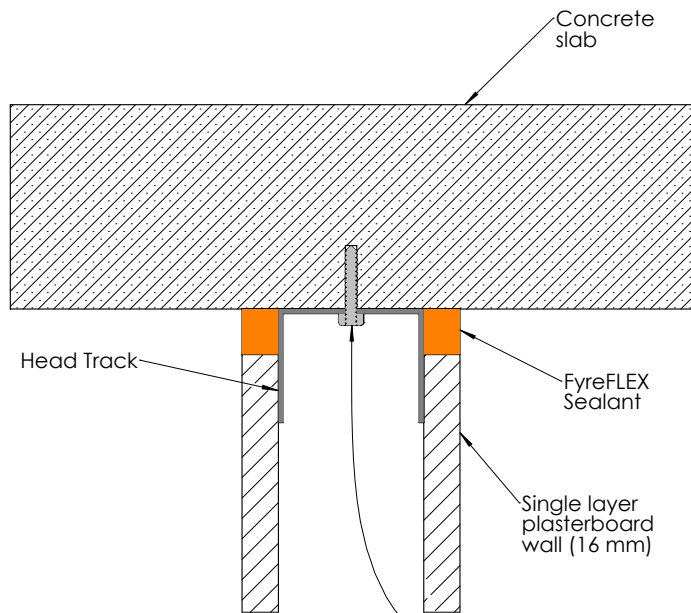

Screw fixing as per wall manufacturer's requirements

Head of wall control joint
(between single layer
plasterboard wall
and concrete slab)

FRL: -/90/90

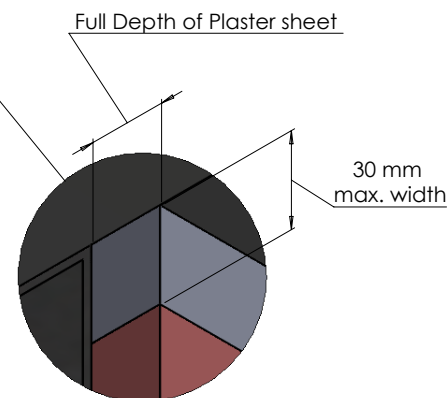
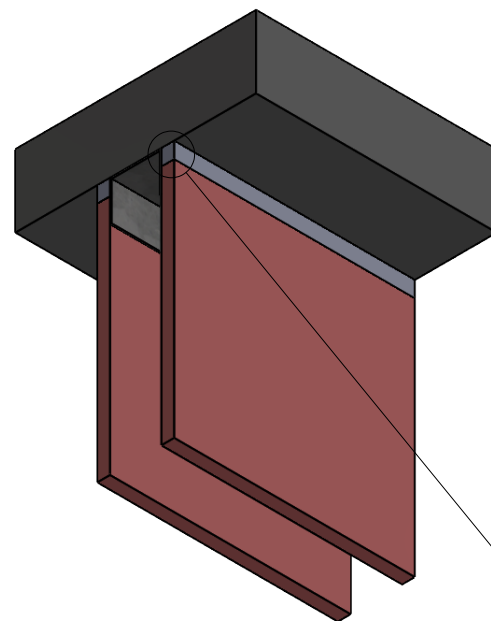

FyreFLEX
sealant

Note: Also applies to concrete/masonry walls

Drawing Name: Plasterboard (Single-layer)				Test Standard: AS1530.4	Codes:	Revision:	Date:	No.:	NOTICE:
Project Title: Head of wall control joint drawings				Fire resistance level:	Drawn By: MI	<small>NOTE: ALL DIMENSIONS ARE IN MILLIMETRES (mm)</small>			
Drawing No. : 1	Sheet: 1 of 4	Date: 14/08/2023	Scale: NTS	Based on Report No.: FAS210386	Checked By: JH	<input type="checkbox"/> STANDARD DRAWING	 <p>TRAFALGAR FIRE PO BOX 545 Chester Hill NSW 2162 T: 1800 888 714 F: 1800 201 500 E: technical@tgroup.com.au W: www.fire.com.au</p>		
						<input type="checkbox"/> PROJECT DRAWING			

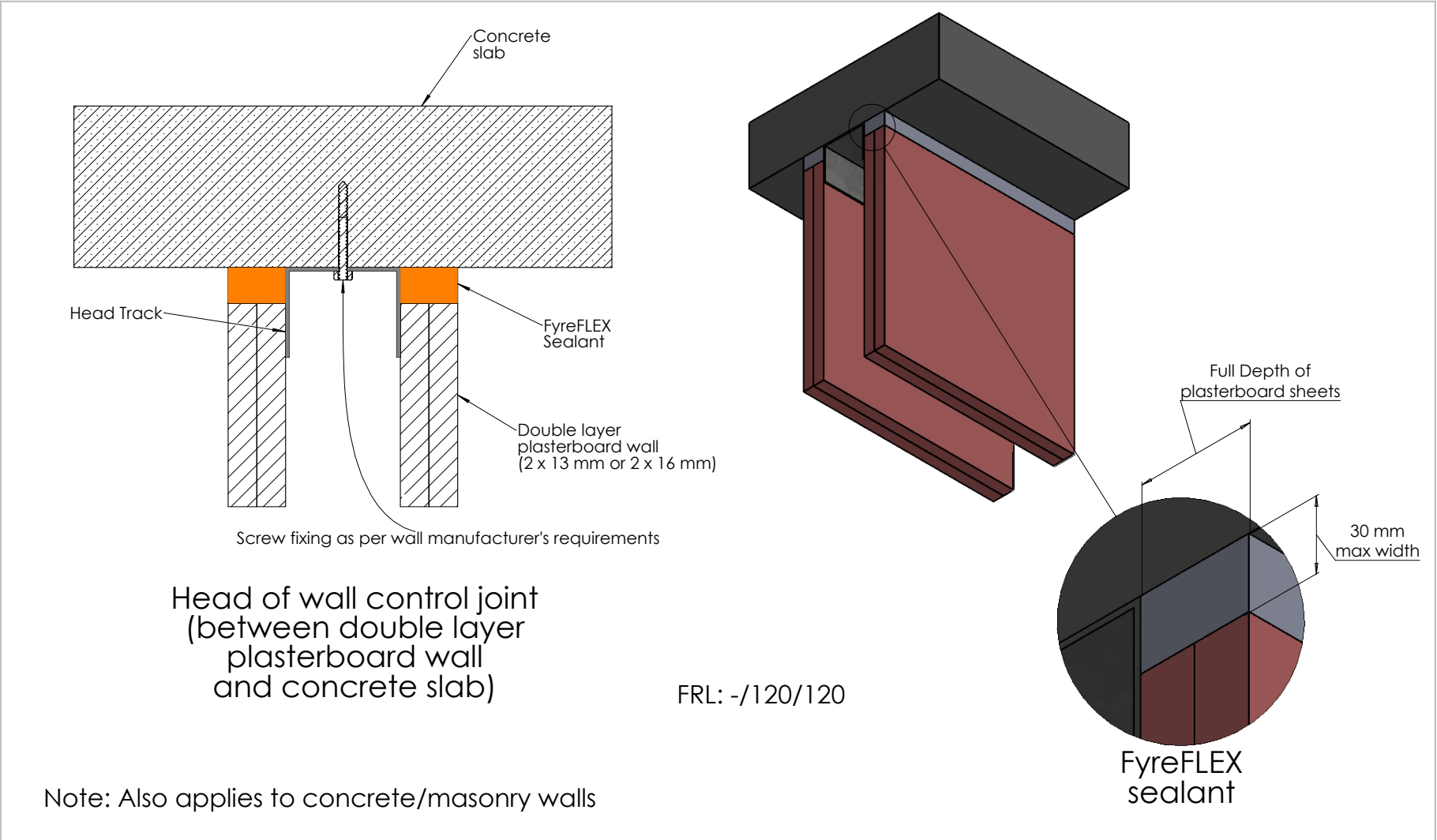

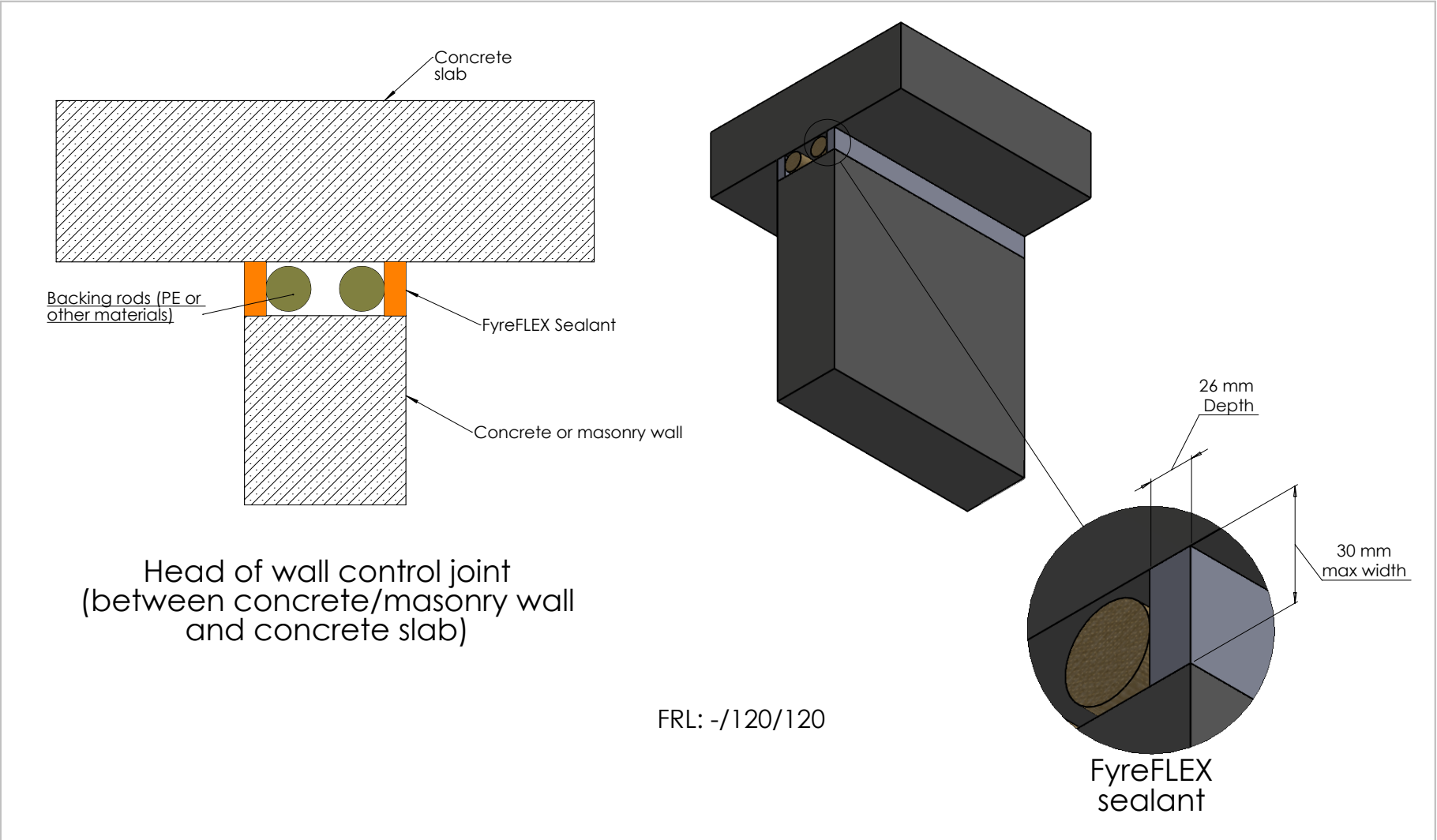

Note: Also applies to concrete/masonry walls

Drawing Name: Plasterboard (Double-layer)				Test Standard: AS1530.4	Codes:	Revision:	Date:	No.:	NOTICE:
Project Title: Head of wall control joint drawings				Fire resistance level:	Drawn By: MI	<small>NOTE: ALL DIMENSIONS ARE IN MILLIMETRES (mm)</small>			
Drawing No. : 2	Sheet: 2 of 4	Date: 14/08/2023	Scale: NTS	Based on Report No.: FAS210386	Checked By: JH	<input type="checkbox"/> STANDARD DRAWING	 <p>TRAFALGAR FIRE PO BOX 545 Chester Hill NSW 2162 T: 1800 888 714 F: 1800 201 500 E: technical@tgroup.com.au W: www.fire.com.au</p>		
						<input type="checkbox"/> PROJECT DRAWING			

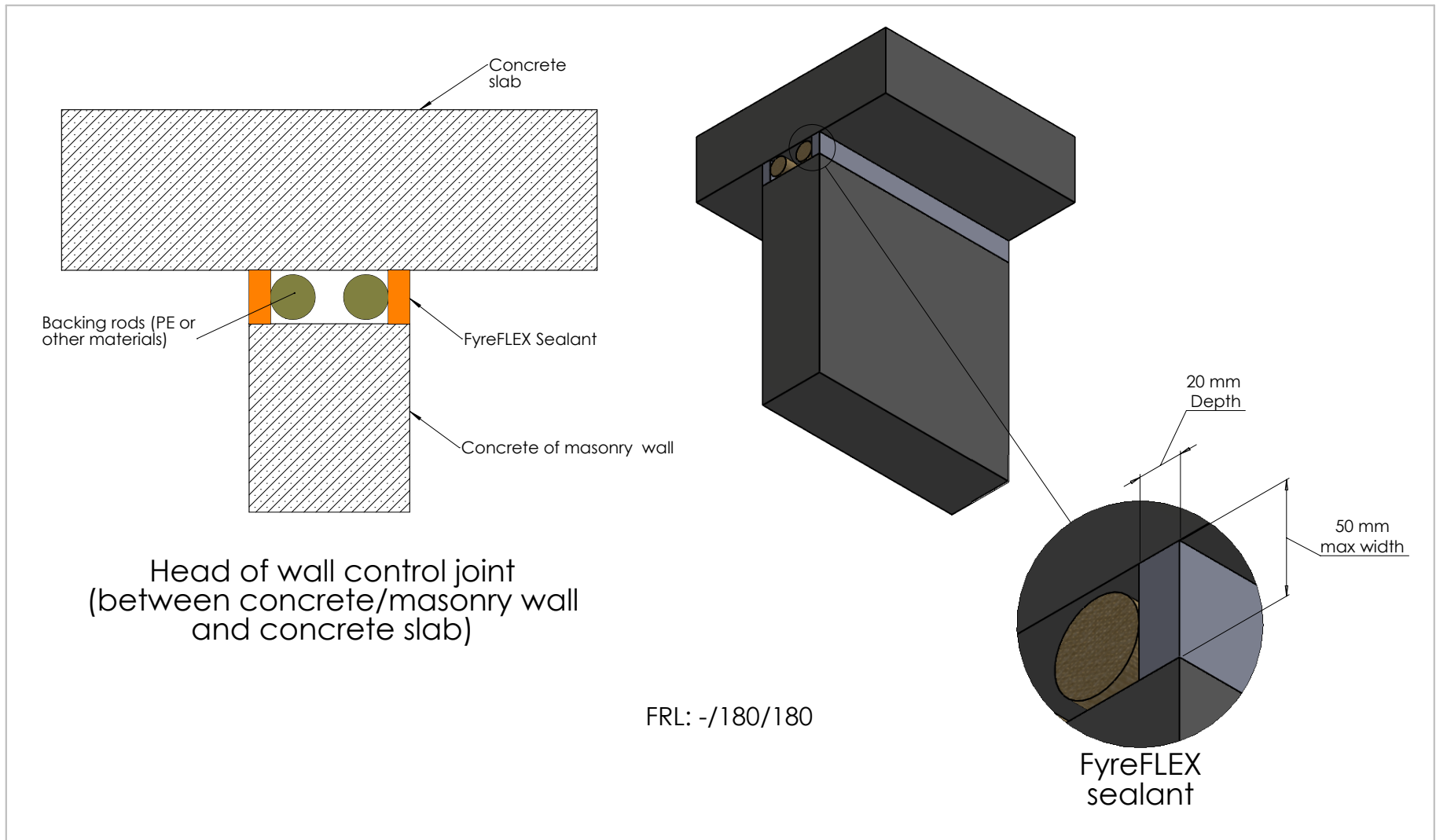

Drawing Name: Concrete or masonry wall (116 mm)		Test Standard: AS1530.4	Codes:	Revision:	Date:	No.:	NOTICE:
Project Title: Head of wall control joint drawings		Fire resistance level:	Drawn By: MI	<small>NOTE: ALL DIMENSIONS ARE IN MILLIMETRES (mm)</small>			
Drawing No. : 3	Sheet: 3 of 4	Date: 14/08/2023	Scale: NTS	Based on Report No.: FAS210386	Checked By: JH	<input type="checkbox"/> STANDARD DRAWING <input type="checkbox"/> PROJECT DRAWING	Trafalgar Head Office: PO BOX 545 Chester Hill NSW 2162 T: 1800 888 714 F: 1800 201 500 E: technical@tgroup.com.au W: www.tfire.com.au



Drawing Name: Concrete or masonry wall (140 mm thick)				Test Standard: AS1530.4	Codes:	Revision:	Date:	No.:	NOTICE:
Project Title: Head of wall control joint drawings				Fire resistance level:	Drawn By: MI	<small>NOTE: ALL DIMENSIONS ARE IN MILLIMETRES (mm)</small>			
Drawing No. : 4	Sheet: 4 of 4	Date: 14/08/2023	Scale: NTS	Based on Report No.: FAS210386	Checked By: JH	<input type="checkbox"/> STANDARD DRAWING	 <p>TRAFALGAR FIRE PO BOX 545 Chester Hill NSW 2162 T: 1800 888 714 F: 1800 201 500 E: technical@tgroup.com.au W: www.fire.com.au</p>		
						<input type="checkbox"/> PROJECT DRAWING			

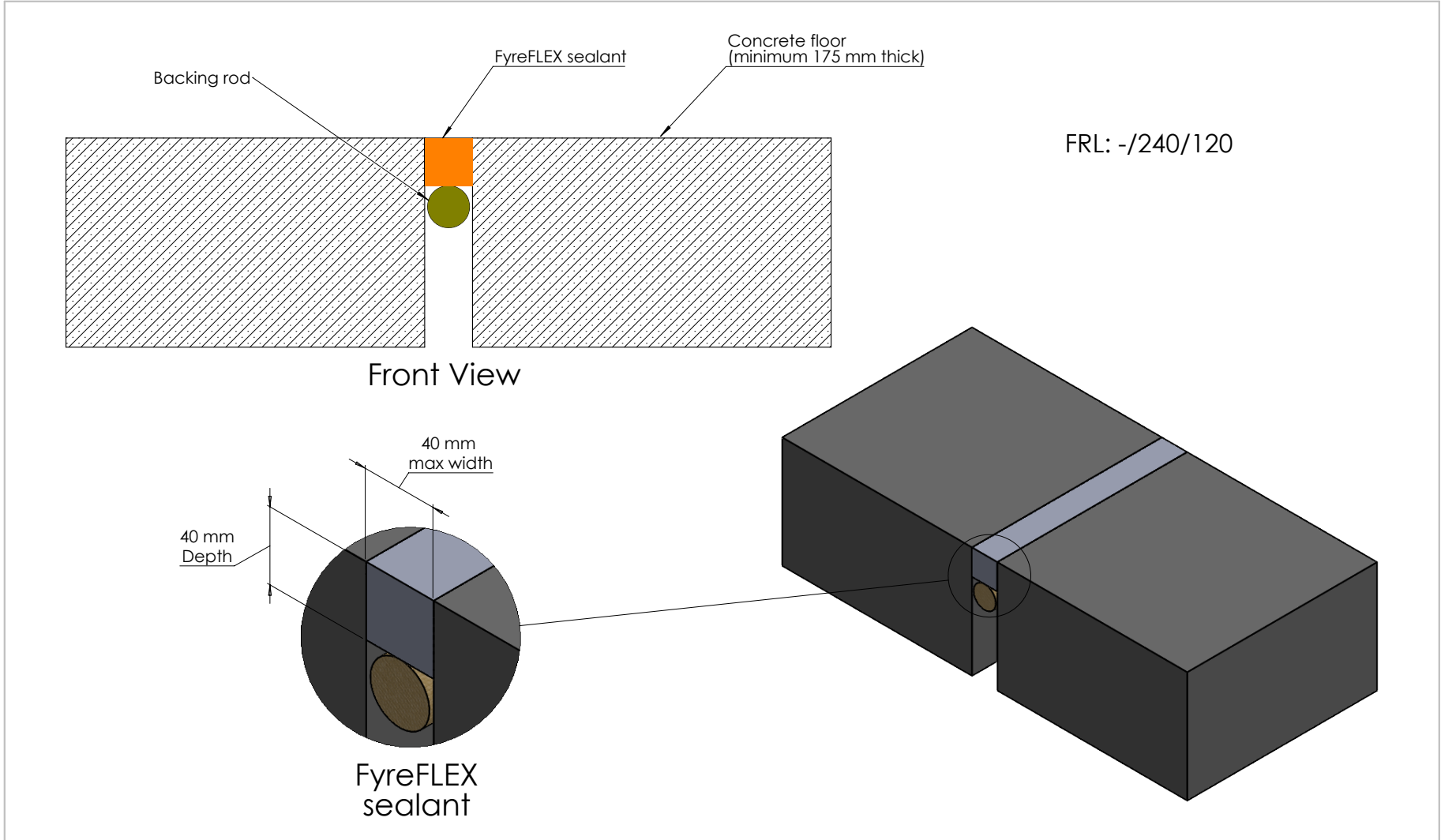

Drawing Name: Concrete floor slabs			Test Standard: AS1530.4	Codes:	Revision:	Date:	No.:	NOTICE:
Project Title: Horizontal control joints drawing			Fire resistance level:	Drawn By: MI	<small>NOTE: ALL DIMENSIONS ARE IN MILLIMETRES (mm)</small>			
Drawing No. : 1	Sheet: 1 of 1	Date: 14/08/2023	Scale: NTS	Based on Report No.: FAS210386	Checked By: JH	<input type="checkbox"/> STANDARD DRAWING <input type="checkbox"/> PROJECT DRAWING		TRAFALGAR FIRE PO BOX 545 Chester Hill NSW 2162 T: 1800 888 714 F: 1800 201 500 E: technical@tgroup.com.au W: www.fire.com.au

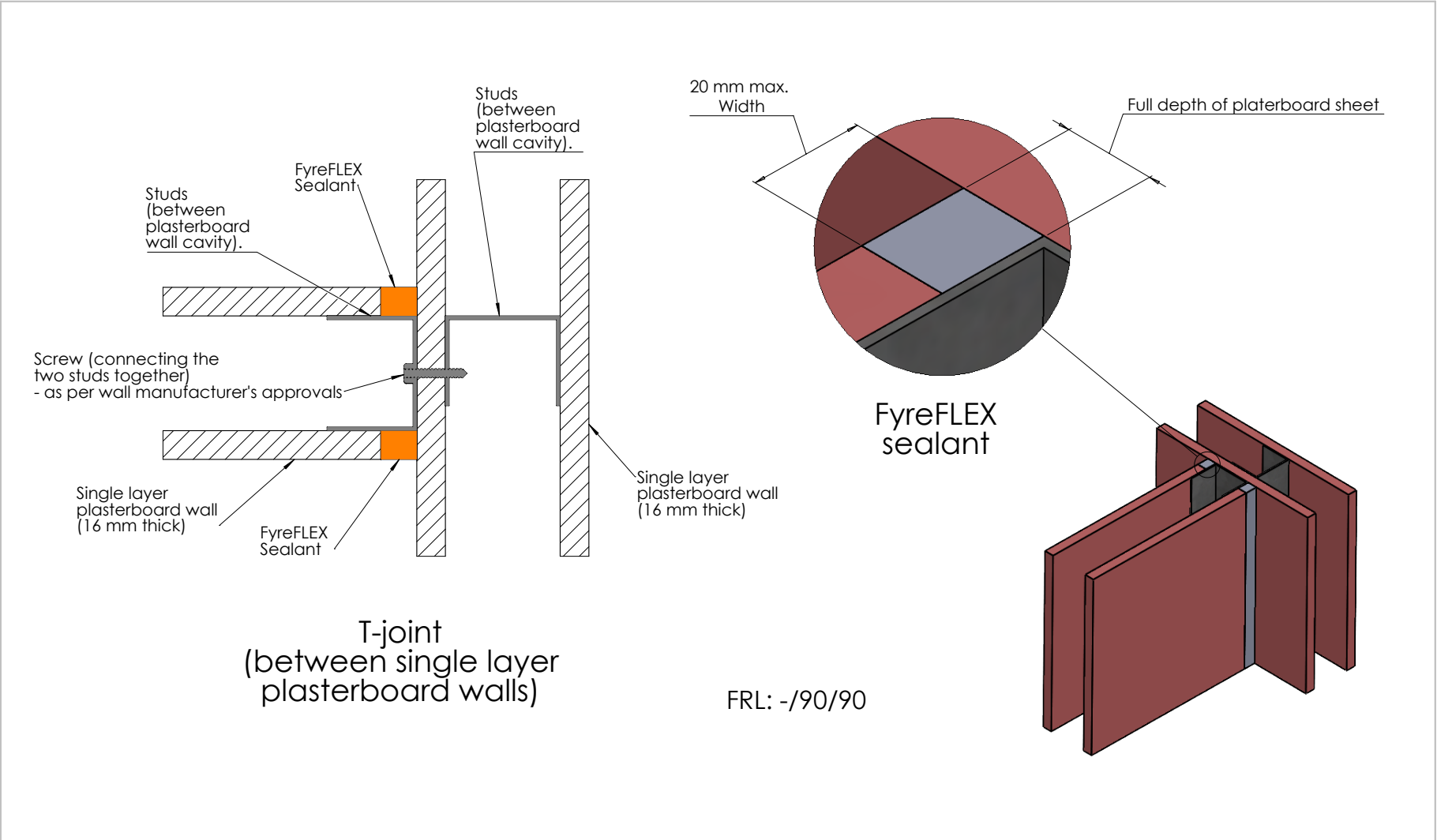

Drawing Name: T-joint: both plasterboard (single layer)				Test Standard: AS1530.4	Codes:	Revision:	Date:	No.:	NOTICE:
Project Title: T-joint drawings				Fire resistance level:	Drawn By: MI	<small>NOTE: ALL DIMENSIONS ARE IN MILLIMETRES (mm)</small>			
Drawing No. : 1	Sheet: 1 of 7	Date: 14/08/2023	Scale: NTS	Based on Report No.: FAS210386	Checked By: JH	<input type="checkbox"/> STANDARD DRAWING	 <p>TRAFALGAR FIRE PO BOX 545 Chester Hill NSW 2162 T: 1800 888 714 F: 1800 201 500 E: technical@tgroup.com.au W: www.fire.com.au</p>		
						<input type="checkbox"/> PROJECT DRAWING			

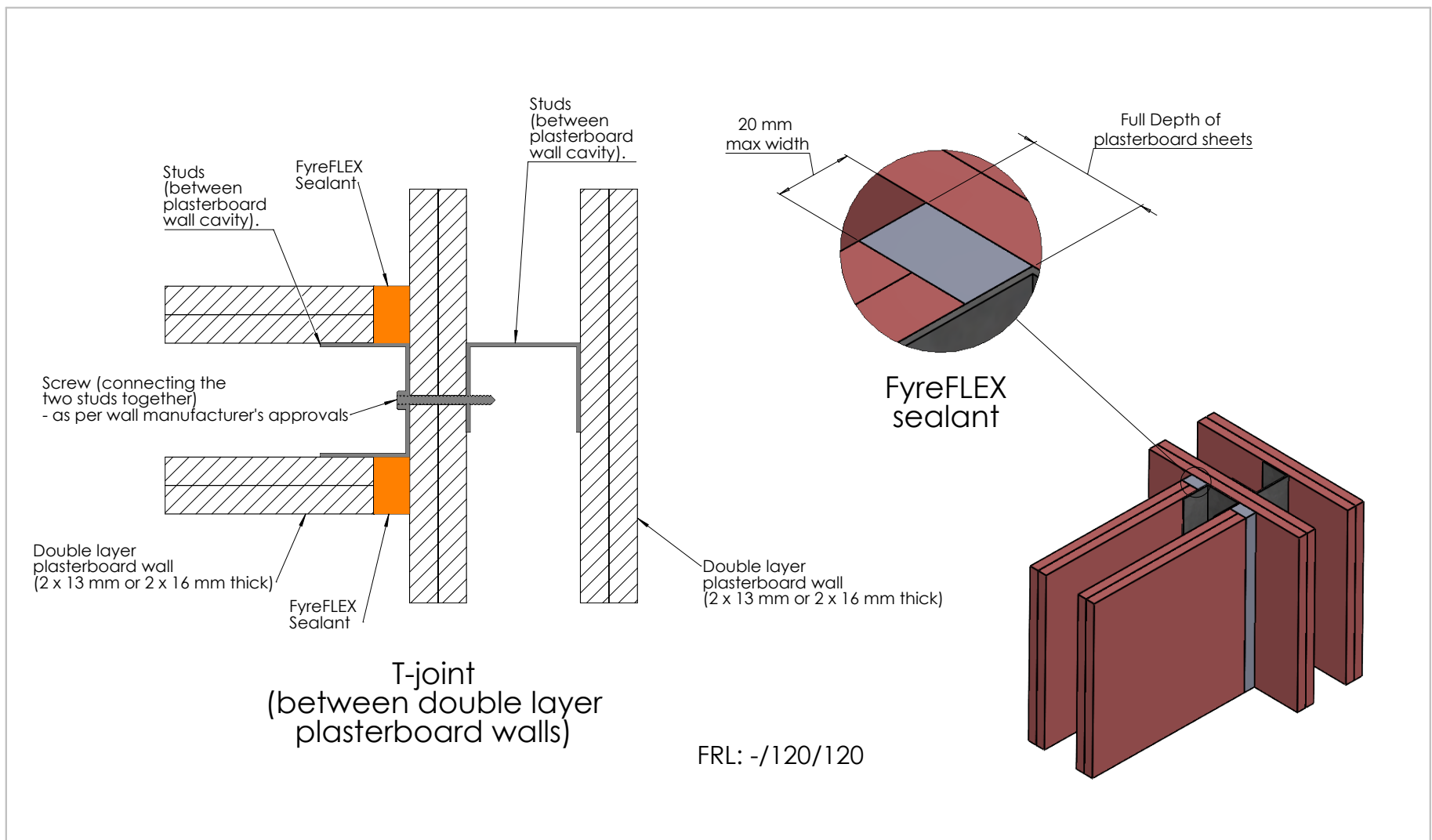

Drawing Name: T-Joint: both plasterboard walls (double layer)				Test Standard: AS1530.4	Codes:	Revision:	Date:	No.:	NOTICE:
Project Title: T-joint drawings				Fire resistance level:	Drawn By: MI	<small>NOTE: ALL DIMENSIONS ARE IN MILLIMETRES (mm)</small>			
Drawing No. : 2	Sheet: 2 of 7	Date: 14/08/2023	Scale: NTS	Based on Report No.: FAS210386	Checked By: JH	<input type="checkbox"/> STANDARD DRAWING	 <p>TRAFALGAR FIRE</p> <p>PO BOX 545 Chester Hill NSW 2162 T: 1800 888 714 F: 1800 201 500 E: technical@tgroup.com.au W: www.fire.com.au</p>		
						<input type="checkbox"/> PROJECT DRAWING			

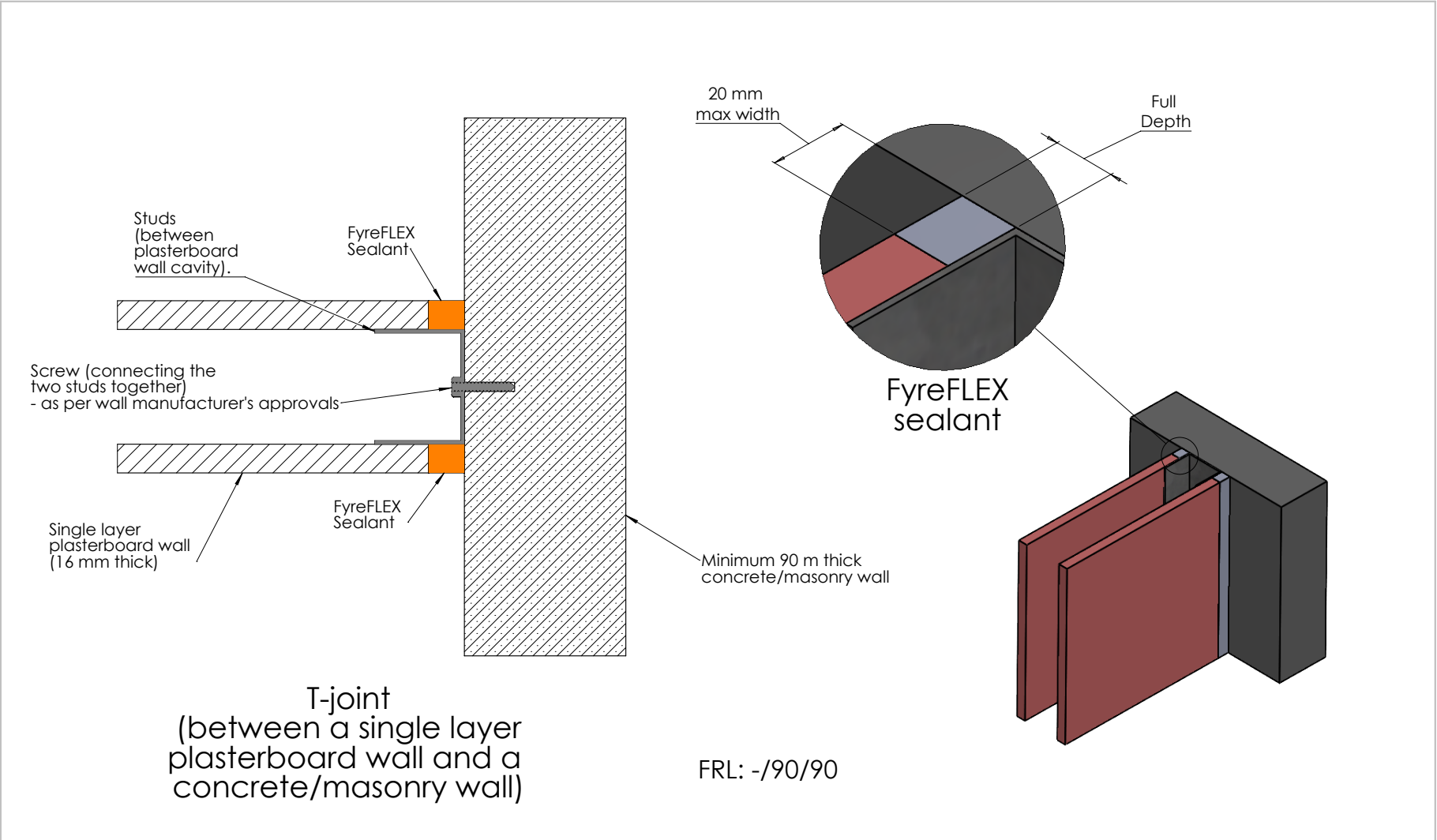

Drawing Name: T-Joints: Plasterboard wall (single layer) to concrete/masonry wall			Test Standard: AS1530.4	Codes:	Revision:	Date:	No.:	NOTICE:
Project Title: T-joint drawings			Fire resistance level:	Drawn By: MI	<small>NOTE: ALL DIMENSIONS ARE IN MILLIMETRES (mm)</small>			
Drawing No. : 3	Sheet: 3 of 7	Date: 14/08/2023	Scale: NTS	Based on Report No.: FAS210386	Checked By: JH	<input type="checkbox"/> STANDARD DRAWING <input type="checkbox"/> PROJECT DRAWING		Trafalgar Head Office: PO BOX 545 Chester Hill NSW 2162 T: 1800 888 714 F: 1800 201 500 E: technical@tgroup.com.au W: www.tfire.com.au

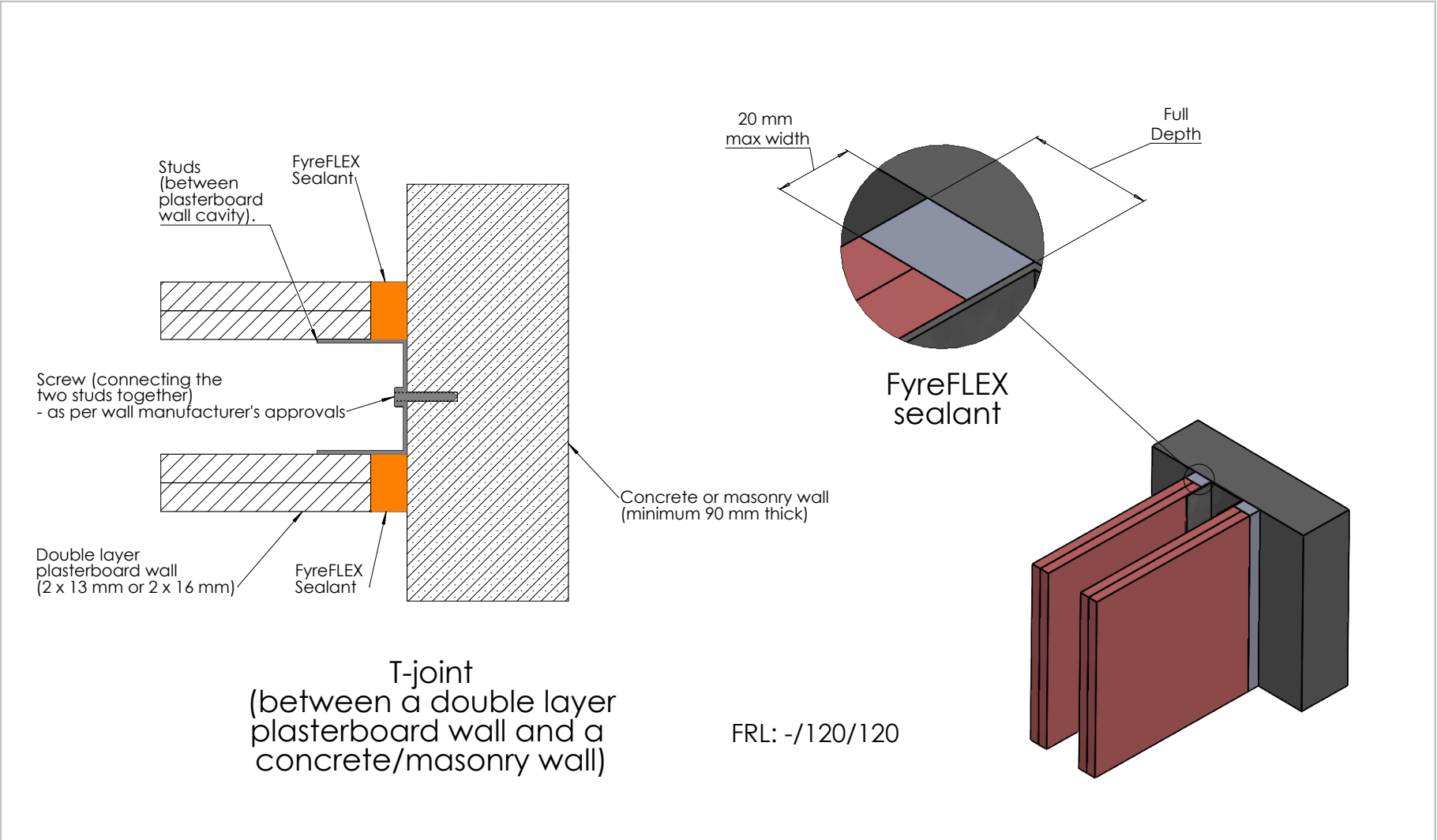

Drawing Name: T-Joints: Plasterboard wall (double layer) to concrete/masonry wall		Test Standard: AS1530.4	Codes:	Revision:	Date:	No.:	NOTICE:
Project Title: T-joint drawings		Fire resistance level:	Drawn By: MI	<small>NOTE: ALL DIMENSIONS ARE IN MILLIMETRES (mm)</small>			
Drawing No. : 4	Sheet: 4 of 7	Date: 14/08/2023	Scale: NTS	Based on Report No.: FAS210386	Checked By: JH	<input type="checkbox"/> STANDARD DRAWING <input type="checkbox"/> PROJECT DRAWING	

TRAFALGAR FIRE

Trafalgar Head Office:
PO BOX 545
Chester Hill NSW 2162
T: 1800 888 714
F: 1800 201 500
E: technical@tgroup.com.au
W: www.fire.com.au

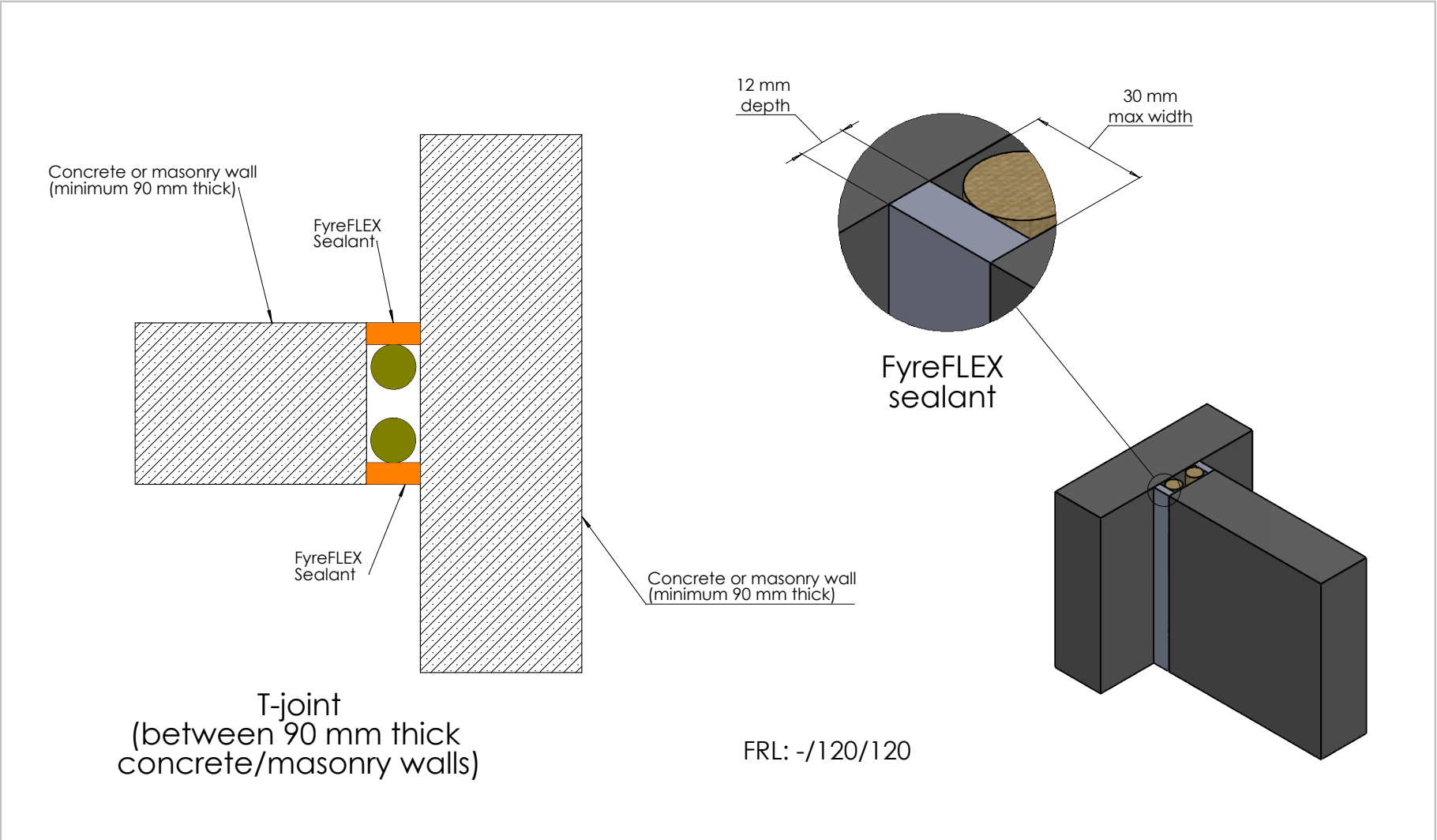

Drawing Name: T-Joints: Concrete/Masonry wall to Concrete/Masonry wall (90 mm thick)		Test Standard: AS1530.4	Codes:	Revision:	Date:	No.:	NOTICE:
Project Title: T-joint drawings		Fire resistance level:	Drawn By: MI	<small>NOTE: ALL DIMENSIONS ARE IN MILLIMETRES (mm)</small>			
Drawing No. : 5	Sheet: 5 of 7	Date: 14/08/2023	Scale: NTS	Based on Report No.: FAS210386	Checked By: JH	<input type="checkbox"/> STANDARD DRAWING <input type="checkbox"/> PROJECT DRAWING	TRAFALGAR FIRE <small>Trafalgar Head Office: PO BOX 545 Chester Hill NSW 2162 T: 1800 888 714 F: 1800 201 500 E: technical@tgroup.com.au W: www.fire.com.au</small>

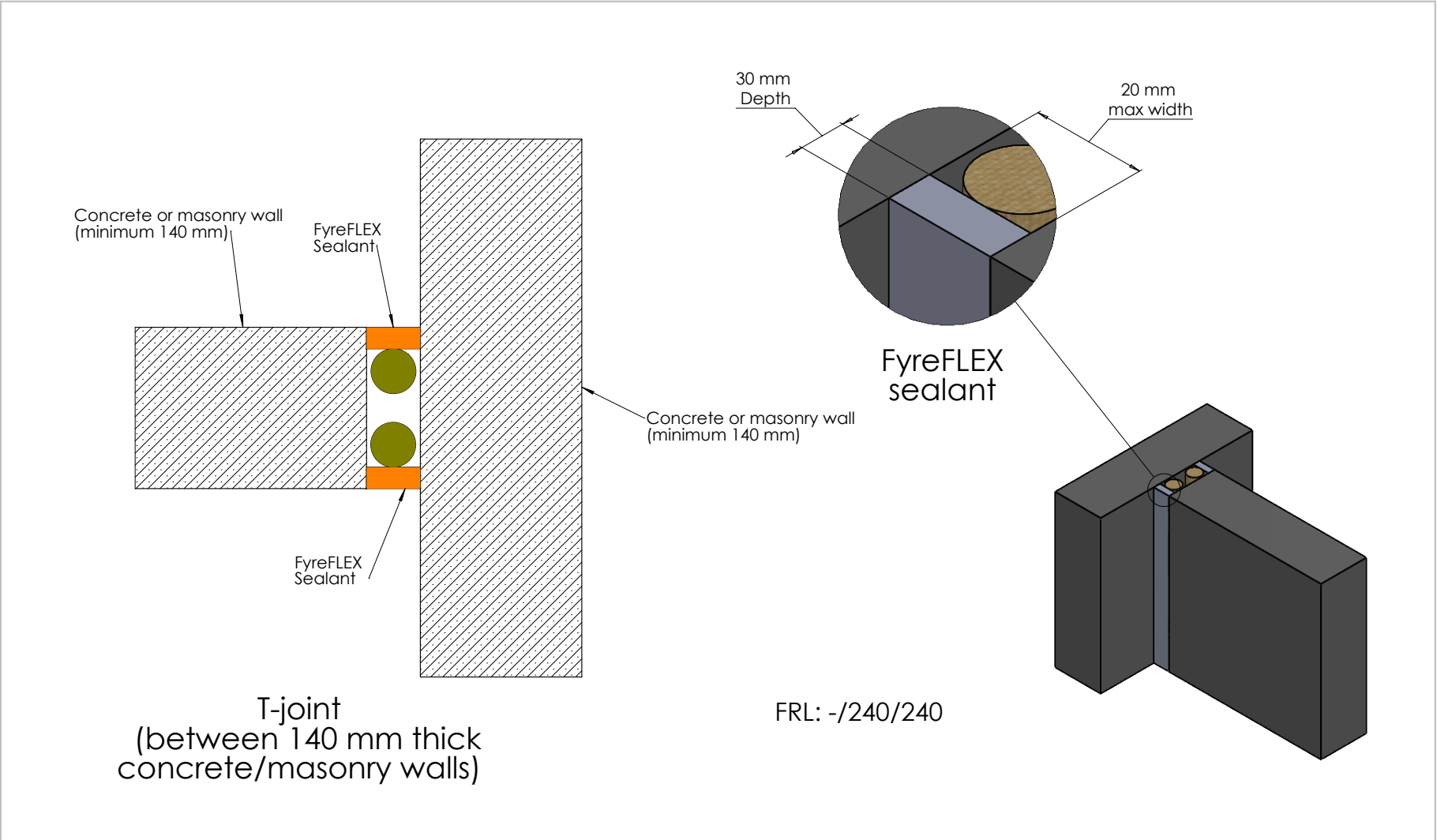

Drawing Name: T-Joints: Concrete/Masonry wall to Concrete/Masonry wall (140 mm thick)			Test Standard: AS1530.4	Codes:	Revision:	Date:	No.:	NOTICE:
Project Title: T-joint drawings			Fire resistance level:	Drawn By: MI	<small>NOTE: ALL DIMENSIONS ARE IN MILLIMETRES (mm)</small>			
Drawing No. : 6	Sheet: 6 of 7	Date: 14/08/2023	Scale: NTS	Based on Report No.: FAS210386	Checked By: JH	<input type="checkbox"/> STANDARD DRAWING <input type="checkbox"/> PROJECT DRAWING		TRAFALGAR FIRE <small>Trafalgar Head Office: PO BOX 545 Chester Hill NSW 2162 T: 1800 888 714 F: 1800 201 500 E: technical@tgroup.com.au W: www.tfire.com.au</small>

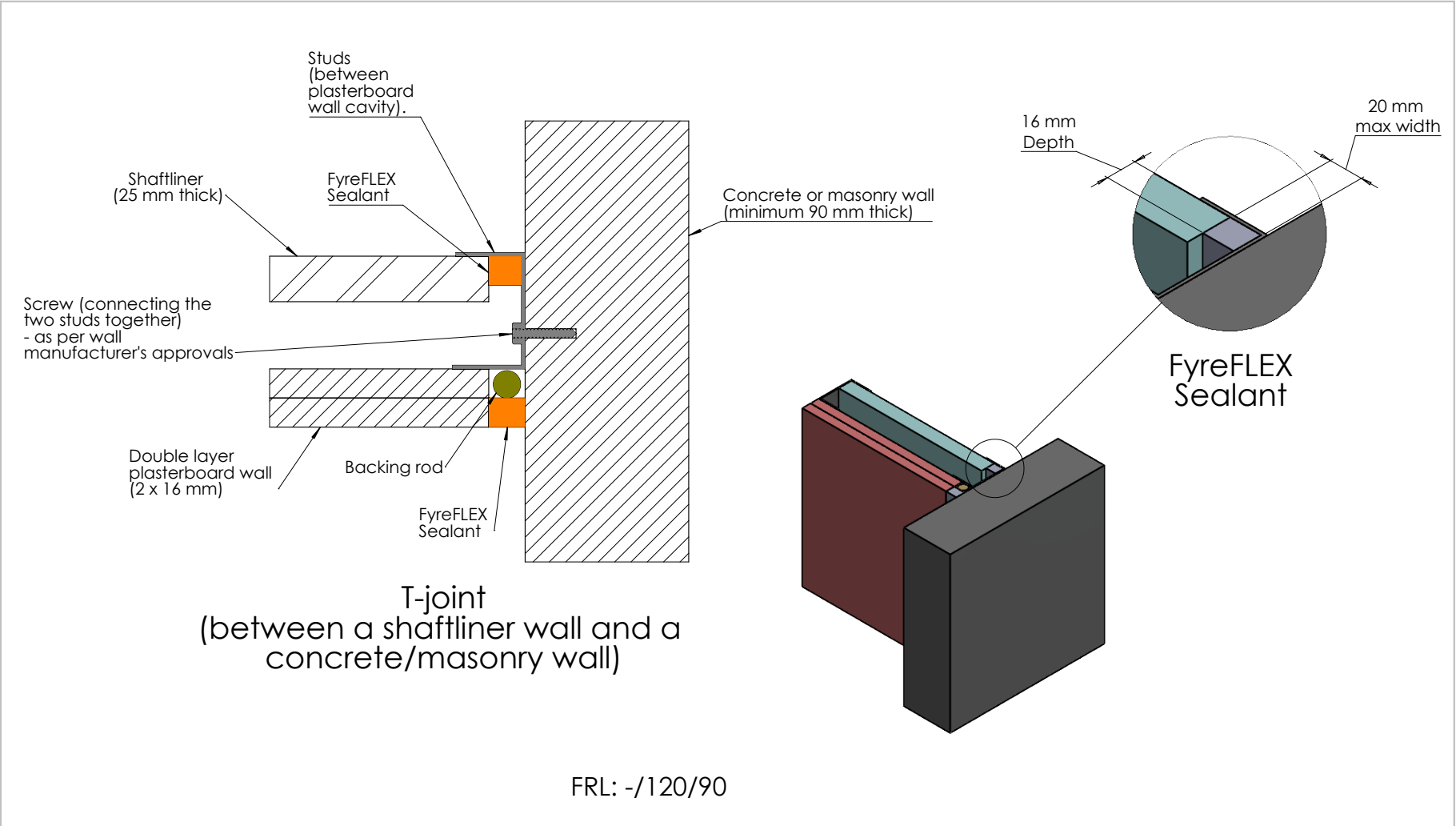

Drawing Name: T-Joints: Shaftliner wall to concrete/masonry wall			Test Standard: AS1530.4	Codes:	Revision:	Date:	No.:	NOTICE:
Project Title: T-joint drawings			Fire resistance level:	Drawn By: MI	<small>NOTE: ALL DIMENSIONS ARE IN MILLIMETRES (mm)</small>			
Drawing No. : 7	Sheet: 7 of 7	Date: 14/08/2023	Scale: NTS	Based on Report No.: FAS210386	Checked By: JH	<input type="checkbox"/> STANDARD DRAWING <input type="checkbox"/> PROJECT DRAWING		TRAFALGAR FIRE <small>PO BOX 545 Chester Hill NSW 2162 T: 1800 888 714 F: 1800 201 500 E: technical@tgroup.com.au W: www.fire.com.au</small>

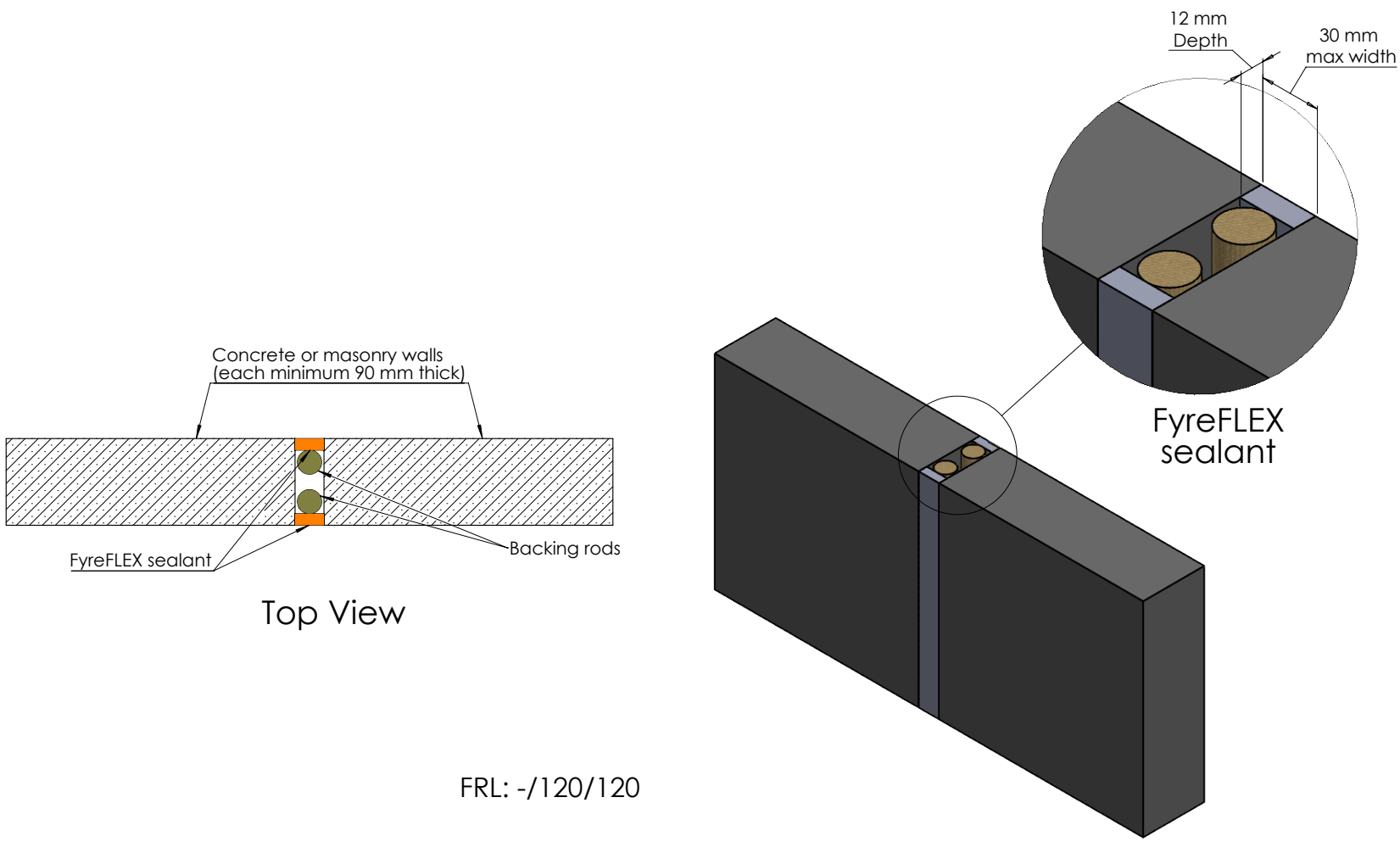

Drawing Name: Concrete/Masonry wall (with 30 mm wide control joint)		Test Standard: AS1530.4	Codes:	Revision:	Date:	No.:	NOTICE:
Project Title: Vertical control joints drawings		Fire resistance level:	Drawn By: MI	<small>NOTE: ALL DIMENSIONS ARE IN MILLIMETRES (mm)</small>			
Drawing No. : 1	Sheet: 1 of 6	Date: 14/08/2023	Scale: NTS	Based on Report No.: FAS210386	Checked By: JH	<input type="checkbox"/> STANDARD DRAWING	<input type="checkbox"/> PROJECT DRAWING

TRAFALGAR FIRE

Trafalgar Head Office:
PO BOX 545
Chester Hill NSW 2162
T: 1800 888 714
F: 1800 201 500
E: technical@tgroup.com.au
W: www.fire.com.au

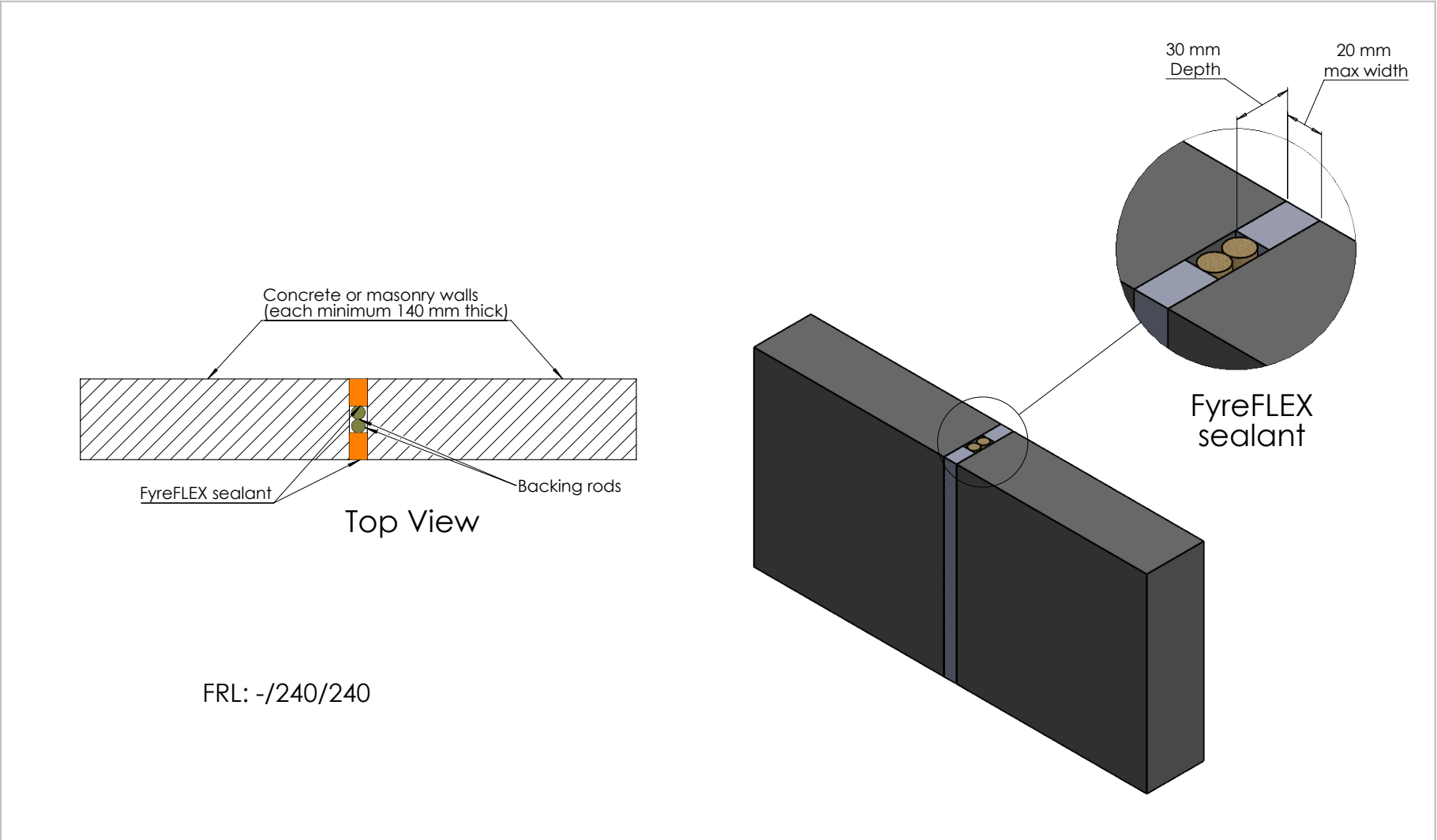

Drawing Name: Concrete/Masonry wall (with 20 mm wide control joint, for a two-way FRL)			Test Standard: AS1530.4	Codes:	Revision:	Date:	No.:	NOTICE:
Project Title: Vertical control joints drawings			Fire resistance level:	Drawn By: MI	<small>NOTE: ALL DIMENSIONS ARE IN MILLIMETRES (mm)</small>			
Drawing No. : 2	Sheet: 2 of 6	Date: 14/08/2023	Scale: NTS	Based on Report No.: FAS210386	Checked By: JH	<input type="checkbox"/> STANDARD DRAWING <input type="checkbox"/> PROJECT DRAWING		Trafalgar Head Office: PO BOX 545 Chester Hill NSW 2162 T: 1800 888 714 F: 1800 201 500 E: technical@tgroup.com.au W: www.fire.com.au

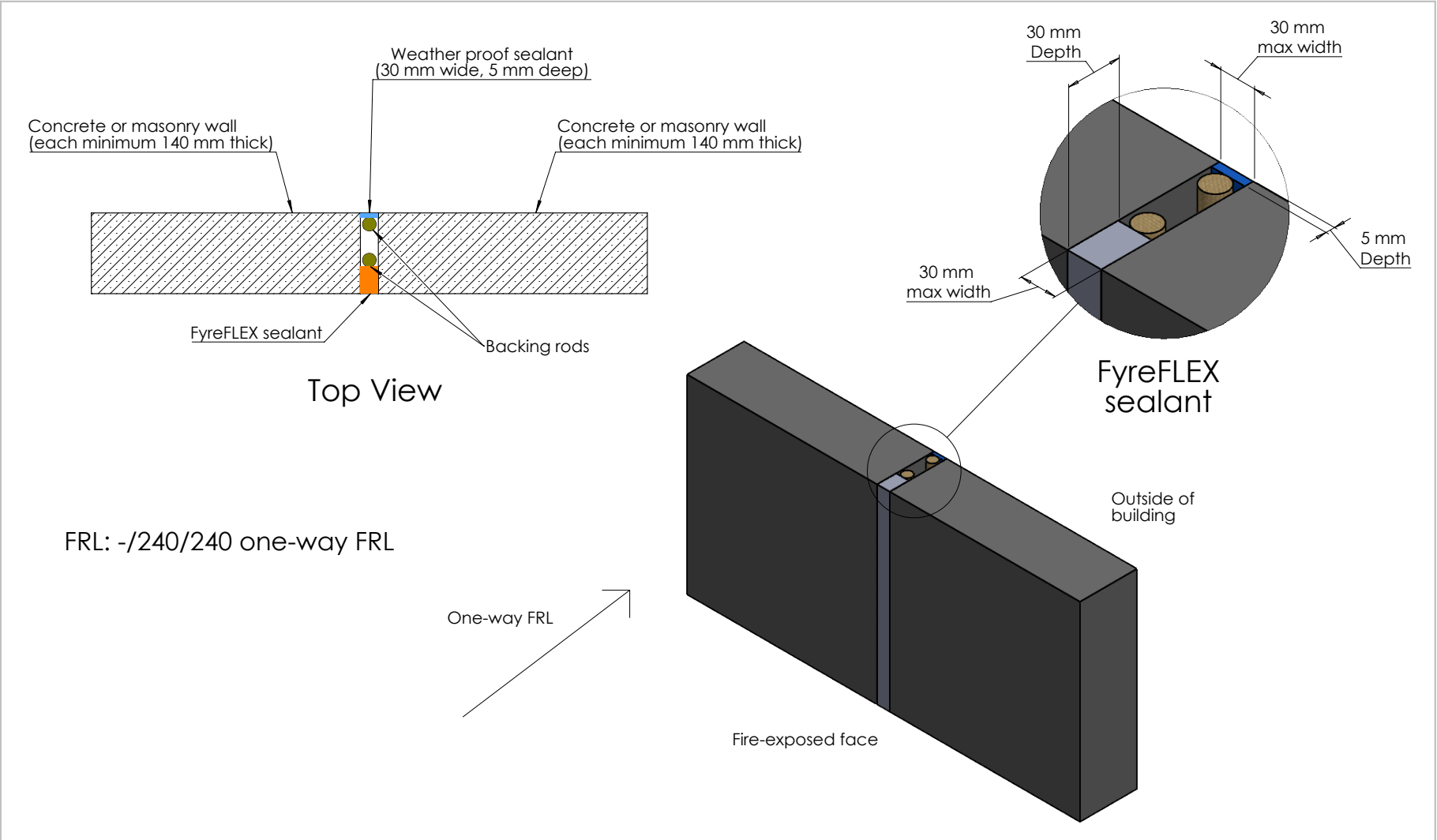

Drawing Name: Concrete/Masonry wall (with 30 mm wide control joint, for a one-way FRL)			Test Standard: AS1530.4	Codes:	Revision:	Date:	No.:	NOTICE:
Project Title: Vertical control joints drawings			Fire resistance level:	Drawn By: MI	<small>NOTE: ALL DIMENSIONS ARE IN MILLIMETRES (mm)</small>			
Drawing No. : 3	Sheet: 3 of 6	Date: 14/08/2023	Scale: NTS	Based on Report No.: FAS210386	Checked By: JH	<input type="checkbox"/> STANDARD DRAWING <input type="checkbox"/> PROJECT DRAWING		TRAFALGAR FIRE <small>Trafalgar Head Office: PO BOX 545 Chester Hill NSW 2162 T: 1800 888 714 F: 1800 201 500 E: technical@tgroup.com.au W: www.fire.com.au</small>

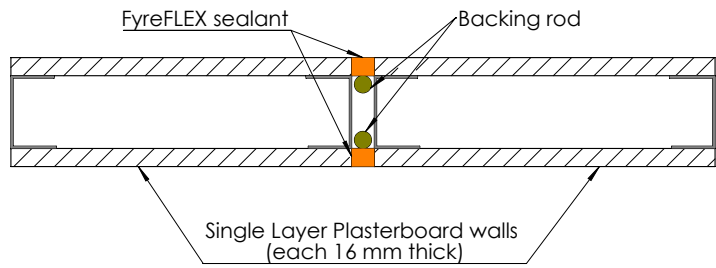

Top View

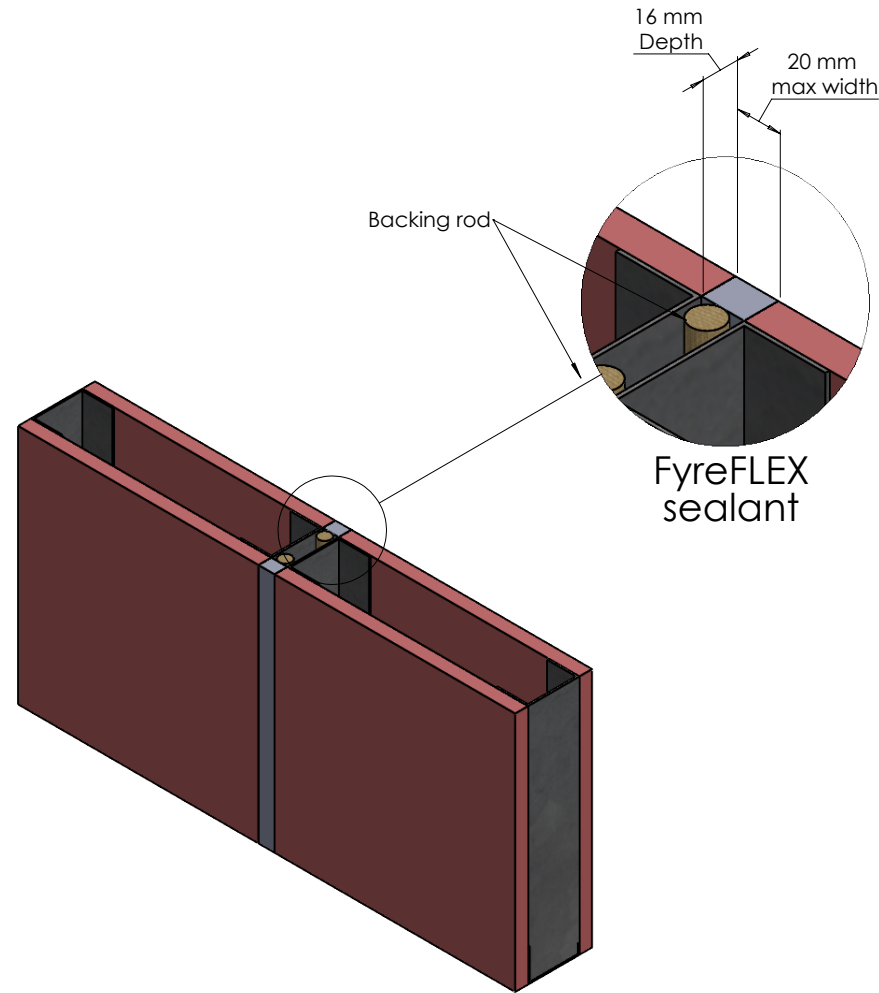

Note: this system can be applied to minimum 96 mm thick concrete or masonry walls

FRL: -/90/90

Drawing Name: Plasterboard walls (single layer) with 20 mm wide control joints		Test Standard: AS1530.4	Codes:	Revision:	Date:	No.:	NOTICE:
Project Title: Vertical control joints drawings		Fire resistance level:	Drawn By: MI	<small>NOTE: ALL DIMENSIONS ARE IN MILLIMETRES (mm)</small>			
Drawing No. : 4	Sheet: 4 of 6	Date: 14/08/2023	Scale: NTS	Based on Report No.: FAS210386	Checked By: JH	<input type="checkbox"/> STANDARD DRAWING <input type="checkbox"/> PROJECT DRAWING	

TRAFALGAR FIRE

Trafalgar Head Office:
PO BOX 545
Chester Hill NSW 2162
T: 1800 888 714
F: 1800 201 500
E: technical@tgroup.com.au
W: www.fire.com.au

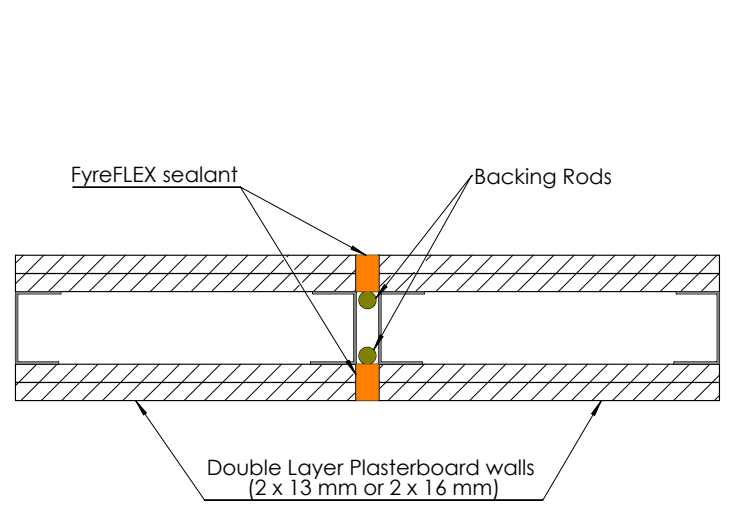

Top View

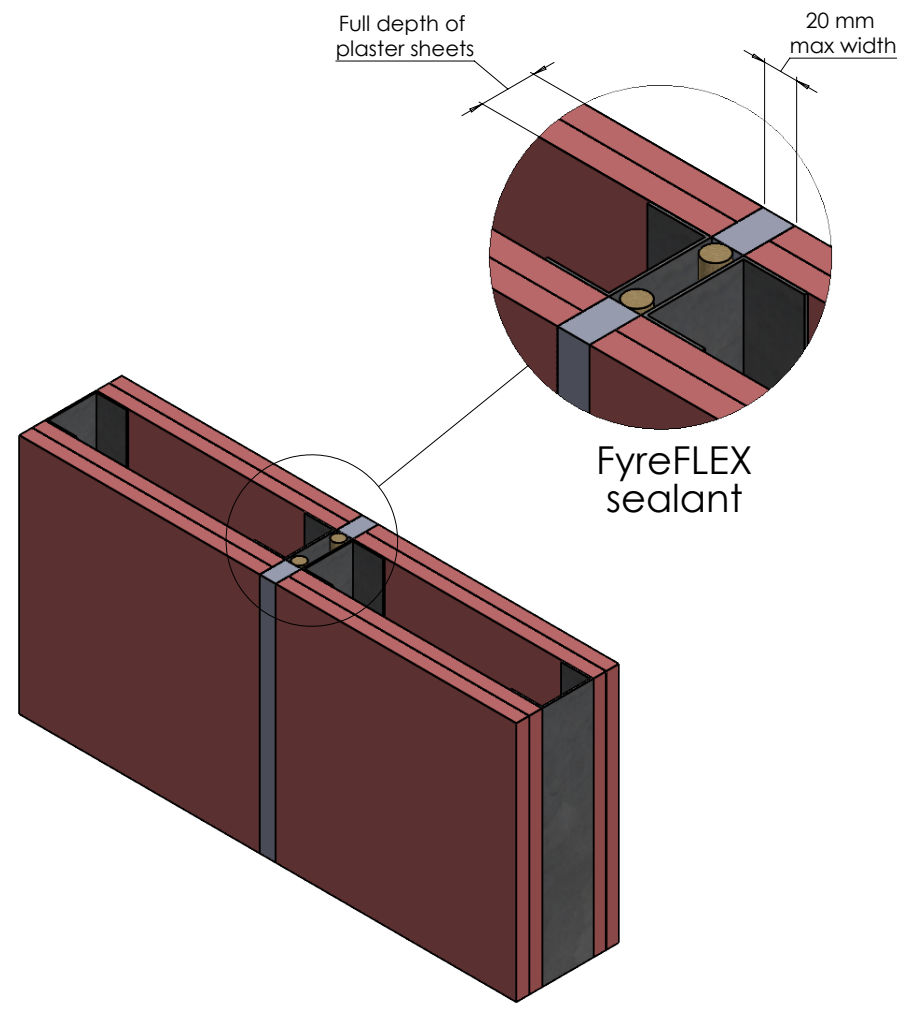

Note: this system can be applied to minimum 116 mm thick concrete or masonry walls

FRL: -/120/120

Drawing Name: Plasterboard walls (double layer) with 20 mm wide control joints		Test Standard: AS1530.4	Codes:	Revision:	Date:	No.:	NOTICE:
Project Title: Vertical control joints drawings		Fire resistance level:	Drawn By: MI	<small>NOTE: ALL DIMENSIONS ARE IN MILLIMETRES (mm)</small>			
Drawing No. : 5	Sheet: 5 of 6	Date: 14/08/2023	Scale: NTS	Based on Report No.: FAS210386	Checked By: JH	<input type="checkbox"/> STANDARD DRAWING <input type="checkbox"/> PROJECT DRAWING	

TRAFALGAR FIRE

Trafalgar Head Office:
PO BOX 545
Chester Hill NSW 2162
T: 1800 888 714
F: 1800 201 500
E: technical@tgroup.com.au
W: www.fire.com.au

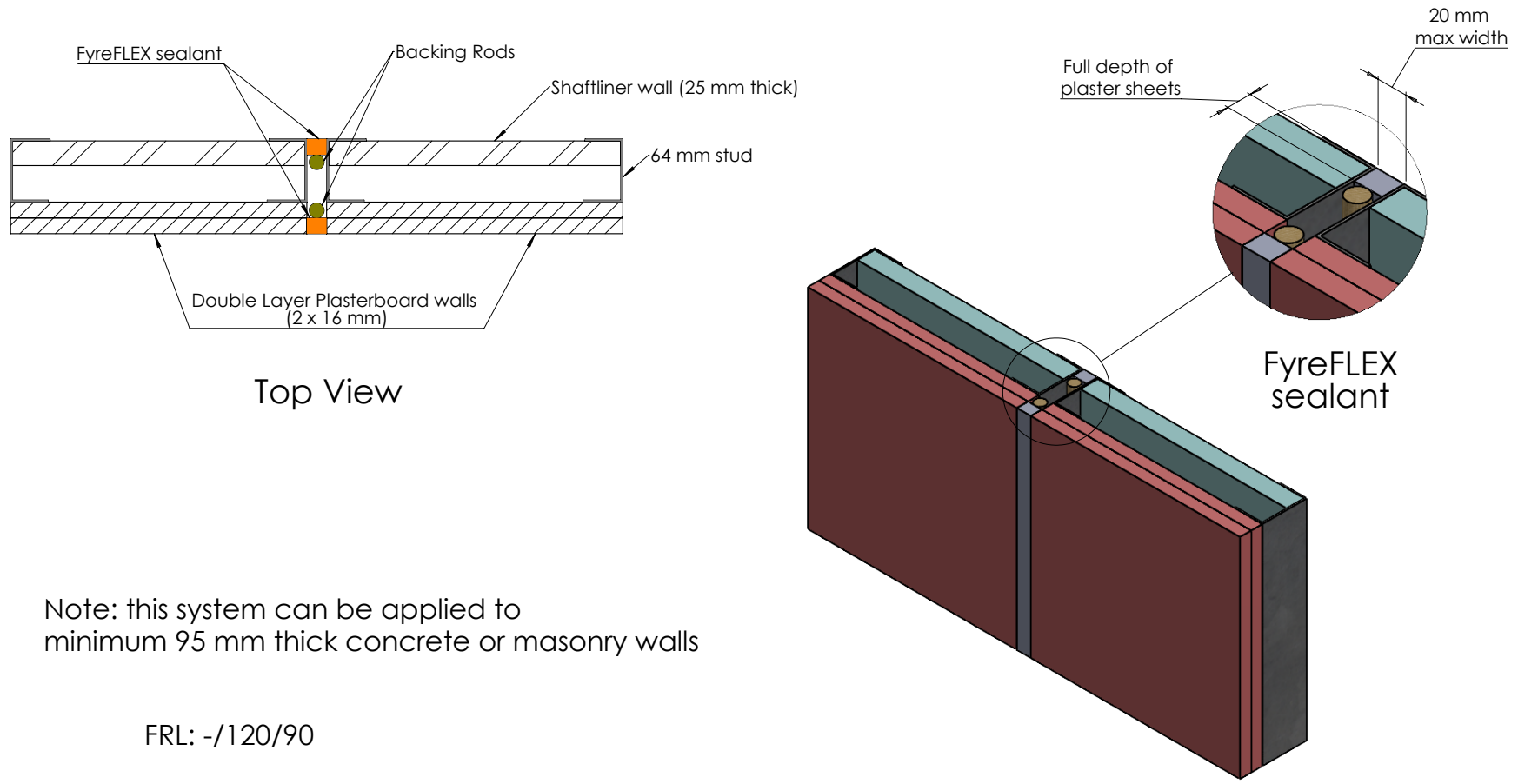

Note: this system can be applied to minimum 95 mm thick concrete or masonry walls

FRL: -/120/90

Drawing Name: Shaftliner wall with 20 mm wide control joints			Test Standard: AS1530.4	Codes:	Revision:	Date:	No.:	NOTICE:
Project Title: Vertical control joints drawings			Fire resistance level:	Drawn By: MI	<small>NOTE: ALL DIMENSIONS ARE IN MILLIMETRES (mm)</small>			
Drawing No. : 6	Sheet: 6 of 6	Date: 14/08/2023	Scale: NTS	Based on Report No.: FAS210386	Checked By: JH	<input type="checkbox"/> STANDARD DRAWING <input type="checkbox"/> PROJECT DRAWING		TRAFALGAR FIRE PO BOX 545 Chester Hill NSW 2162 T: 1800 888 714 F: 1800 201 500 E: technical@tgroup.com.au W: www.fire.com.au