

FyreDUCT Access Panel

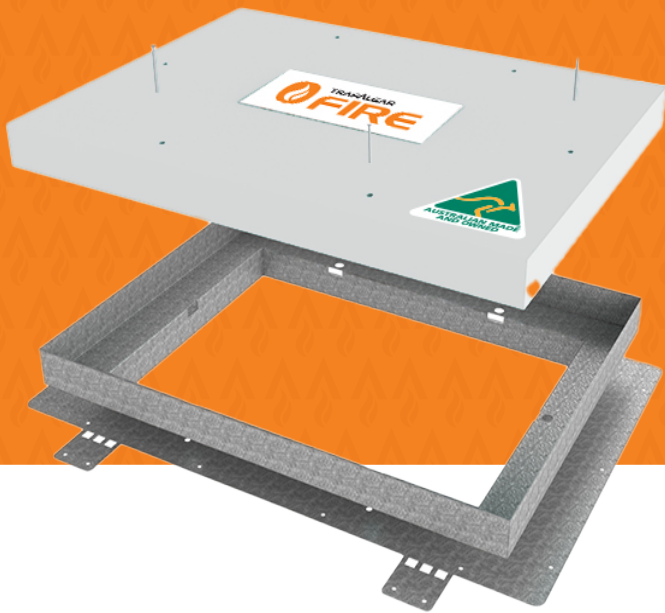

FyreDUCT Access Panels are a patented system designed for use on ducts protected by the innovative FyreWrap® and FyreSPRAYMONOKOTE® systems. These panels form part of a fully certified system to AS1530.4 to provide fire ratings on ducts and allow access easily and quickly. The patented design allows for easy installation and use, with various stock and custom sizes available the product is highly versatile.

KEY FEATURES



- Provides fast clean and easy access to fire protected ducts
- Sized to fit over existing duct access panels
- FRL up to 180/180/180
- Welded steel frame with flexible fastening tabs
- Screw fixing with machine screws for robust access
- Available in custom sizes

APPLICATIONS



- Provides access to duct work for:
- Inspection
 - Service
 - Repair
 - Replacement of internal equipment:
 - » Filters
 - » Volume Control Devices
 - » Dampers
 - » Fans

TRADES



FyreWrap® is a registered Trademark of Unifrax

TABLE OF CONTENTS



Section		Page
	Product Overview	1
	Specifications	3
	Fire Resistance Level - FyreWRAP	4
Installation	FyreDUCT Access Panels - Profile Detail	5
	FyreWRAP	6
	Fire Resistance Level - FyreSPRAY Monokote	7
	Installation: FyreSPRAY Monokote	8
	System Range	9
	FAQ	10
Technical Drawings	Access Panel Details	11
	Fan Enclosure - Front View	12
	Fan Enclosure - Side View	13
	Out of Line Damper- FyreWRAP	14
	Out of Line Damper- FyreSPRAY Monokote	15

FyreDUCT Access Panel

- Patented design with features that ensure complete flexibility and ease of installation.
- Are simply installed by fitting directly over the existing 'non-rated duct access panel' and fixed to the duct using rivets through a series of pre-drilled holes.
- Provide additional flexibility on site as they can be either pre-installed or easily retro-fitted.
- Include patented, bendable fastening tabs for slimline ducts to allow access without the need for a full box encasement.

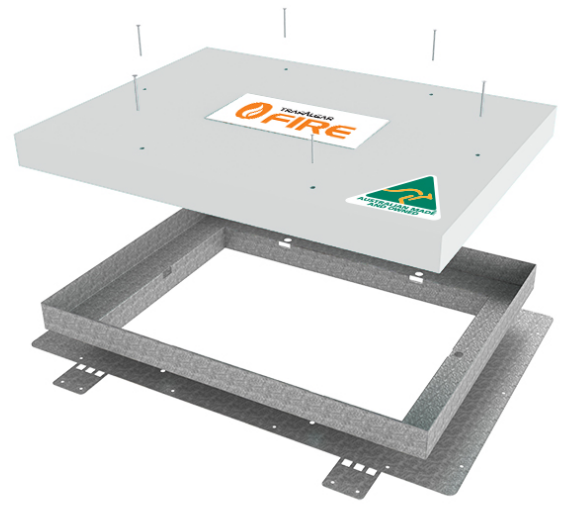

SPECIFICATIONS

	Fire Rating (System Specific)	FyreWRAP Up to 180/180/180
	Door Panel	Paint grade white hardboard incorporating FyreBOARD Maxilite® high performance fire rated board.
	Frame	Welded galvanised steel featuring patented and bendable fastening tabs.
	Fixing	Screw fixed using reusable machine screw fixings which are an integral part of the design.
	Sizes	708mm x 558mm 558mm x 433mm 433mm x 301mm 304mm x 214mm Custom up to 708mm x 558mm

FyreWrap® FRL

Fire Rating – How is fire performance measured?

An FRL (fire resistance level) is a handy way of summarising the performance of a building element. It consists of 3 numbers, all given in minutes. Ductwork uses a different FRL than other applications, shown below:

FRL 180/180/180

(example)



Structural Adequacy

The duct will maintain its size and shape allowing operation.



Integrity

The ability of an element to prevent the passage of flames and hot gases.

ie: no gases or flame passing in or out of the duct.

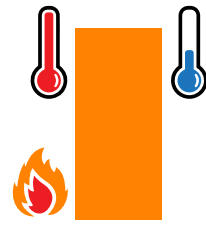

Insulation

The ability of an element to resist heat transfer from the exposed face to the unexposed face.

ie: the temperature inside or outside the duct (dependency on test type) staying below the limit.

Structural Adequacy

FyreWrap® will allow structural adequacy up to 3 hours (external fire) or 3 hours (internal fire). Unprotected supports are possible with FyreWrap® due to its lightweight nature.

Integrity

The FyreWrap® system will achieve the integrity performance of 3 hours (external fire) or 3 hours (internal fire)

Insulation (Temperature Rise)

FyreWrap® can achieve up to 3 hours insulation performance for internal and external fires with options for one or more layers depending on the FRL requirement.



Note: FyreDUCT Access Panels are tested for internal and external fire applications.

INSTALLATION

FyreDUCT ACCESS PANELS

PROFILE DETAIL

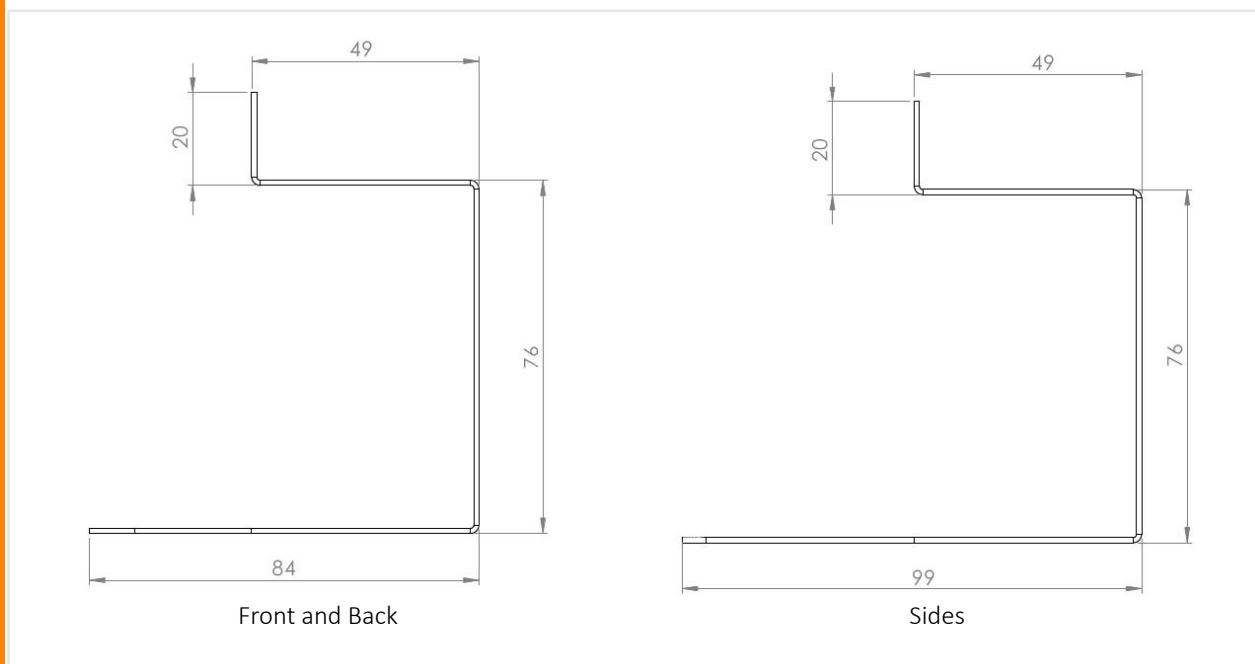

PREPARE

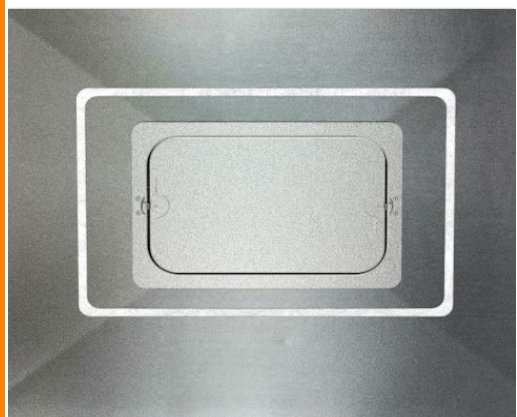

Apply FyreFLEX Sealant around the perimeter of the duct access panel to form a 'gasket' where the FyreDUCT access panel will sit.

FIX



Using the preformed holes in the FyreDUCT frame, drill and fix (using steel rivets or self-tapping screws only) the frame to the ductwork.

- * Fixings are required at maximum 150mm spacing.
- * If required for low profile ductwork, the top and bottom fold-over tabs can be folded over and fixed through the top/bottom side of the ducting.

FYREWRAF INSTALLATION

FyreDUCT ACCESS PANELS

FyreWrap® FIRST LAYER



Install FyreWrap® Elite 1.5 according to FyreWrap® installation instructions, ensuring that the material fits snugly into the provided recess in the FWAP frame on all sides. See the [FyreWRAP® Ductwork Technical Manual](#) for more details.

FyreWrap® SECOND LAYER



Install a second layer of FyreWrap® Elite 1.5, 100mm wide on all sides of the FyreDUCT Access Panel, fixing as per the standard FyreWrap® Elite 1.5 installation requirements (steel strapping or welded pins at 200mm centres).

TAPE EDGES



Tape the edges of both layers of FyreWrap® Elite 1.5 together.

FINISH



Finish the installation with a fillet of FyreFLEX Sealant to the perimeter of the FyreWrap® Access Panel, ensuring that none of the metal frame remains exposed.

FyreSPRAY MONOKOTE® FRL

Fire Rating – How is fire performance measured?

An FRL (fire resistance level) is a handy way of summarising the performance of a building element. It consists of 3 numbers, all given in minutes. Ductwork uses a different FRL than other applications, shown below:

FRL 120/120/120

(example)



Structural Adequacy

The duct will maintain its size and shape allowing operation.



Integrity

The ability of an element to prevent the passage of flames and hot gases.

ie: no gases or flame passing in or out of the duct.

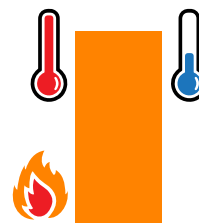

Insulation

The ability of an element to resist heat transfer from the exposed face to the unexposed face.

ie: the temperature inside or outside the duct (dependency on test type) staying below the limit.

Integrity

The FyreSPRAY MONOKOTE® system will achieve the integrity performance of 2 hours (external fire) or 2 hours (internal fire) ith FDAP.

Insulation (Temperature Rise)

FyreSPRAY MONOKOTE® can achieve up to 2 hours insulation performance for internal and external fires ith FDAP.



Note: FyreDUCT Access Panels are tested for internal and external fire applications.

MONOKOTE INSTALLATION

FyreDUCT ACCESS PANELS



Butt the mesh to the frame of the FDAP and protect the door of the FDAP with duct tape.



Spray as normal until the frame of the FDAP has been covered in spray for a width of 100mm.



FyreDUCT ACCESS PANEL

- Provides fast clean and easy access to fire protected ducts
- Sized to fit over existing duct access panels
- FRL up to 180/180/180
- Welded steel frame with flexible fastening tabs
- Screw fixing with machine screws which are an integral part of the product design
- Available in custom sizes

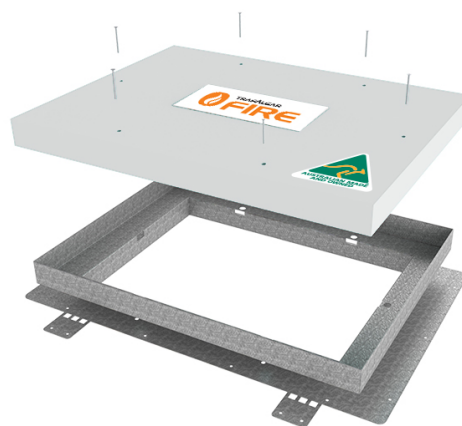

Item Number	Size	To Suit	FyreWrap® System	Qty	Pallet Qty
FD-AP-2L-AP0	708mm x 558mm	AP0	2 Layer	1	10 Panels
FD-AP-2L-AP1	558mm x 433mm	AP1	2 Layer	1	10 Panels
FD-AP-2L-AP2	433mm x 301mm	AP2	2 Layer	1	30 Panels
FD-AP-2L-AP3	304mm x 214mm	AP3	2 Layer	1	40 Panels
FD-AP-2L-CUSTOM	Custom Up to 708mm x 558mm	Custom	2 Layer	1	-

FyreDUCT ACCESS PANEL SYSTEM

Item Number	Size	Thickness	Qty	Pallet Qty
FyreFLEX 300W FyreFLEX 300G	FyreFLEX Sealant Cartridge 300ml White or Grey	-	1	1920
FyreFLEX 600W FyreFLEX 600G	FyreFLEX Sealant Sausage 600ml White or Grey	-	1	1040
FyreWrap® Elite 610	610mm wide x 7620mm long	38mm	1 roll	12 rolls
FyreWrap® Elite 1220	1220mm wide x 7620mm long	38mm	1 roll	6 rolls
Monokote 13296 MK6HY	700mmx500x120mm	-	1	55 Bags
Monokote 61951 MKZ146T	700mmx500x120mm	-	1	55 Bags
Monokote 6580 Z106HY	700mmx500x120mm	-	1	55 Bags
Monokote Accelerator	700mmx500x120mm	-	1	35 Bags

FAQ?

Q What sizes do the panels come in?

A There are a number of stock sizes to suit typical applications (AP0, AP1, etc...), however custom sizes are also available.

Q Do I need any other products?

A Simply FyreFLEX® Sealant for use in installation with FyreWRAP.

Q Do I need to remove the existing duct access panel?

A No, the FyreDUCT Access Panel fits directly over the existing panel.

Q How hard is it to open the panel?

A The panel is secured to the framing using steel machine screws for quick and easy access.

SOCIAL MEDIA



FyreDUCT Access Panel Details

Click here to go back to Contents

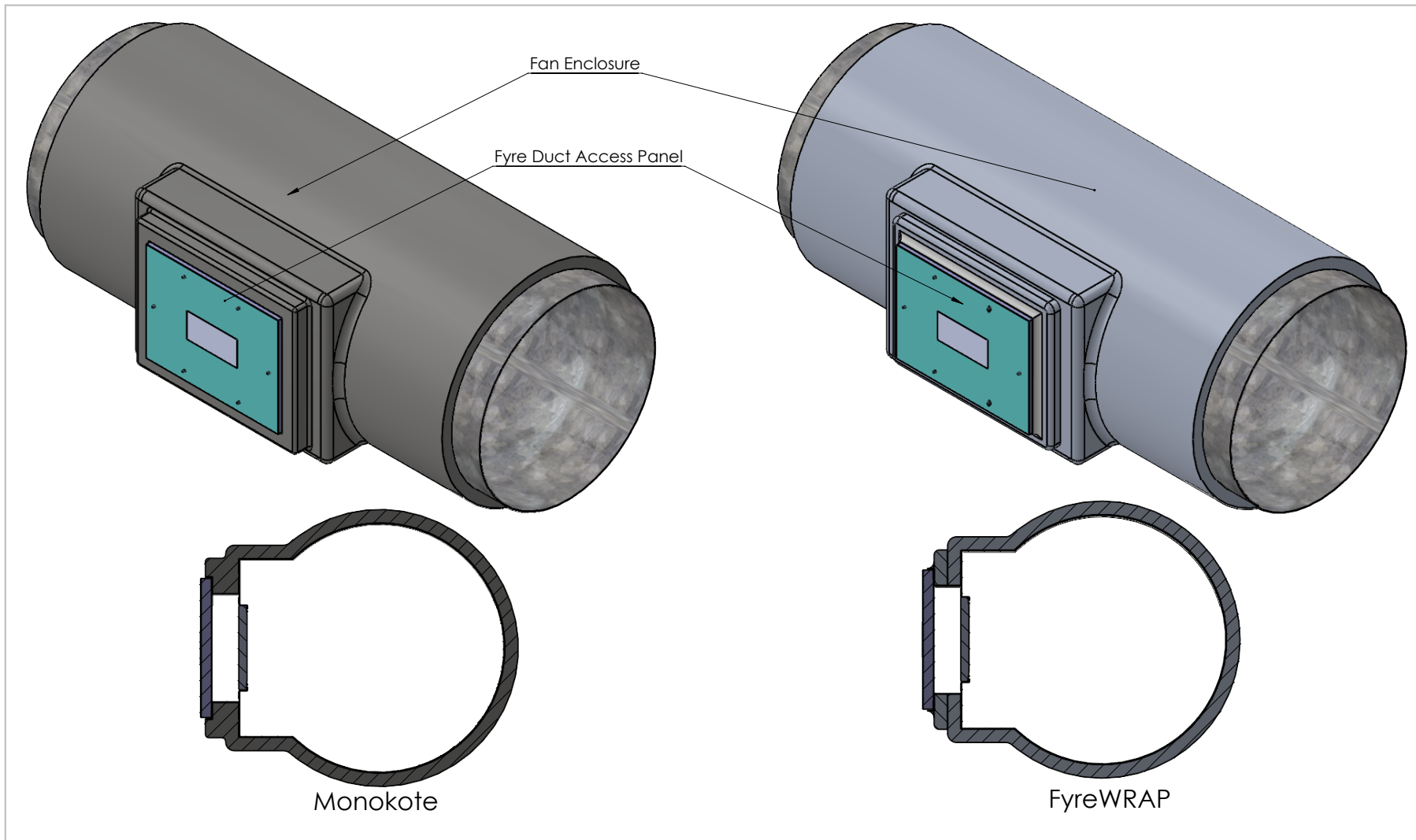



Drawing Name: FDAP in Fan Enclosure				Test Standard: AS1530.4	Codes:	Revision:	Date:	No.:	NOTICE:
Project Title: Fan Enclosure with FyreWRAP or Monokote				Fire resistance level:	Drawn By: DP	<small>NOTE: ALL DIMENSIONS ARE IN MILLIMETRES (mm)</small>			
Drawing No. : 1	Sheet: 1 of 3	Date: 6/6/2024	Scale: NTS	Based on Report No.:	Checked By: JH	<input type="checkbox"/> STANDARD DRAWING			
						<input type="checkbox"/> PROJECT DRAWING			

FWAP Fan Enclosure - Front View

Click here to go back to Contents

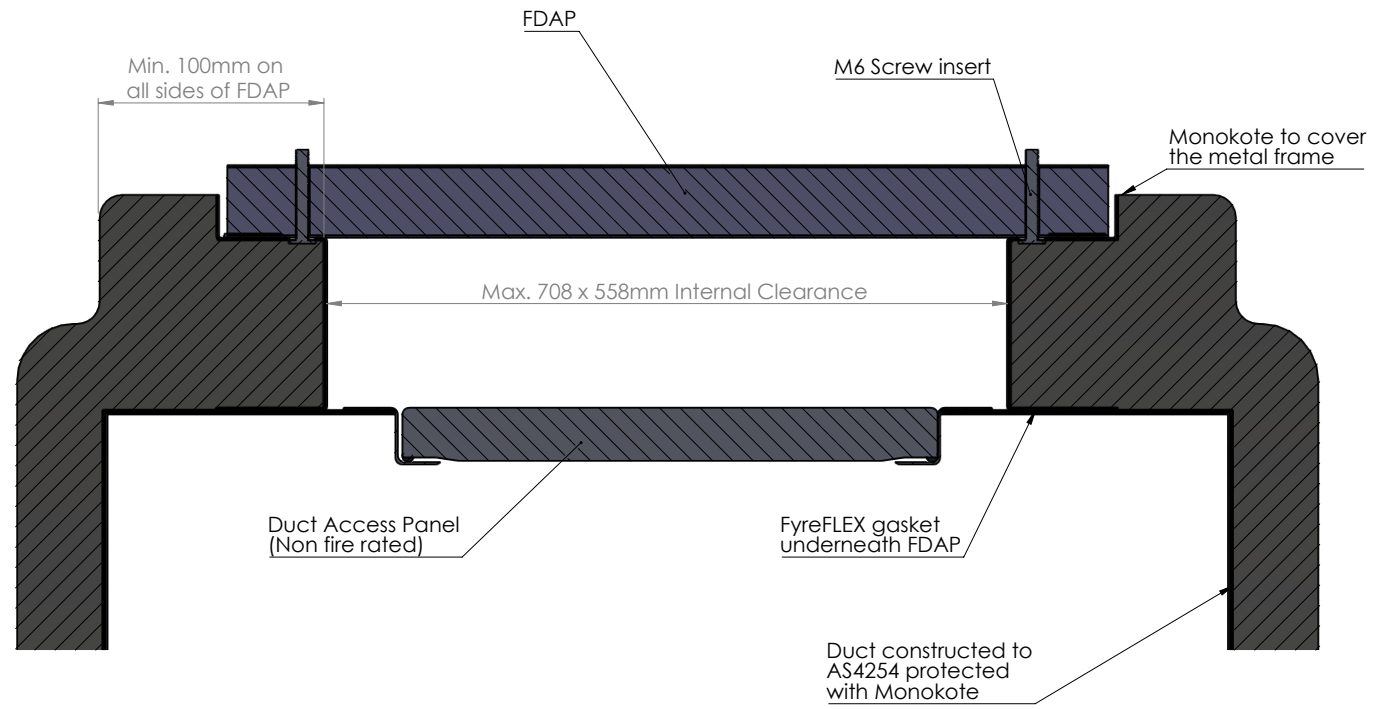
TECHNICAL DRAWINGS - FWAP FAN ENCLOSURE



Drawing Name: FDAP Monokote				Test Standard: AS1530.4	Codes:	Revision:	Date:	No.:	NOTICE:
Project Title: Fan Enclosure with FyreWRAP or Monokote				Fire resistance level:	Drawn By: DP	<small>NOTE: ALL DIMENSIONS ARE IN MILLIMETRES (mm)</small>			
Drawing No. : 2	Sheet: 2 of 3	Date: 6/6/2024	Scale: NTS	Based on Report No.:	Checked By: JH	<input type="checkbox"/> STANDARD DRAWING	 <p>TRAFALGAR FIRE PO BOX 545 Chester Hill NSW 2162 T: 1800 888 714 F: 1800 201 500 E: technical@group.com.au W: www.tfire.com.au</p>		
						<input type="checkbox"/> PROJECT DRAWING			

FWAP Fan Enclosure - Side View

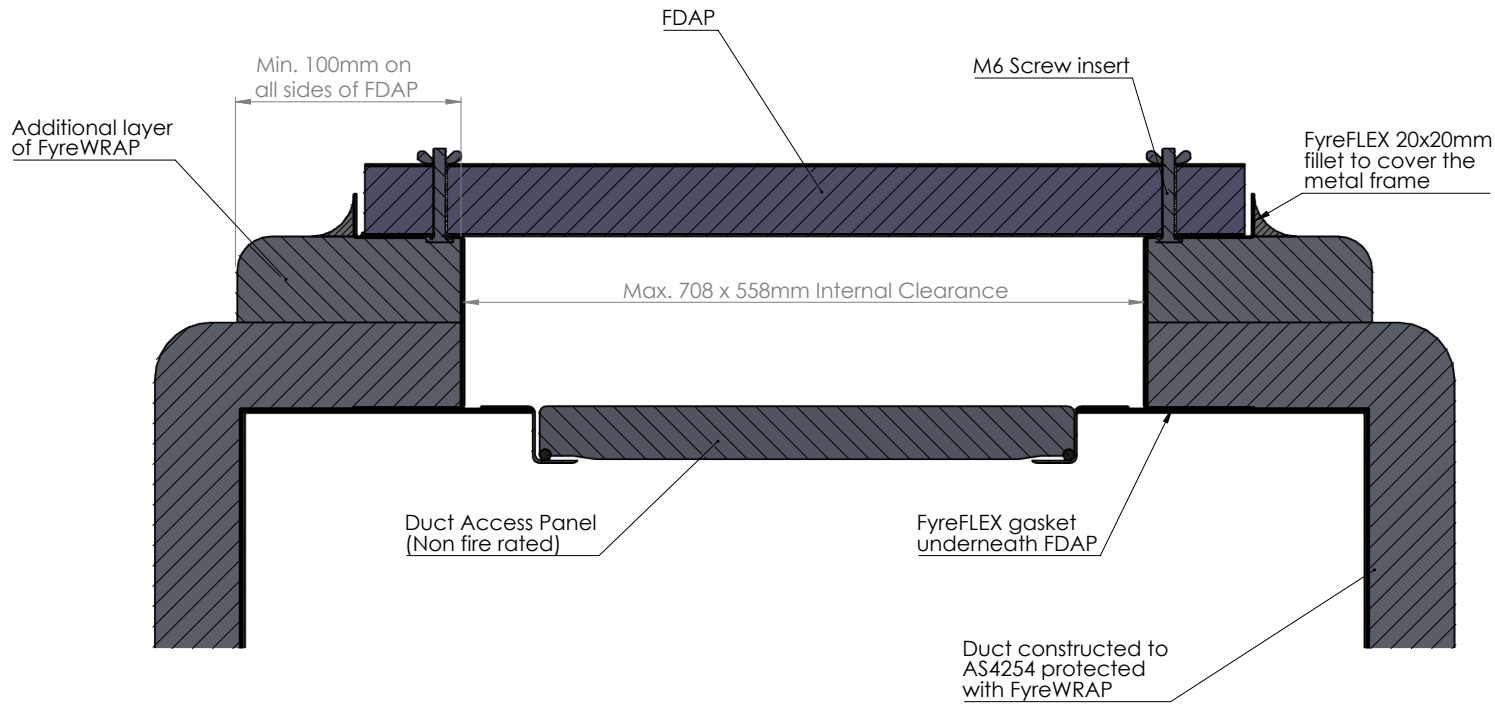

Drawing Name: FDAP FyreWRAP				Test Standard: AS1530.4	Codes:	Revision:	Date:	No.:	NOTICE:
Project Title: Fan Enclosure with FyreWRAP or Monokote				Fire resistance level:	Drawn By: DP	<small>NOTE: ALL DIMENSIONS ARE IN MILLIMETRES (mm)</small>			
Drawing No. : 3	Sheet: 3 of 3	Date: 6/6/2024	Scale: NTS	Based on Report No.:	Checked By: JH	<input type="checkbox"/> STANDARD DRAWING			
						<input type="checkbox"/> PROJECT DRAWING			

Out of Line Damper

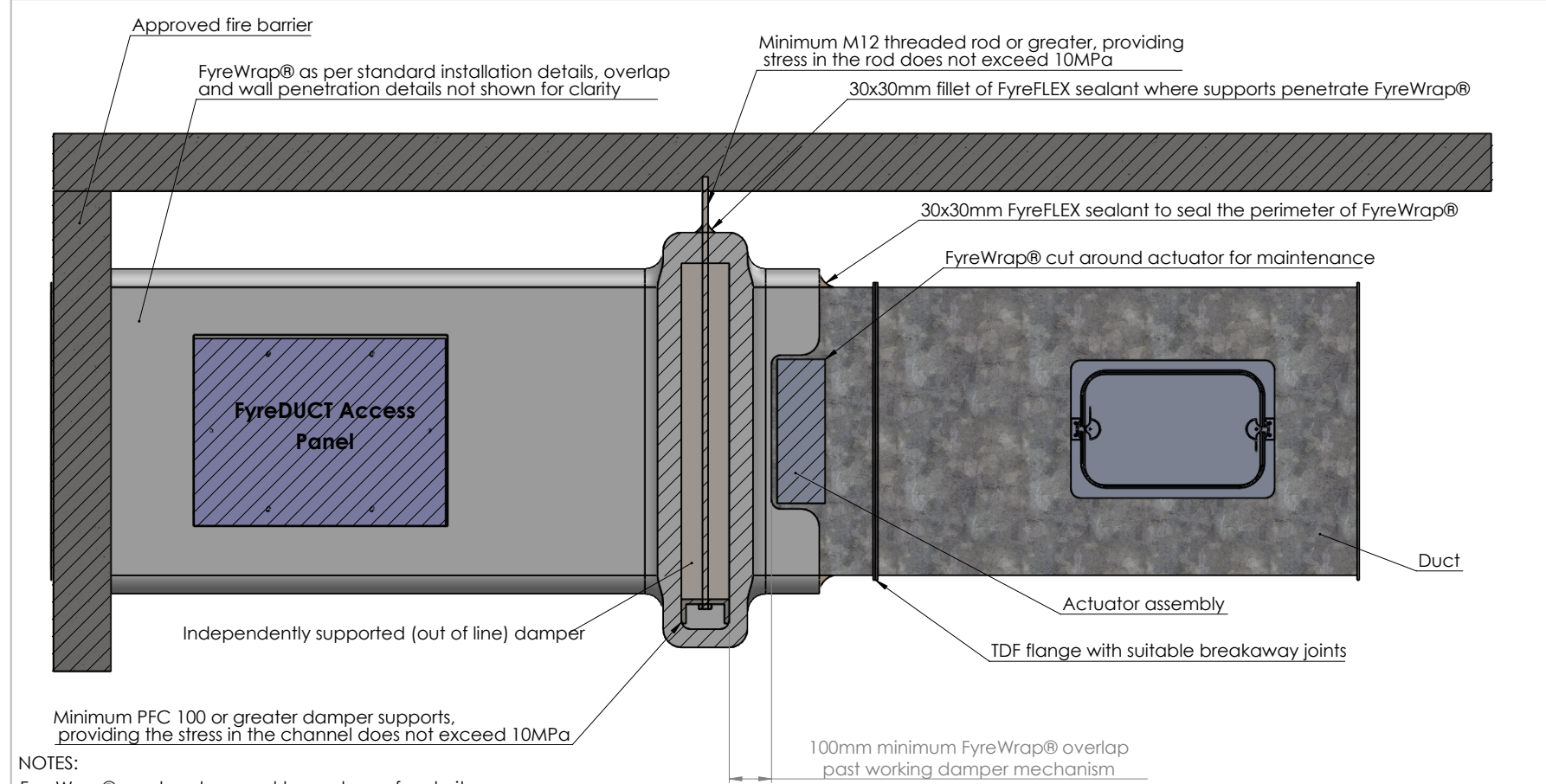

NOTES:
 -FyreWrap® overlaps have not been shown for clarity
 -Dampers to be installed to manufacturers instructions
 -Damper fixings not shown for clarity
 -Adequate fixings of FyreWrap® to be in conjunction with Trafalgar Fire's recommendation of maximum nominal duct size
 -Threaded rod diameters and steel sections **MUST NOT** exceed the allowable stress limit of 10MPa in accordance with Trafalgar Fire's **BRANZ FAR 2567 report**
 -indicates required location of break-away joints

Drawing Name: Out of line damper install				Test Standard: AS1530.4	Codes:	Revision:	Date:	No.:	NOTICE:
Project Title: Out of line damper drawings				Fire resistance level:	Drawn By: JH	NOTE: ALL DIMENSIONS ARE IN MILLIMETRES (mm)			
Drawing No. :	Sheet:	Date: 12/10/2020	Scale:	Based on Report No.:	Checked By: CT				



Out of Line Damper - Monokote

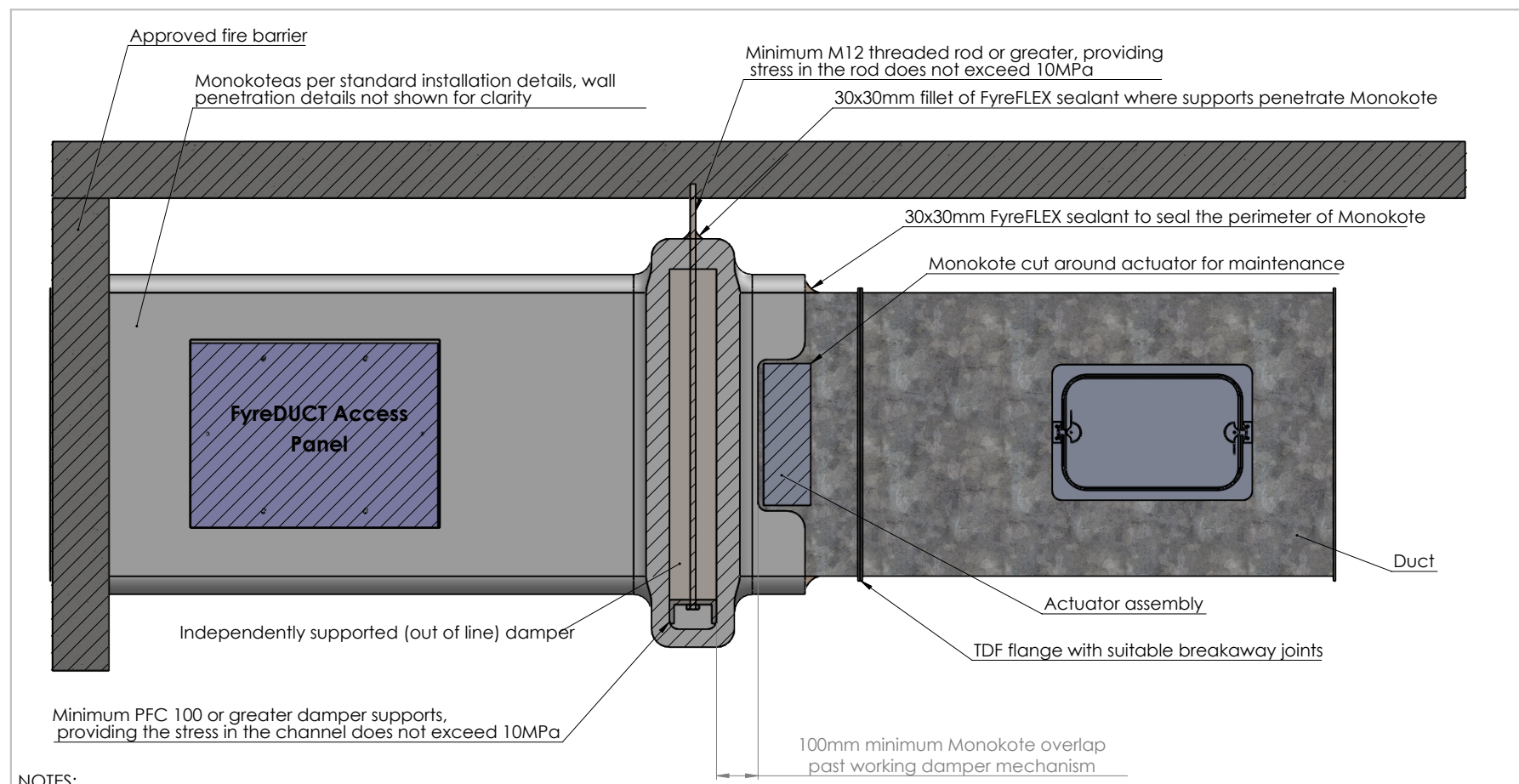

NOTES:

- Dampers to be installed to manufacturers instructions
- Damper fixings not shown for clarity

Drawing Name: Out of line damper install				Test Standard: AS1530.4	Codes:	Revision:	Date:	No.:	NOTICE:
Project Title: Out of line damper drawings				Fire resistance level:	Drawn By: JH	NOTE: ALL DIMENSIONS ARE IN MILLIMETRES (mm)			
Drawing No. :	Sheet:	Date: 12/10/2020	Scale:	Based on Report No.:	Checked By: CT				

