

FyreCOLLAR Mixed Service

Trafalgar Fire is proud to present our newly developed Mixed Service Collar approvals for HVAC&R penetrations with our FyreCOLLAR Mixed Services. Treat multiple sets of pair coil plus their cables, insulated pipes and drain lines all through one penetration, making HVAC&R penetrations fast, clean and easy.



SYSTEM COMPONENTS

FyreCOLLAR CONDUIT

FyreFLEX

TWRAP

APPLICATIONS

- Up to three sets of pair coil
- Include cables and pipes in one penetration
- Insulated copper pipes
- Retrofit solution
- Suitable for walls and floors
- No need to strip off pipe insulation
- Easy identification for visible compliance
- Cost effective

TRADES



TABLE OF CONTENTS



Section	Page
Benefits	3
Compliance	4
FRL Tables	
Retrofit Applications- Mixed Service Collar Approvals	5
Installation	
Holes Sizes	6
FyreCOLLAR All Walls	7
FyreCOLLAR Wall Types	8
System Range	9
FAQ	10
Technical Drawings	
Overview Wrap Free - Multi-Service Collar Drawing Package	11
Overview TWRAP™ - Multi-Service Collar Drawing Package	12
TWRAP™ Details	13
FyreBOARD Maxilite® - FyreCOLLAR Retro-fit	14

BENEFITS

Trafalgar Fire listens to the market and try to provide new and cost-effective solutions, backed with full fire testing and Trafalgar's technical support.

We are proud to launch our new range of mixed services collar approvals. HVAC&R services, such as bundles of pair coils and small insulated copper pipes, are use throughout our buildings. This provides a special challenge in fire conditions as the insulation materials melt quickly and create gaps for fire and smoke to pass through.

The combination of our high-performance intumescent material and FyreFLEX® sealant, ensure an air-tight, fire safe penetration complete with important smoke sealing attributes.



UNIQUE CHALLENGES OF HVAC&R SERVICE PENETRATIONS

HVAC&R pipes require thermal insulation to maintain the thermal efficiencies required to run air-conditioning and refrigeration services. However, these thermal insulation materials will quickly burn away in the high temperatures of an AS1530.4 fire test, which makes passive fire penetrations of HVAC&R services more complicated when compared to bare metal pipe penetrations for example.

In addition to this, most pair coil installations are run in conjunction with power and data cables, plus PVC drains, adding further complexity to the passive fire design.

FyreCOLLAR Mixed Services are lined with an intumescent material that expands with the heat of a fire to close off the gaps around services inside of a fire collar, filling up the spaces left by the burning/melted thermal lagging to tightly seal around the copper pipes. The high-grade intumescent material is strong enough to crush off pair coil insulation and form a tight seal around the cables, so all of these services can be bundled together to make passive fire protection of HVAC&R services fast and easy.

The use of high performance intumescent sealants, like our FyrePEX™ HP Intumescent Sealant is time consuming and expensive to do, and provides problems for certifiers to inspect and ensure the correct system has been used. The signature orange of the FyreCOLLAR Mixed Services collar means easy identification and visible compliance for the certifier.



COMPLIANCE



COMPLIANCE WITH THE NATIONAL CONSTRUCTION CODE (NCC)

Formerly known as BCA

The National Construction Code (formerly the BCA) has strict requirements for the protection of openings for service penetrations given in clause C3.15.

The key to compliance is that you are installing a 'system' and not a product, so despite what other manufactures may claim, there is no such thing as a fire rated collar – only a fire rated collar system!

What that means is mixed service collars must be fire tested to AS1530.4 with each different configuration of services, each different fire barrier and each different size that are intended to be installed on site. On site, the collars must be installed identically to how they are tested/approved for compliance to be met.

Trafalgar Fire have completed numerous fire tests for mixed service applications in various walls and floors, and have had a formal assessment report in accordance with AS4072.1-2005 and AS1530.4-2014 (report FC11190) which can be downloaded from [the Test Reports page in our Knowledge Centre](#), which covers:

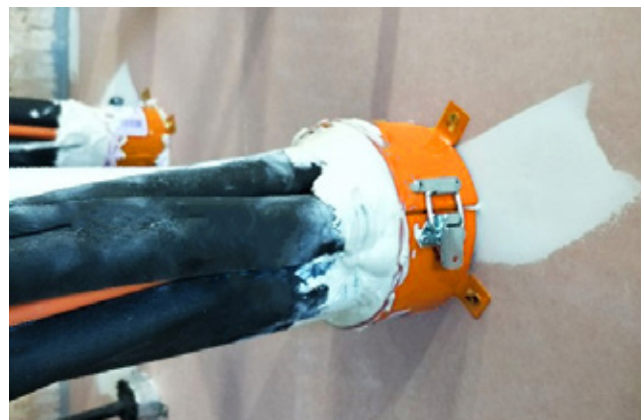

Fire barriers	Approved system details
<ul style="list-style-type: none"> • Single and double layer plasterboard • Hebel®/WALSC AAC panel walls • Concrete and masonry walls • Speedpanel® 78mm walls • FyreBOARD Maxilite® (for oversized openings) 	<ul style="list-style-type: none"> • FRL's of -/60/60, -/90/90 and -/120/120 using TWRAP™ as required • Up to 3x sets of pair coil with their power and data cables • Collar sizes 50mm, 65mm, 80mm and 100mm • FR and PE thermal pipe insulation

Note: FyreCOLLAR are only suitable for use on the services they are tested for.

For larger bundles of cables and other mixed services please refer to the FireBOX™ range.

RETROFIT APPLICATIONS

MIXED SERVICE COLLAR APPROVALS



APPROVED SERVICE BUNDLES

Service	Specification	Size(s)
Refrigeration pipes	Copper pipes with FR insulation	Single copper pipes up to 20mm with FR insulation
Pair coil	Twin copper tubes with FR or PE thermal insulation	Up to 20mm diameter (3/4" & 3/8" for examples) copper pipe with: <ul style="list-style-type: none"> FR Pipe insulation up to 25mm thickness PE Pipe insulation up to 19mm
Optional inclusion of:		
Power cable	TPS or orange circular cables	<ul style="list-style-type: none"> TPS cables up to 2.5mm² 3C+E cables up to 2.5mm²
Data cable	CAT6	6mm OD

For collar sizing, installation and other additional information, refer to the [FyreCOLLAR Premium Retrofit Collar Technical Manual](#).

Fire barrier (min thickness)	Installation	Wrap Free FRL*	FRL with 300mm TWRAP™
Single layer 13mm plasterboard wall	Refrigeration pipes and up to 3x HVAC Service bundles, each consisting of: <ul style="list-style-type: none"> 1xPair coil 1xPower cable 1xData cable Collar/core hole size dependent on quantity and size of services, refer to FyreCOLLAR Premium Retrofit Collar Technical Manual for installation requirements.	-/60/60	Wrap Free
Single layer 16mm plasterboard wall		-/90/60	-/90/90
Double layer 13mm plasterboard wall		N/A	-/120/120
Hebel® or WALSC AAC panel 75mm wall		-/90/60	-/90/90
Speedpanel® 78mm wall		N/A	-/120/120
Concrete/masonry walls		N/A	-/120/120
Concrete floors		-/120/120**	-/120/120
FyreBOARD Maxilite® board 60mm		N/A	-/90/60
FyreBOARD Maxilite® board 90mm (locally thickened)		-/90/60	-/120/120

*PE insulations will require 300mm TWRAP™ applied to both sides of the wall.

** Applies to max of x2 pair coil only.

INSTALLATION ANNULAR GAP REQUIREMENTS

HOLE SIZES

WHAT IS AN ANNULAR GAP?

The annular gap is the clearance between the pipe and the hole as illustrated in this image by the orange bar. Annular gaps should be limited to a maximum of 7.5mm, as shown below.

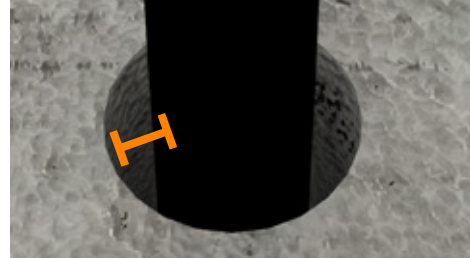

TABLE 1: FyreCOLLAR RETROFIT

Product Code	Collar Size	Max Hole Size
FyreCOLLAR-PHRC-50	50mm	65mm
FyreCOLLAR-PHRC-65	65mm	80mm
FyreCOLLAR-PHRC-80	80mm	95mm
FyreCOLLAR-PHRC-100	100mm	115mm



Note: This table references a maximum annular gap of 7.5mm between the service and the hole in the separating barrier. Annular gaps are to be sealed with FyreFLEX® Sealant.

INSTALLATION FyreCOLLAR IN WALLS

ALL WALLS

CUT HOLE



Ensure that the opening in the wall/floor is within the approved size range (no more than 7.5mm annular gap as per the table on page 6). Ensure the surface is clean for the installation of FyreFLEX® Sealant.

SEAL



Fill the annular gap between the service and wall with FyreFLEX® Sealant for a depth of 10mm, on both sides of a wall or top and bottom of a floor.

FyreFLEX® Sealant between the hole and services can be applied flush with the wall without a fillet. Check the table on page 6 for the appropriate hole size for each collar.

FIT



Fit the FyreCOLLAR Premium Retrofit Collar, undo the latch to open the collar, secure it around the service/s, and re-secure the latch.

FIX



Use appropriate fixings as per page 8 to secure the collar to the wall/floor using all of the available the fixing tabs.

Click To Watch



INSTALLATION FyreCOLLAR IN WALLS

ALL WALLS



Speedpanel walls require a 60mm thick piece of FyreBOARD Maxilite® to be screw fixed onto one side of the penetration, before attaching the collar. See table below for screw fixings. Seal all gaps and perimeter with FyreFLEX® Sealant.



Where annular gaps exist between the services and the collar, back-fill these FyreFLEX® Sealant to the full depth of the collar.

Collars are installed to the bottom side of a floor only, or to both sides of a wall.

TABLE 3: FyreCOLLAR FIXINGS

Type	Fixing	
Walls	Single Layer Plasterboard	
	Double Layer Plasterboard	
	FyreBOARD Maxilite®	
	AAC Wall/ Hebel 75mm	6g x 25mm screws
	Speedpanel® 78mm	Side 1 into bare Speedpanel® - HEX head metal screws 12-14 x 20mm Side 2 FyreBOARD Maxilite® into Speedpanel® - 10g x 100mm plasterboard screws in each corner Side 2 Collar into FyreBOARD Maxilite® - 6 x 25mm screws
Concrete/Masonry	M6 x 50mm masonry anchors	
Floors	Concrete/Masonry	M6 x 50mm masonry anchors

SYSTEM RANGE



Item Number	Collar Size	To Suit Nominal Service Size	Inner Diameter	Outer Diameter	Height	Min Order Qty
FyreCOLLAR-PHRC-50	50mm	50mm	58mm	72mm	62mm	1
FyreCOLLAR-PHRC-65	65mm	65mm	72mm	90mm	62mm	1
FyreCOLLAR-PHRC-80	80mm	80mm	85mm	102mm	62mm	1
FyreCOLLAR-PHRC-100	100mm	100mm	115mm	133mm	62mm	1

FAQ

Q Do I need a collar on both sides of the wall?

A Yes, for walls. Floors however, only require a collar on the underside of the penetration.

Q Do you have a test report for these approvals?

A Yes, download our reports directly from the Trafalgar Fire website at tfire.com.au/Test_Reports

Q Do I need sealant around the services?

A Yes, but no need for expensive intumescent sealants - seal the collars with FyreFLEX® sealant around the services in the wall and backfill the collar to close any gaps between services and provide a smoke seal.

Q Can I use FyreCOLLAR on bondek floor slabs?

A Yes using FyreBOARD Maxilite®. Contact technical@tgroup.com.au for more information.

Q Can I use these collars on bunches of electrical cables?

A No, these cable penetrations are best to be sealed with a system that has been tested for the application, like FyreFLEX® sealant and TWRAP™ or FireBOX™ systems.

Q Can I use FyreCOLLAR on PVC pipes and conduits?

A Yes, as long as each service is in a separate penetration. Refer to [FyreCOLLAR Premium Retrofit Technical Manual](#) for a full list of approvals.

SOCIAL MEDIA



Linked in

YouTube

Trafalgar Fire reserves the right to change specifications without notice. Please check with your supplier at the time of order. The information contained in this Technical Manual was correct at the time of publication. E&OE.

Click here to go back to Contents

TECHNICAL DRAWINGS - OVERVIEW WRAP FREE

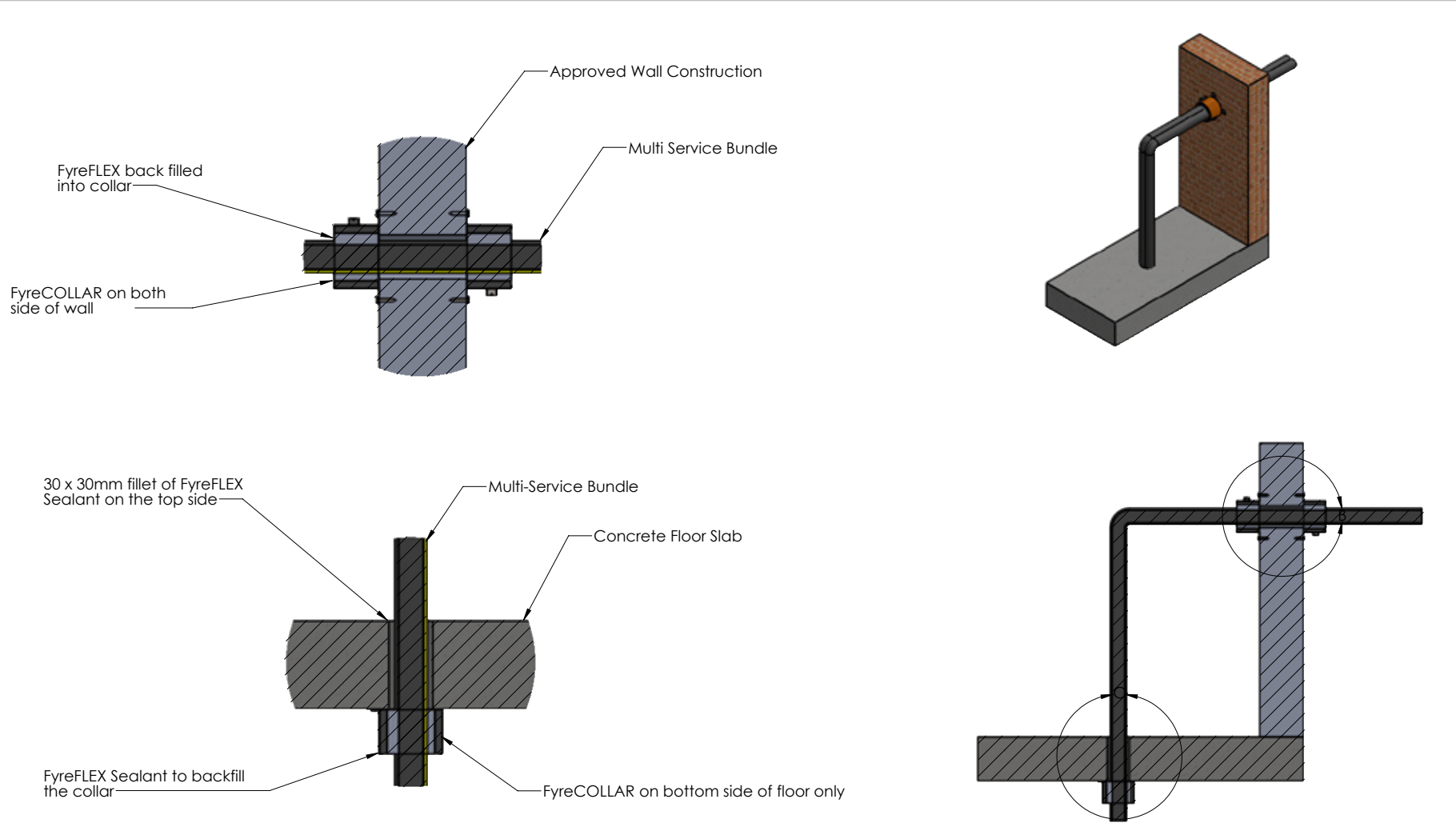

Note: To determine if TWrap is required, refer to the FRL tables of the technical manual.

Drawing Name: Overview - Wrap Free				Test Standard: AS1530.4	Codes:	Revision:	Date:	No.:	NOTICE:
Project Title: Multi-Service Collar Drawing Package				Fire resistance level:	Drawn By: SM	<small>NOTE: ALL DIMENSIONS ARE IN MILLIMETRES (mm).</small>			
Drawing No. : 2	Sheet: 2 of 3	Date: 13/07/2021	Scale: NTS	Based on Report No.:	Checked By: JH	<input type="checkbox"/> STANDARD DRAWING	 <p>TRAFALGAR Head Office: PO BOX 545 Chester Hill NSW 2162 T: 1800 888 714 F: 1800 201 500 E: technical@tgroup.com.au W: www.tfire.com.au</p>		
						<input type="checkbox"/> PROJECT DRAWING			

Click here to go back to Contents

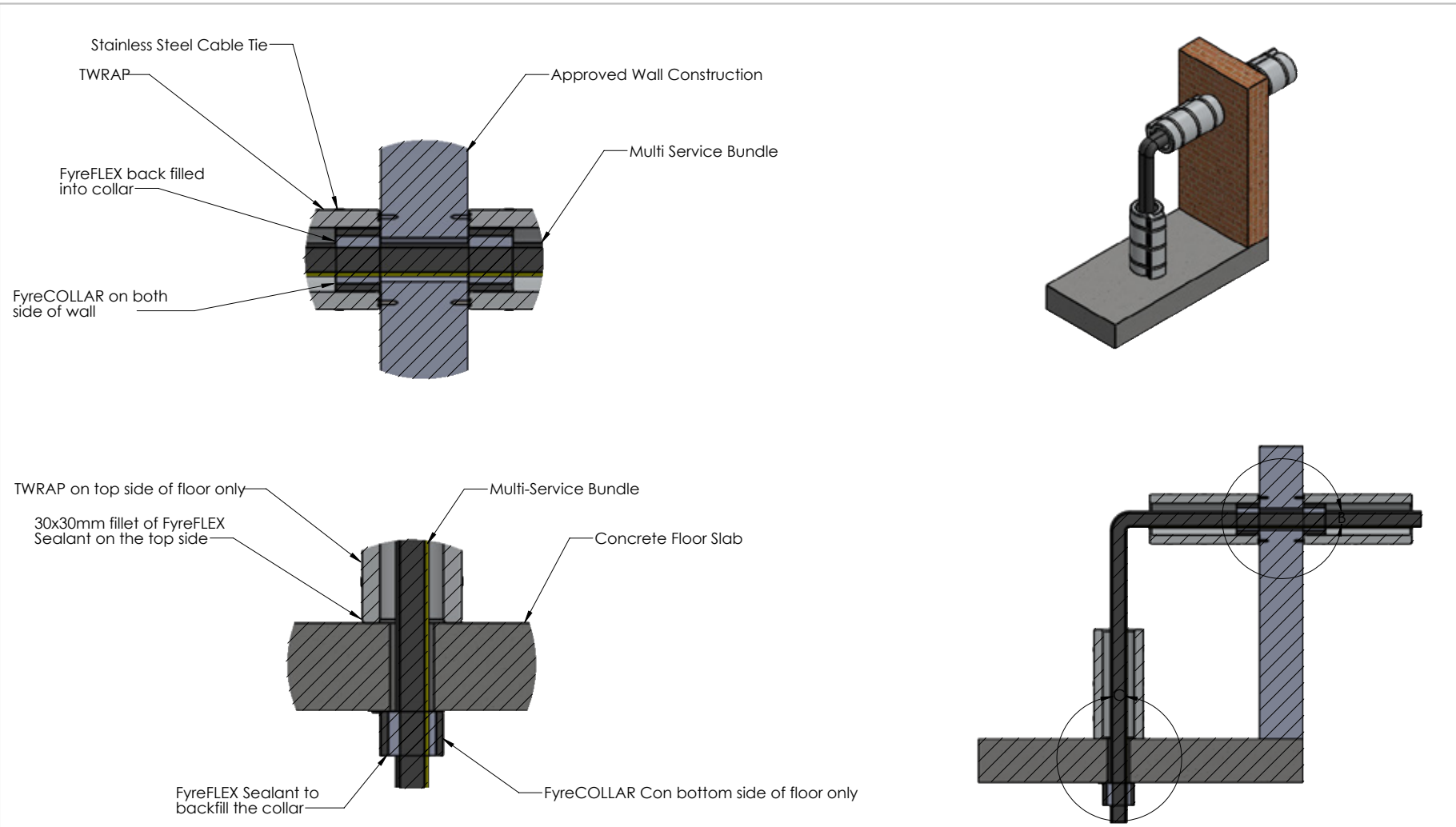

Note: To determine if TWRAP is required, refer to the FRL tables of the technical manual.

Drawing Name: Overview - TWrap				Test Standard: AS1530.4	Codes:	Revision:	Date:	No.:	NOTICE:
Project Title: Multi-Service Collar Drawing Package				Fire resistance level:	Drawn By: SM	<small>NOTE: ALL DIMENSIONS ARE IN MILLIMETRES (mm)</small>			
Drawing No. : 1	Sheet: 1 of 3	Date: 13/07/2021	Scale: NTS	Based on Report No.:	Checked By: JH	<input type="checkbox"/> STANDARD DRAWING	 TRAFALGAR FIRE Trafalgar Head Office: PO BOX 545 Chester Hill NSW 2162 T: 1800 888 714 F: 1800 201 500 E: technical@tgroup.com.au W: www.tfire.com.au		
						<input type="checkbox"/> PROJECT DRAWING			

Click here to go back to Contents

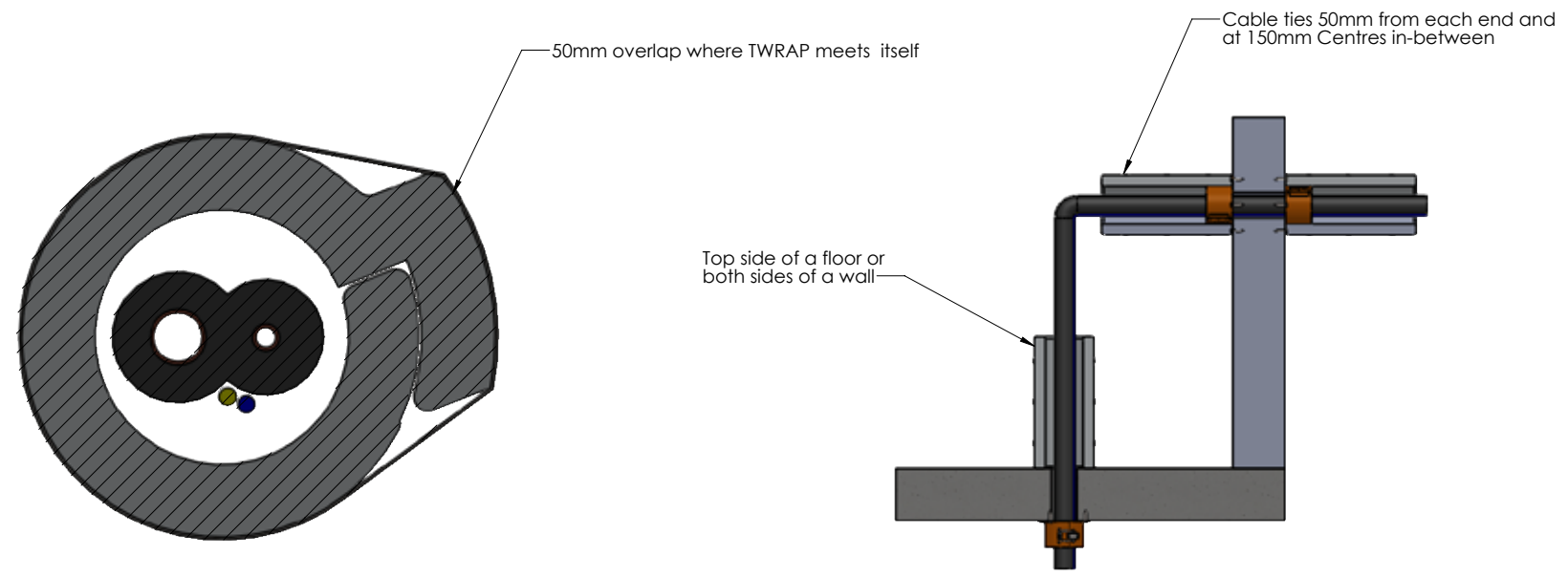

Drawing Name: TWRAP Details				Test Standard: AS1530.4	Codes:	Revision:	Date:	No.:	NOTICE:
Project Title: Multi-Service Collar Drawing Package				Fire resistance level:	Drawn By: SM	<small>NOTE: ALL DIMENSIONS ARE IN MILLIMETRES (mm).</small>			
Drawing No. : 3	Sheet: 3 of 3	Date: 13/07/2021	Scale: NTS	Based on Report No.:	Checked By: JH	<input type="checkbox"/> STANDARD DRAWING	 <p>TRAFALGAR FIRE PO BOX 545 Chester Hill NSW 2162 T: 1800 888 714 F: 1800 201 500 E: technical@group.com.au W: www.tfire.com.au</p>		
						<input type="checkbox"/> PROJECT DRAWING			

Click here to go back to Contents

FyreBOARD Maxilite - Oversized Openings

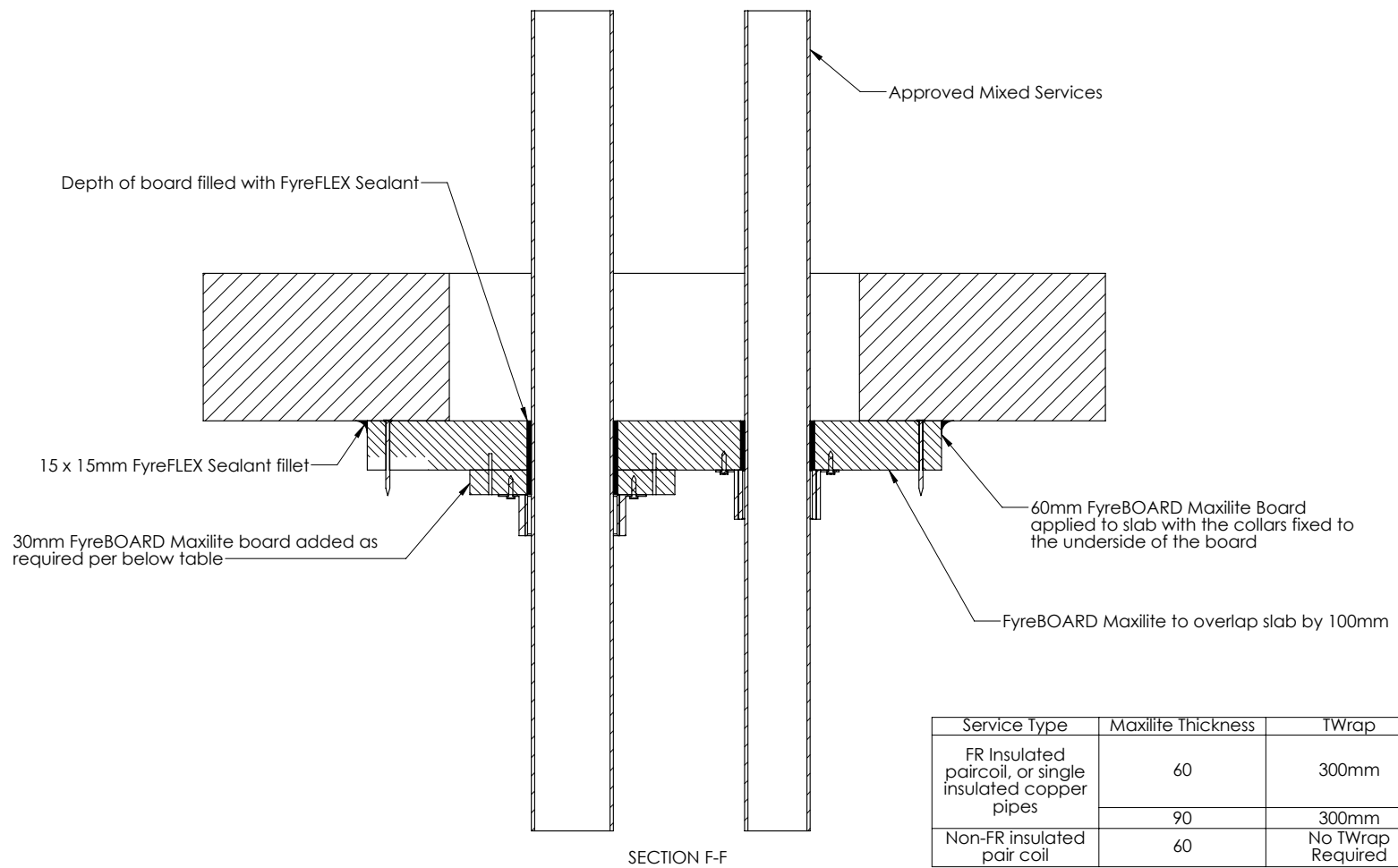

Service Type	Maxilite Thickness	TWrap	FRL
FR Insulated paircoil, or single insulated copper pipes	60	300mm	-/60/60
	90	300mm	-/120/120
Non-FR insulated pair coil	60	No TWrap Required	-/90/30

Note: This applies to wall penetrations also, however FyreCHOKe Collar's must be applied to both sides of a wall. For further assistance contact technical@tgroup.com.au

Drawing Name: FyreBOARD Maxilite			Test Standard: AS1530.4	Codes:	Revision:	Date:	No.:	NOTICE:
Project Title: FyreCOLLAR Retro-fit Collars			Fire resistance level:	Drawn By: SM	<small>NOTE: ALL DIMENSIONS ARE IN MILLIMETRES (mm).</small>			
Drawing No. : 1	Sheet: 1 of 1	Date: 13/07/2021	Scale: NTS	Based on Report No.:	Checked By: JH	<input type="checkbox"/> STANDARD DRAWING <input type="checkbox"/> PROJECT DRAWING		

TRAFALGAR FIRE

Trafalgar Head Office:
 PO BOX 545
 Chester Hill NSW 2162
 T: 1800 888 714
 F: 1800 201 500
 E: technical@tgroup.com.au
 W: www.fire.com.au