



Image: "Search and rescue forces searching through a destroyed building" - licensed under CC BY 2.0

Trafalgar Fire Article by:
John Rakic, Sean McDonald, John Henry & Chris Todd

Seismic Testing of Fire Stopping Products: Can we build to withstand an earthquake?

SEISMIC TESTING OF FIRE STOPPING PRODUCTS

By Rakic, J. , McDonald, S. , Henry, J. & Todd, C.



Image: View of collapsed cathedral in Christchurch, New Zealand Feb 2011" - by Martin Luff is licensed under CC BY 2.0

Earthquakes and their associated aftershocks have proven to challenge the way we build.

SEISMIC TESTING OF FIRE STOPPING PRODUCTS

By Rakic, J. , McDonald, S. , Henry, J. & Todd, C.

Introduction

It feels like yesterday, but most of us remember exactly where we were and what we were doing when mother nature reminded us on the impact she can have on the built environment across the ditch in Christchurch, New Zealand.



Image: "Dust clouds above Christchurch"- by Gillian Needham , NZ Ministry for Culture and Heritage.



Image Brighton, Christchurch Feb 2011"- by Martin Luff is licensed under CC BY 2.0

A major earthquake occurred in Christchurch, New Zealand, on Tuesday 22 February 2011 at 12:51 p.m. local time. The M_w 6.2 earthquake struck the Canterbury region in the South Island, centred 6.7 kilometres south-east of the centre of Christchurch, the country's second-most populous city.

The damage to the building stock is well reported and the rebuilding of Christchurch is still ongoing more than 10 years later.

Fire and smoke walls were severely damaged and essential fire and other safety measures were rendered inoperable, which allows fire, post the event to destroy in inside of some buildings.

The building designers in New Zealand, Code officials and the like, just like elsewhere in the world previous after a major earthquake, had to STOP, assess what they learnt from observations post the "quake" and start designing & rebuilding more robust buildings and fitting them out with more seismic resistant walls, risers or service shafts, ceilings and the like.

This article deals specifically with services which pass through so-called fire rated and smoke proof barriers and looks at seismic testing protocols, any acceptance criteria for fire stopping systems, and discussed some work conducted by Trafalgar Fire of our Australian made SuperSTOPPER systems which part of our ongoing research and development in seismic performance of passive fire protection or fire stopping systems.

The Start of the Seismic Product Development and System Journey

The insurance, fire and structural design fraternity and building owners had an appetite and a demand for something to hang their hats on at the design stage, but alas there was not too much, or pretty much nothing meaningful to use.

“Does Trafalgar have any seismic testing for its passive products?”

“We cannot find any meaningful test data for penetration seals.”

“Will you do some testing?”

“Yes of course, to what test method? What performance do you need?”

“What wall types are you using? Can they deal with the movement?”

“Let us do some research and look at a research and development testing program.....”

Desktop Literature Review and Google to the Rescue

There is very little published performance data for performance of penetration seals or services passing through openings and their seismic performance.

We did discover that there are so-called “shaker tables” that allow simulated movement, with a defined displacement in mm and an acceleration or frequency of cycles; but what displacement and frequency do we use and why?

I am sure Trafalgar is not the first do some work, but what we could find was ad hoc at best, conducted at in house laboratories, and the movement (or displacement) and acceleration were only relevant for a light tremor, not a major earthquake event

Thank you to our American friends who have some preliminary documentation that can be applied to seismic testing and provide some tangible data for use by structural, seismic and the designers involved in seismic proof buildings or structures.

Performance-Based Seismic Design Guidelines

The literature review unearthed the following performance based seismic designed guidelines:

- **FEMA 461**

2001, saw the start of a project sponsored by both FEMA (the USA Federal Emergency Management Agency) and the USA Department of Homeland Security. Work conducted initially by the USA Applied Technology Centre (ATC) lead to the development of some seismic design guidelines for both **NEW** and **EXISTING** buildings.

The work was also supported in part by the USA Earthquake Engineering Research Centre and the USA National Science Foundation. All this manifested itself in the publication FEMA 461 which provides different means to measures in laboratories the seismic performance of building elements.

Interim testing protocols were developed for **Quasi Static Testing** and for **Shake Table Testing** along with Functional Performance criteria and Anticipated Damage States.

As the description suggests, a Shake Table allows one to shake the proverbial out of a structure or part of a structure, simulating an earthquake and to look at the performance and damage state of what is being tested.

Just like fire testing, it makes for a fun day for Engineering folk like us at Trafalgar Fire.



Interim Testing Protocols for Determining the Seismic Performance Characteristics of Structural and Nonstructural Components

FEMA 461 / June 2007

- **ICC-ES AC156**

Again, and thanks to our friends in the USA, The International Code Council (ICC) the ICC-ES scheme develop and publish proven techniques for products that foster safe and sustainable design and construction.

ICC-ES, AC156 was first published in 2010 and was updates as recently as 2020, and is documented acceptance criteria, for seismic certification by shake-table testing on non-structural (building) components.



ES ICC EVALUATION SERVICE

www.icc-es.com | (800) 423-6587 | (562) 899-0543 A Subsidiary of the International Code Council®

**ACCEPTANCE CRITERIA FOR SEISMIC CERTIFICATION BY
SHAKE-TABLE TESTING OF NONSTRUCTURAL COMPONENTS**

AC156

Approved October 2010

Effective November 1, 2010

Previously approved December 2006, June 2004, and January 2000

- **ASTM E3037**

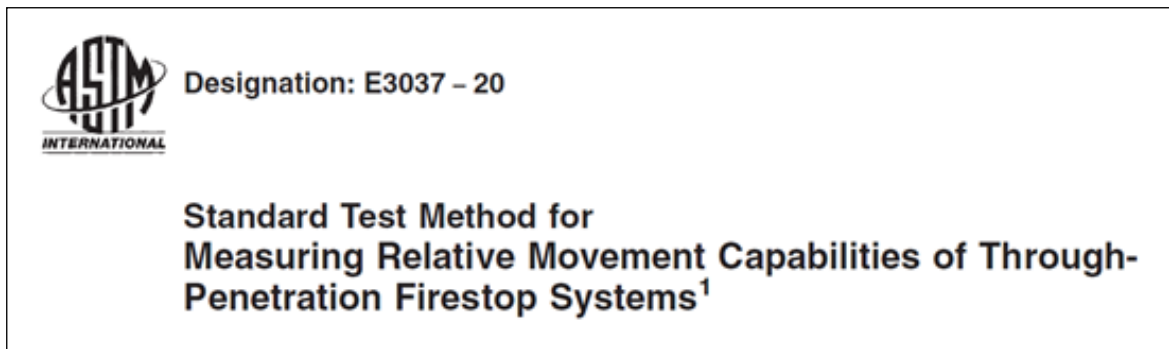

Another documented test method which uses a shake-table. As written, the movement testing required is very small and moves at snail's pace and provides little or no useful data for seismic applications.

The side-to-side movement (Y direction) on goes one way for the central axis and not back and forwards about the axis. There is no testing of up and down movement.

There is some out of plane movement (Z direction) which is one positive as we feel this is the most onerous movement orientation for fire stop materials.

Just to qualify the somewhat tongue and cheek snail's pace comment, the movement speed is 500mm/min, so for a 50mm of movement, this is 10 cycles per minute, or 0.265 Hz.

All literature reviews we have seen suggest that frequency need to be in the order of 1.3 to 2.5Hz depending on the magnitude of the earthquake we are designing for.

So in short, unless the ASTM E 3037 method is used with this frequency, we think it is of little or no use to provide any confidence in seismic design.

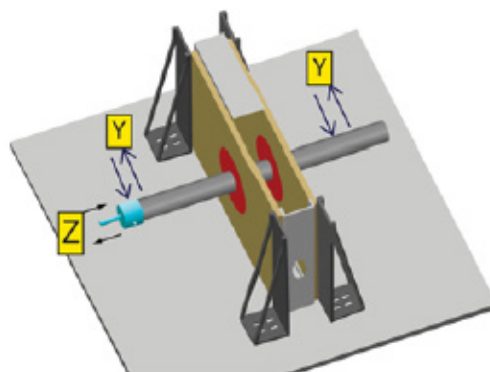

Shake-Table Testing Design Variables

We asked a lot of questions from the seismic design community, especially in New Zealand where the appetite for seismic product performance was rife.

Sadly, everybody had a different approach to seismic design and what test data they thought would be usefull if Trafalgar was to commision som independent seismic testing.

The design variables we identified were:

- Displacement** or amplitude of seismic movement measure in mm
- Movement Direction**, up and down and most important out of plane movement of the service relative to a wall for example
- Acceleration** of movement
- Frequency** of movement in cycles per minute or seconds; the latter being measured in Hz

We were about to step into a new space we knew very little about. We had to now decide what movement cycles we should subject our firestopping systems to.

From first principals, we knew that whatever fire stop system we used, it would need to be compressible or somehow allow for up and down movement, but the out of plane movement was the biggest concern, as the services will have a tendency we thought, to pull the fire stopping out of the wall.

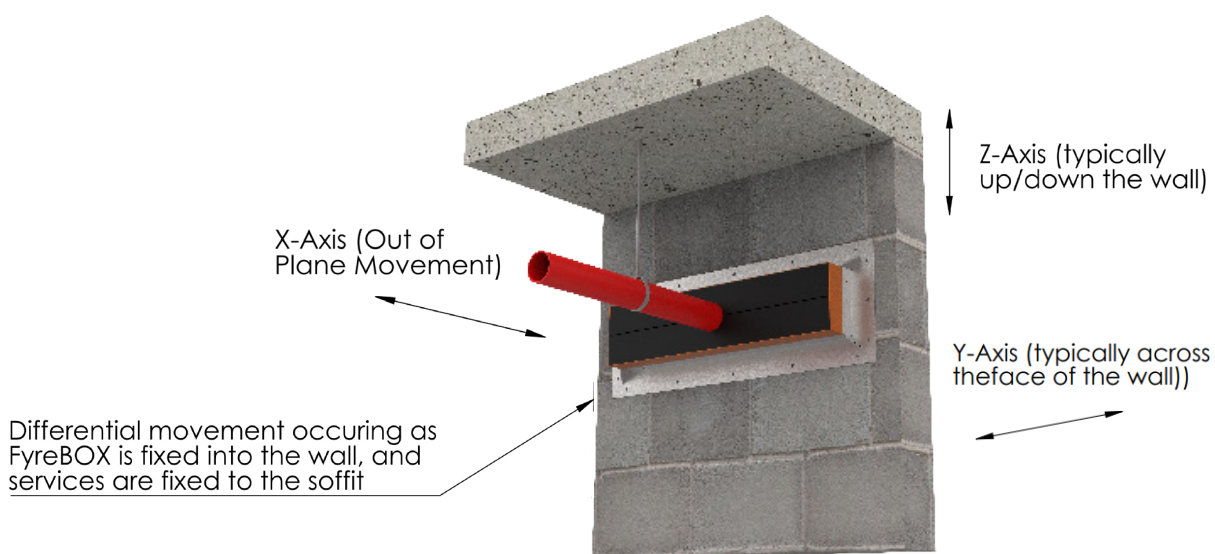

Trafalgar Seismic Testing

We chose our initial testing to be conducted in New Zealand and chose Holmes Solutions in Christchurch.

Some prominent seismic consultants in New Zealand gave us their wish list for the testing parameters and we decided to start our research and development program with our Trafalgar SuperSTOPPER systems. These are a metallic box incorporating high performance graphite intumescent material, positioned centrally inside the internal perimeter of the box along with graphite impregnated foam inserts or end plugs for the end of the box. These were developed for passive fire protection of services and Trafalgar Fire have several patented applications for what we call SuperSTOPPER. The services run through the box, and the ends are sealed around the services passing through the box with the smoke, acoustic and airtight foam inserts of end plugs.

What services do we use?

How much will the foam end plugs get damaged by movement? How much movement?

Will the foam end plugs be pulled out by the services when they move?

Will the SuperSTOPPER assembly be capable of maintaining fire resistance and limit the movement of smoke post a seismic event?

What magnitude of earthquake?

This is going to be interesting and fun, but remember fellow Trafalgar Engineers, its COVID and money is not plentiful after months of diminished sales.

Can we get some Government funding for what Trafalgar thinks is leading edge research and hopefully providing results which will benefit the Built Environment?

Oops, we cannot go to New Zealand to do the installation due to COVID restrictions. So lets hope we find a laboratory that can do the installation and run the tests without us being present.

It's time to have some fun.

Trafalgar Shake Table Testing at Holmes Solutions

SEISMIC TESTING OF FIRE STOPPING PRODUCTS

By Rakic, J. , McDonald, S. , Henry, J. & Todd, C.

Stage One – Seismic Testing of Trafalgar SuperSTOPPER

Some of our Trafalgar SuperSTOPPER 550 x 125mm boxes were sent to Holmes Solutions in New Zealand and Stage One of our Seismic journey started in 2021.

The Holmes Solutions' shake-table assembly and control equipment allowed us huge scope to experiment on the seismic performance of our Trafalgar SuperSTOPPER.

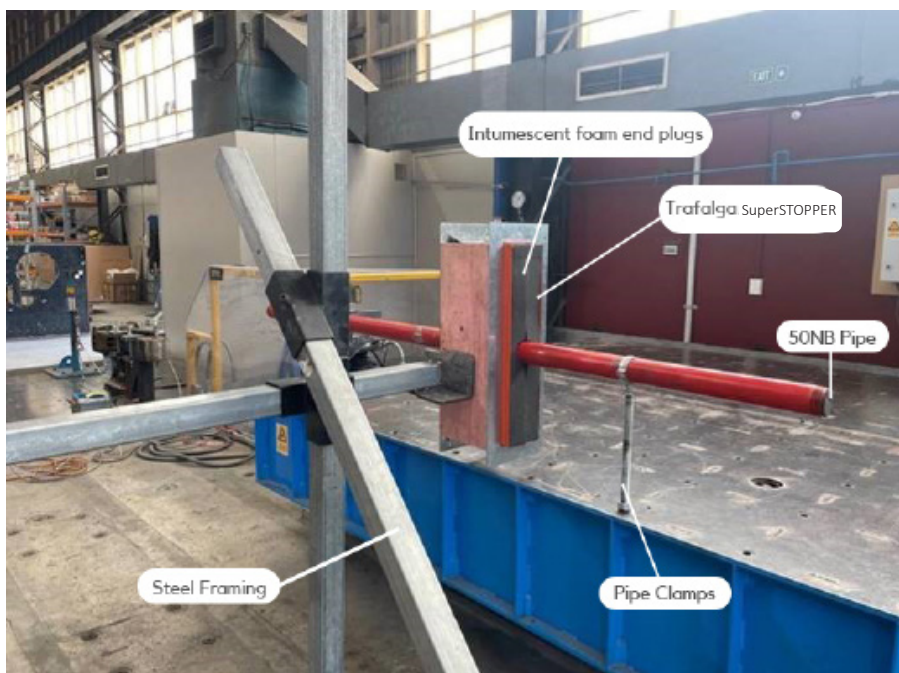

Shake-table test setup of Trafalgar SuperSTOPPER MAXI

Trafalgar Shake Table Testing at Holmes Solutions

Preliminary Seismic Testing – The Ad-hoc and Unreported Initial Trials

We had no idea if the foam ends plugs, which form an integral part of a Trafalgar SuperSTOPPER would pop out, tear or what would happen to them once the shake table did it's thing. This is we guess why we call these experiments research and developments.

We wanted to know if the Trafalgar SuperSTOPPER did fail or perform poorly, at what displacement or movement amplitude, at what speed or frequency of repeat movement cycles.

We made an executive decision to use our FyreFLEX acrylic fire sealant around the perimeter of the foam end plugs to help them stay in place. We did not put any sealant around the metal pipe service or on the joints where the foam is cut to allow fitting with an existing service in situ.

Testing was conducted uniaxially, that is in one direction at a time or in other words in the X, Y & Z axis (up and down, side to side and out of plane relative to a wall for example) individually, one at a time.

Test Installation

Trafalgar FyreBLOC was fixed to a rigid structure while the pipe was fixed to the shake-table. Replicating differential movement between the wall which the FyreBLOC is fixed to and the service withing the FyreBLOC. Pipe supports not shown

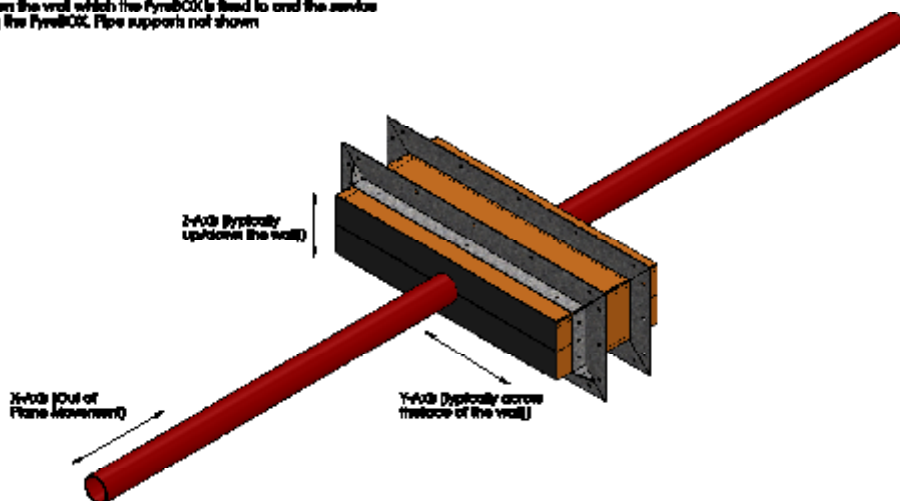

Stage One testing used a nominal 50mm steel sprinkler pipe penetrating the SuperSTOPPER.

SEISMIC TESTING OF FIRE STOPPING PRODUCTS

By Rakic, J. , McDonald, S. , Henry, J. & Todd, C.

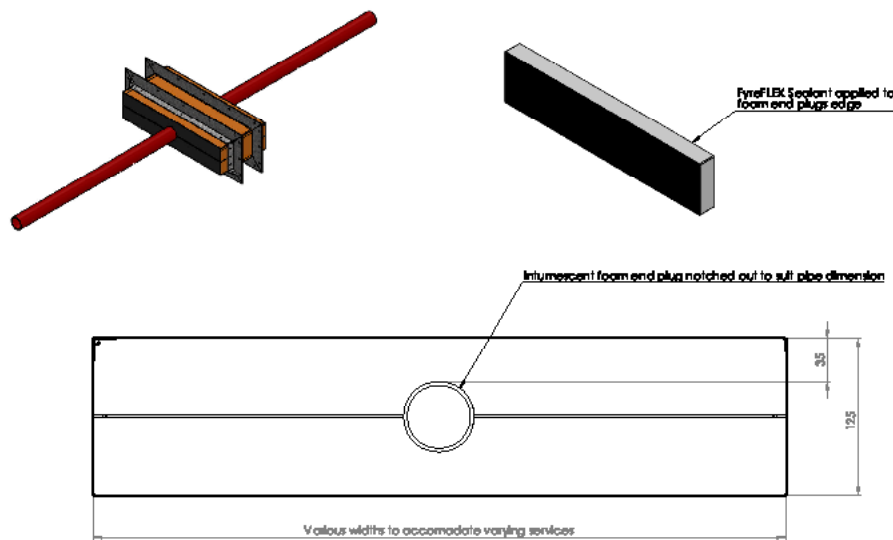

Results from the Preliminary Seismic Trials

- All conducted using the Same Trafalgar SuperSTOPPER Specimen

Slow acceleration 0.5Hz – 30 cycle per minute

- 20mm right and 20mm left (overall displacement of 40mm) – looked fine
- 20mm up and down – again looked fine
- 20mm out of plane – again looked fine

Repeat at 30 and then 50mm – No significant change except in up and down as pipe was hitting on top and bottom of SuperSTOPPER body as the internal dimension of model tested on has 125mm clearance and with a pipe of 50mm this only allow for 30mm nominal movement before interference. This caused some minor cracking or tearing of the foam.

We were happy with the preliminary trial results and this gave us the confidence to push the envelope and go for broke on a new identical specimen with serious simulated seismic activity and to have the results formally reported, for us to publish.

Trafalgar Shake Table Testing at Holmes Solutions

Stage One Formal Test Program

The following testing variables were used in the stage one formal test program:

Displacement Amplitude:

50mm (100mm total)

Movement directions:

X Axis- out of plane movement (In and Out)

Y- side to side movement

Z- up and down movement

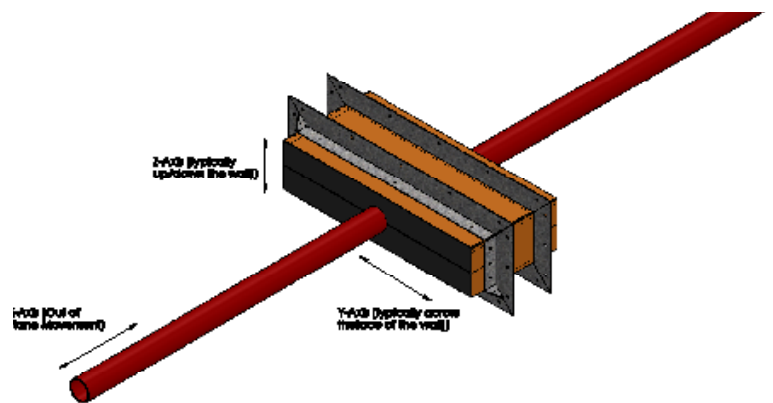

Frequency or acceleration:

Frequency of 2.5 Hz (1 Cycle every 0.4s)

Acceleration Amplitude of 1.26g

Velocity Amplitude of 785mm/s

In the absence of any pre-established performance criteria we developed several key variables to measure the performance of the SuperSTOPPER penetration system. For the SuperSTOPPER to function in fire conditions after a seismic event:

- The foam inserts must not be ripped out of the box – **PASS**
- There must not be any large through gaps through the foam inserts – some tearing was evident, but no daylight could be seen through the penetration – **PASS**
- The SuperSTOPPER metallic housing and flanges must not be damaged – **PASS**
- The SuperSTOPPER internal intumescent strips must not be damaged – **PASS**

To watch footage of the Seismic Test at Holmes Solution click here  or paste the URL in your browser:

<https://youtu.be/4RG4L00Vuho>

Trafalgar Shake Table Testing at Holmes Solutions

So, what is next? Stage Two, Three et al

The mind boggles.

This Stage One test program was just a start of our seismic testing journey.

We know it is far from definitive but we have not been able to find any firestop materials that have been seismic tested with 50mm movement, so we thought we might be leading the world with this research.

Conclusions and Thoughts Post Stage One of Seismic Testing

We need to validate a whole system, that being, services in a wall or preferably a whole room enclosure with all of our Trafalgar fire stopping systems installed.

We are comfortable that the mounting flanges for the SuperSTOPPER Maxi system will spread the load and secure the box adequately in a wall and the overall results should be similar to those observed in the stage one seismic testing.

Probably the biggest concern for an overall system is the wall to concrete slab interface. Our research suggests that current fire rated wall constructions can provide no more than 5 to 10mm of out of plane movement without serious damage to the wall itself. There are some new innovative and patented Australian designed head of wall systems that have showed outstanding results in full scale seismic testing, which may help solve this problem

It would be nice to do triaxial testing; that this movement simultaneously in the X,Y & Z orientations, but the out of plane results and the nature of the compressible foam end plug inserts suggest to us we will see nothing different to the Stage One uniaxial seismic testing we have already performed.

We need to do some different service types, perhaps a cable tray and cables, but again we are confident this will do well too.

Fire testing post seismic testing, just ticks a box, pardon the pun, as we know having looked at the Stage One Seismic minor damage to the Trafalgar SuperSTOPPER, that any post seismic fire test would be successful.

Trafalgar Shake Table Testing at Holmes Solutions